

■ AC Power  
For Business-Critical Continuity™

# Liebert® NXL™ Maintenance Bypass Cabinet

Installation Manual – 250-500kVA, 60Hz



---

## CONTACTING EMERSON NETWORK POWER<sup>®</sup> FOR SUPPORT

---

To contact Emerson Network Power Liebert<sup>®</sup> Services for information or repair service in the United States, call 1-800-LIEBERT (1-800-543-2378). Liebert Services offers a complete range of start-up services, repair services, preventive maintenance plans and service contracts.

For repair or maintenance service outside the 48 contiguous United States, contact Liebert Services, if available in your area. For areas not covered by Liebert Services, the authorized distributor is responsible for providing qualified, factory-authorized service.

For Liebert Services to assist you promptly, have the following information available:

Part Numbers: \_\_\_\_\_

Serial Numbers: \_\_\_\_\_

kVA Rating: \_\_\_\_\_

Date Purchased: \_\_\_\_\_

Date Installed: \_\_\_\_\_

Location: \_\_\_\_\_

Input Voltage/Frequency: \_\_\_\_\_

Output Voltage/Frequency: \_\_\_\_\_

### Product Warranty Registration

To register for warranty protection, visit the **Service and Support** section of our Web site at:

[www.liebert.com](http://www.liebert.com)

Click on **Product Registration** and fill out the form.

---

---

# TABLE OF CONTENTS

<b>IMPORTANT SAFETY INSTRUCTIONS</b> .....	<b>1</b>
<b>1.0 SINGLE-MODULE MECHANICAL INSTALLATION</b> .....	<b>3</b>
1.1 Introduction .....	3
1.2 Preliminary Checks .....	3
1.3 Environmental Considerations .....	4
1.3.1 Room .....	4
1.3.2 Storage .....	4
1.4 Positioning .....	4
1.4.1 Moving the Cabinets .....	4
1.4.2 Clearances .....	5
1.4.3 Floor Installation/Anchoring .....	5
1.5 Cable Entry .....	5
1.6 Power Cables .....	5
1.6.1 Power Cable Connection Procedure .....	6
<b>2.0 INSTALLATION DRAWINGS</b> .....	<b>8</b>
<b>3.0 SPECIFICATIONS</b> .....	<b>23</b>

## FIGURES

Figure 1 Cabinet arrangement—Liebert NXL UPS, battery cabinets, Maintenance Bypass Cabinet .....	6
Figure 2 Liebert NXL two-breaker Maintenance Bypass Cabinet, two-input to UPS dual input, attached .....	8
Figure 3 Liebert NXL two-breaker Maintenance Bypass Cabinet, three-input, attached .....	9
Figure 4 Liebert NXL two-breaker Maintenance Bypass Cabinet—250 and 300kVA main component location .....	10
Figure 5 Liebert NXL two-breaker Maintenance Bypass Cabinet—400kVA and 500kVA main component location .....	11
Figure 6 Liebert NXL two-breaker Maintenance Bypass Cabinet—250 and 300kVA outline drawing .....	12
Figure 7 Liebert NXL two-breaker Maintenance Bypass Cabinet—400kVA and 500kVA outline drawing .....	13
Figure 8 Liebert NXL two-breaker Maintenance Bypass Cabinet—250 and 300kVA terminal details .....	14
Figure 9 Liebert NXL two-breaker Maintenance Bypass Cabinet—400kVA and 500kVA terminal details .....	15
Figure 10 Cable routing—Two-breaker style .....	16
Figure 11 Liebert NXL two-breaker Maintenance Bypass Cabinet, point-to-point wiring to UPS .....	17
Figure 12 Liebert NXL two-breaker Maintenance Bypass Cabinet control wiring diagram without interlock .....	19
Figure 13 Liebert NXL two-breaker Maintenance Bypass Cabinet control wire diagram with interlock .....	20
Figure 14 Liebert NXL two-breaker Maintenance Bypass Cabinet control wire routing .....	21
Figure 15 Ground strap location for connected cabinets .....	22

---

## TABLES

Table 1	Emerson-supplied interconnect wiring for Liebert NXL two-breaker Maintenance Bypass Cabinet. . . . .	18
Table 2	Two-breaker control wiring connections without interlock . . . . .	19
Table 3	Two-breaker control wiring connections with interlock . . . . .	20
Table 4	Liebert NXL Maintenance Bypass Cabinet specifications . . . . .	23
Table 5	Liebert NXL Maintenance Bypass Cabinet current ratings—System Output . . . . .	24
Table 6	Recommended conduit and cable sizes—Maintenance Bypass Input . . . . .	24
Table 7	Recommended conduit and cable sizes—Rectifier input (one-input system) . . . . .	24
Table 8	Recommended conduit and cable sizes—Module Bypass Input . . . . .	24
Table 9	Liebert NXL Maintenance Bypass Cabinet current ratings—System Input . . . . .	24
Table 10	Recommended conduit and cable sizes—Module Output . . . . .	25
Table 11	Recommended conduit and cable sizes—Load Output . . . . .	25
Table 12	Recommended conduit and cable sizes—Load Bank Output . . . . .	25
Table 13	Recommended lug sizes . . . . .	26

---

## IMPORTANT SAFETY INSTRUCTIONS

---

### SAVE THESE INSTRUCTIONS

This manual contains important instructions that should be followed during installation of your Liebert NXL Maintenance Bypass Cabinet.



#### WARNING

Risk of moving heavy units and tipping hazard. Can cause equipment damage, injury and death.

Exercise extreme care when handling cabinets to avoid equipment damage or injury to personnel. The Liebert NXL Maintenance Bypass Cabinet weighs up to 755 lb (342.5kg).

Locate center of gravity symbols  and determine unit weight before handling each cabinet. Test lift and balance the cabinets before transporting. Maintain minimum tilt from vertical at all times.

Slots at the base of the cabinets are intended for forklift use. Base slots will support the unit only if the forks are completely beneath the unit.

In case of fire involving electrical equipment, use only carbon dioxide fire extinguishers or those approved for use in fighting electrical fires.

Extreme caution is required when performing maintenance.

Be constantly aware that the system contains high DC as well as AC voltages.

Check for voltage with both AC and DC voltmeters prior to making contact.

Read this manual thoroughly before working with the Maintenance Bypass Cabinet. Retain this manual for use by installing personnel.



#### WARNING

Risk of arc flash and electric shock. Can cause equipment damage, injury and death.

Under typical operation and with all doors closed, only normal safety precautions are necessary. The area around the system should be kept free of puddles of water, excess moisture and debris.

Special safety precautions are required for procedures involving handling, installation and maintenance of the Maintenance Bypass Cabinet. Observe all safety precautions in this manual before handling or installing the Maintenance Bypass Cabinet. Observe all precautions in the Operation and Maintenance Manual, before as well as during performance of all maintenance procedures.

This equipment contains circuits that are energized with high voltage. Only test equipment designed for troubleshooting should be used. This is particularly true for oscilloscopes. Always check with an AC and DC voltmeter to ensure safety before making contact or using tools.

Even when the power is turned Off, dangerously high potential electric charges may exist.

All power and control wiring should be installed by a qualified electrician. All power and control wiring must comply with the NEC and applicable local codes.

ONLY properly trained and qualified personnel should perform maintenance on the Maintenance Bypass Cabinet. When performing maintenance with any part of the equipment under power, service personnel and test equipment should be standing on rubber mats. The service personnel should wear insulating shoes for isolation from direct contact with the floor ground.

One person should never work alone, even if all power is removed from the equipment. A second person should be standing by to assist and summon help in case of an accident.

**ELECTROMAGNETIC COMPATIBILITY**—The Liebert NXL complies with the limits for a Class A Digital Device, pursuant to Part 15 Subpart J of FCC rules. Operation is subject to the following two conditions:

- This device may not cause harmful interference, and
- This device must accept any interference received, including interference that may cause undesired operation.

Operating this device in a residential area is likely to cause harmful interference that users must correct at their own expense.

The Liebert NXL complies with the requirements of EMC Directive 2004/108/EC and the published technical standards. Continued compliance requires installation in accordance with these instructions and use of accessories approved by Emerson®.



**NOTE**

*Materials sold hereunder cannot be used in the patient vicinity (e.g., use where UL, cUL or IEC 60601-1 is required). Medical applications such as invasive procedures and electrical life support equipment are subject to additional terms and conditions.*

---

## 1.0 SINGLE-MODULE MECHANICAL INSTALLATION

---

### 1.1 Introduction

This section describes the requirements that must be taken into account when planning the positioning and cabling of the Liebert NXL Maintenance Bypass Cabinet.

This chapter is a guide to general procedures and practices that should be observed by the installing engineer. The particular conditions of each site will determine the applicability of such procedures.



### WARNING

Risk of arc flash and electric shock. Can cause equipment damage, injury and death.

Installation must be performed only by properly trained and qualified personnel wearing appropriate safety clothing.

Eye protection should be worn to prevent injury from accidental electrical arcs. Remove rings, watches and all other metal objects. Only use tools with insulated handles. Wear rubber gloves.

### NOTICE

Risk of improper installation. Can cause equipment damage and void warranty.

The Maintenance Bypass Cabinet should be installed by a qualified engineer in accordance with the information contained in this chapter

All equipment not referred to in this manual is shipped with details of its own mechanical and electrical installation.

Do not apply electrical power to the UPS equipment before the arrival of the commissioning engineer.

### NOTICE

Three-phase input supply required.

The standard Liebert NXL UPS is suitable for connection to three-phase, four-wire (+ Earth) TN-C, TN-S, IT-G, IT-IG or, three-phase, three-wire plus ground, IT-UG.

If using with IT Power system, a 4-pole disconnect device must be included as part of building installation.

### 1.2 Preliminary Checks

Before installing the Maintenance Bypass Cabinet, carry out the following preliminary checks:

- Visually examine the equipment for transit damage, both internally and externally. Report any damage to the shipper immediately.
- Verify that the correct equipment is being installed. The equipment supplied has an identification tag on the back of the main door reporting: the type, size and main calibration parameters of the UPS.
- Verify that the room satisfies the environmental conditions stipulated in the equipment specifications, paying particular attention to the ambient temperature and air exchange system.

## 1.3 Environmental Considerations

### 1.3.1 Room

The Maintenance Bypass Cabinet is intended for indoor installation and should be located in a cool, dry, clean-air environment with adequate ventilation to keep the ambient temperature within the specified operating range (see **3.0 - Specifications**).

All models of the Liebert NXL Maintenance Bypass Cabinet are convection-cooled. To permit air to enter and exit and prevent overheating or malfunctioning, do not cover the ventilation openings.

When bottom entry is used, the conduit plate can be removed and punched and replaced. The bottom conduit plate must be replaced for proper airflow. If necessary to cool the room, install a system of room extractor fans.



#### NOTE

*The Maintenance Bypass Cabinet is suitable for mounting on concrete or other non-combustible surface only.*

### 1.3.2 Storage

Should the equipment not be installed immediately, it must be stored in a room for protection against excessive humidity and or heat sources (see **Table 4**).

## 1.4 Positioning

The cabinet is structurally designed to handle lifting from the base.

Access to the power terminals, auxiliary terminals blocks and power switches is from the front.

The top and front removable panels are secured to the chassis by screws. The door can be opened to give access to the power connections bars, auxiliary terminal blocks and power isolators. Front door can be opened at 180° for better Service and more flexibility in installations.

### 1.4.1 Moving the Cabinets

The route to be travelled between the point of arrival and the unit's position must be planned to make sure that all passages are wide enough for the unit and that floors are capable of supporting its weight (for instance, check that doorways, lifts, ramps, etc. are adequate and that there are no impassable corners or changes in the level of corridors).

Ensure that the cabinet weight is within the designated surface weight loading ( $\text{kg/cm}^2$ ) of any handling equipment. See **Table 4** for weight.

Ensure that any lifting equipment used in moving the cabinet has sufficient lifting capacity.

The Maintenance Bypass Cabinet can be handled by means of a fork lift or similar equipment. For operations with a fork lift, refer to installation drawings in **2.0 - Installation Drawings**.

Because the weight distribution in the cabinet is uneven, use extreme care during handling and transporting.

When moving the unit by forklift, care must be taken to protect the panels. Do not exceed a 15-degree tilt with the forklift. Bottom structure will support the unit only if the forks are completely beneath the unit.



Handling the unit with straps is not authorized.



## WARNING

Risk of moving heavy units and tipping hazard. Can cause equipment damage, injury and death.

Exercise extreme care when handling cabinets to avoid equipment damage or injury to personnel. The Liebert NXL Maintenance Bypass Cabinet weighs up to 755 lb (342.5kg).

Locate center of gravity symbols  and determine unit weight before handling each cabinet. Test lift and balance the cabinets before transporting. Maintain minimum tilt from vertical at all times.

Slots at the base of the cabinets are intended for forklift use. Base slots will support the unit only if the forks are completely beneath the unit.

### 1.4.2 Clearances

Liebert NXL Maintenance Bypass Cabinets have no ventilation grilles at either side or at the rear. Clearance around the front of the equipment should be sufficient to enable free passage of personnel with the doors fully opened. It is important to leave a distance of 24" (610mm) between the top of the cabinet and any overhead obstacles to permit adequate circulation of air coming out of the unit.

### 1.4.3 Floor Installation/Anchoring

The installation diagrams in **2.0 - Installation Drawings** of this manual identify the location of the holes in the base plate through which the equipment can be bolted to the floor. If the equipment is to be located on a raised floor it should be mounted on a pedestal suitably designed to accept the equipment point loading. Refer to the base view to design this pedestal.

## 1.5 Cable Entry

Cables can enter the Maintenance Bypass Cabinet from the bottom or top.

## 1.6 Power Cables

The Maintenance Bypass Cabinet requires both power and control cabling once it has been mechanically installed. All control cables must be separate from the power cables. Run control cables in metal conduits or metal ducts that are electrically bonded to the cabinets they are connected to.

The cable design must comply with the voltages and currents provided in **Tables 8 through 13**, follow local wiring practices and take into consideration the environmental conditions (temperature and physical support media).

For cable entry terminal, refer to **Figure 8**.



## WARNING

Risk of electric shock. Can cause equipment damage, injury and death.

Before cabling up the cabinet, ensure that you are aware of the location and operation of the external isolators that connect the input/bypass supply.

Check that these supplies are electrically isolated, and post any necessary warning signs to prevent their inadvertent operation.

The following are guidelines only and superseded by local regulations and codes of practice where applicable:

- Take special care when determining the size of the neutral cable (grounded conductor), because current circulating on the neutral cable may be greater than nominal current in the case of non-linear loads. Refer to **Tables 8 through 13**.
- The grounding conductor should be sized according to the fault rating, cable lengths, type of protection, etc. The grounding cable connecting the UPS to the main ground system must follow the most direct route possible.
- Consider using smaller, paralleled cables for heavy currents as a way of easing installation.

Figure 1 Cabinet arrangement—Liebert NXL UPS, battery cabinets, Maintenance Bypass Cabinet

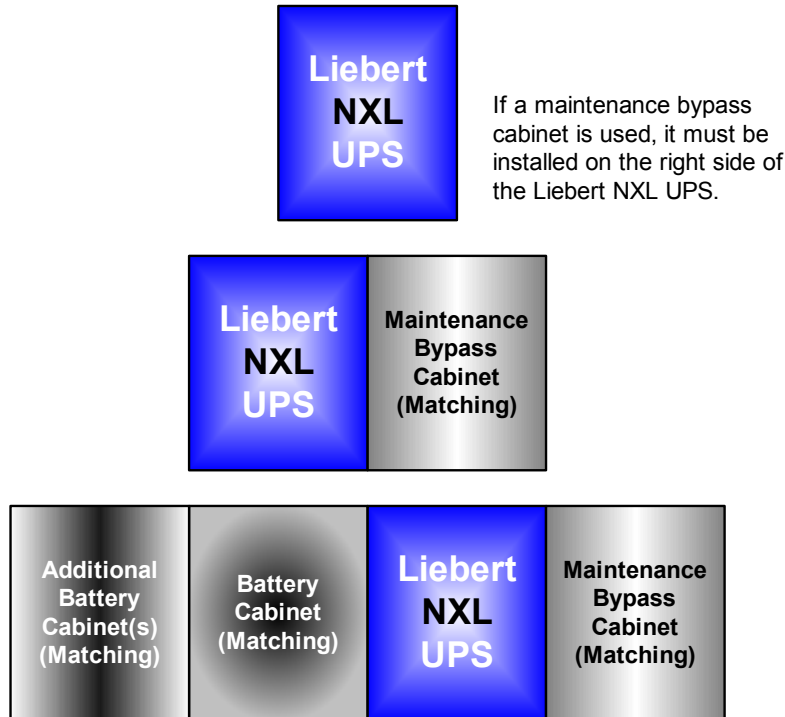

### 1.6.1 Power Cable Connection Procedure

The system input, UPS bypass, UPS output and system output cables (all require lug type terminations) are connected to busbars situated behind the power isolator switches as shown in **2.0 - Installation Drawings**. These are accessible when the power compartment door is opened.

#### Equipment Ground

The equipment ground busbar is located near the input and output power supply connections as shown in **2.0 - Installation Drawings**. The grounding conductor must be connected to the ground busbar.

All cabinets and cable trunking should be grounded in accordance with local regulations.



#### WARNING

Risk of electric shock. Can cause equipment damage, injury and death.

Failure to follow adequate grounding procedures can result in electric shock hazard to personnel and the risk of fire, should a ground fault occur.



#### WARNING

Risk of electric shock. Can cause equipment damage, injury and death.

The operations described in this section must be performed by authorized electricians or properly trained and qualified technical personnel wearing adequate safety clothing, eye protection and gloves.

If you have any difficulties, do not hesitate to contact Emerson Network Power® Liebert Services. See the back page of this manual for contact information.



#### NOTE

*Proper grounding considerably reduces problems in systems caused by electromagnetic interference.*

Once the equipment has been finally positioned and secured, connect the power cables as described in the following procedure.

Refer to the appropriate cable connection drawing in **2.0 - Installation Drawings**.

1. Verify that the bypass equipment is isolated from its external power source and all the power isolators are open. Check that these supplies are electrically isolated and post any necessary warning signs to prevent their inadvertent operation.
2. Open the door to the cabinet and remove the interior panels.
3. Connect the ground and any necessary main bonding jumper to the equipment ground busbar.

**NOTE**

*The grounding and neutral bonding arrangement must be in accordance with local and national codes of practice.*

**NOTE**

*Care must be taken when routing power cable. Ensure that cables do not touch other busbars (see **Figure 10**).*

**NOTE**

*Do not double-stack lugs: do not layer two lugs on the same side of the busbar (see **Figure 10**).*

4. Connect the AC input supply cables between the power distribution panel and the Maintenance Bypass input supply busbars (A-B-C or A-B-C-N terminals) and tighten the connections to the proper torque. Ensure correct phase rotation!
5. Connect the UPS Input
  - a. For two-breaker Maintenance Bypass Cabinets
    - i. If the system is a three-input type, connect the AC input supply cables between the power distribution panel and the UPS bypass input supply busbars (A-B-C or A-B-C-N terminals) and between the power distribution panel and the UPS rectifier input supply busbars (A-B-C or A-B-C-N terminals). Tighten the connections to the proper torque. Ensure correct phase rotation!
    - ii. If the system is a two-input type, connect the AC input supply cables between the Maintenance Bypass Cabinet and the UPS bypass input supply busbars (A-B-C or A-B-C-N terminals) and between the power distribution panel and the UPS rectifier input supply busbars (A-B-C or A-B-C-N terminals). Tighten the connections to the proper torque. Ensure correct phase rotation!
6. Connect the system output power cables between the Maintenance Bypass Cabinet output (A-B-C or A-B-C-N terminals) and the critical load and tighten the connections to the proper torque. Ensure correct phase rotation!
7. Connect the auxiliary cables of any external interface/signals to the respective connections of the output auxiliary terminal block (X4) (see **2.0 - Installation Drawings**).
8. Replace interior panels and close door.

## 2.0 INSTALLATION DRAWINGS

Figure 2 Liebert NXL two-breaker Maintenance Bypass Cabinet, two-input to UPS dual input, attached

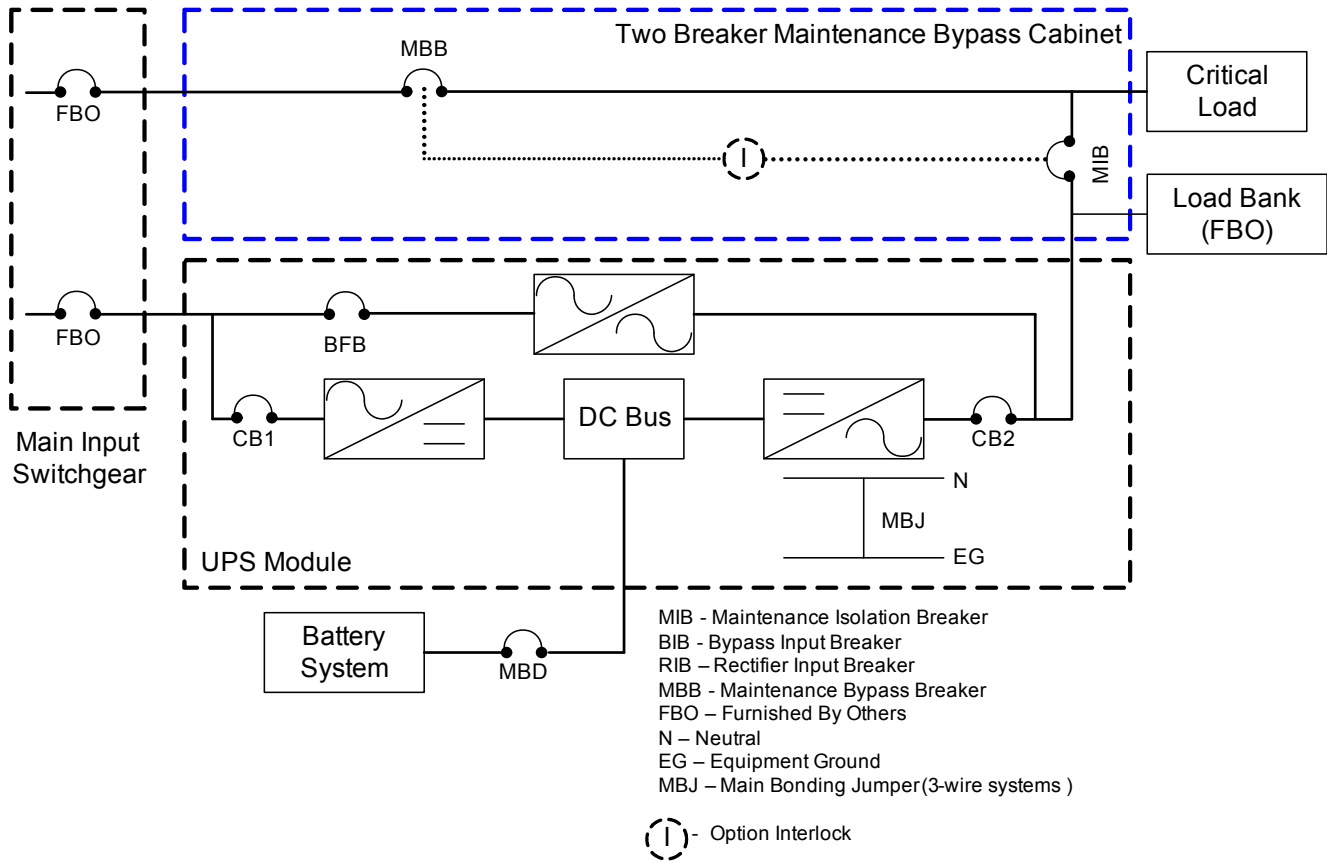

Figure 3 Liebert NXL two-breaker Maintenance Bypass Cabinet, three-input, attached

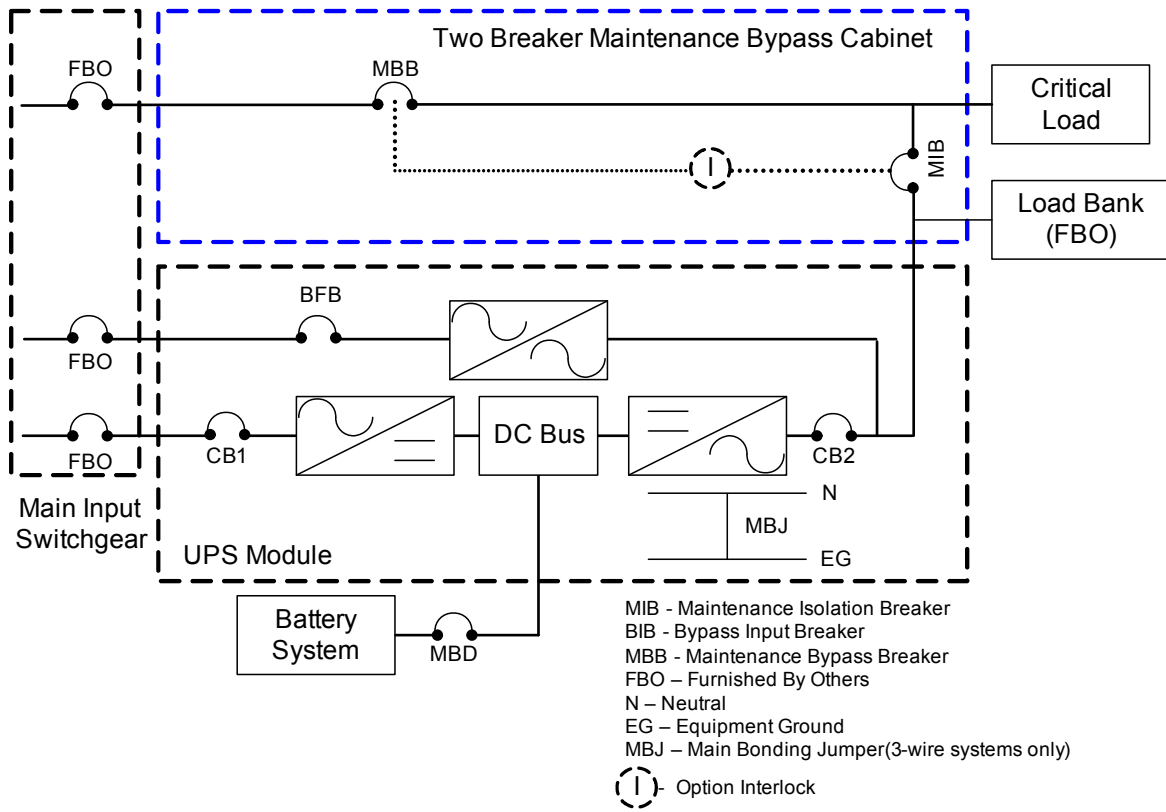

Figure 4 Liebert NXL two-breaker Maintenance Bypass Cabinet—250 and 300kVA main component location

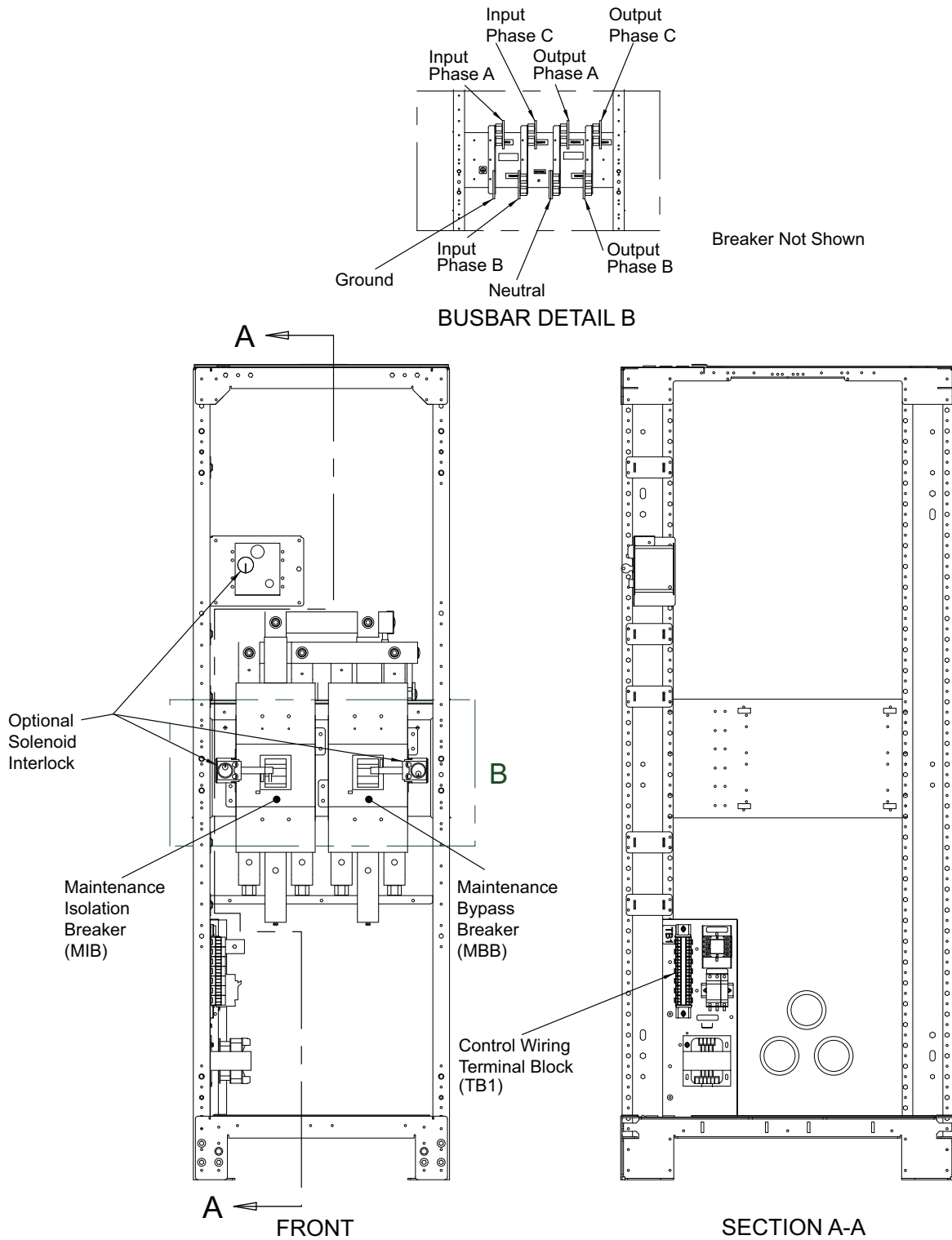
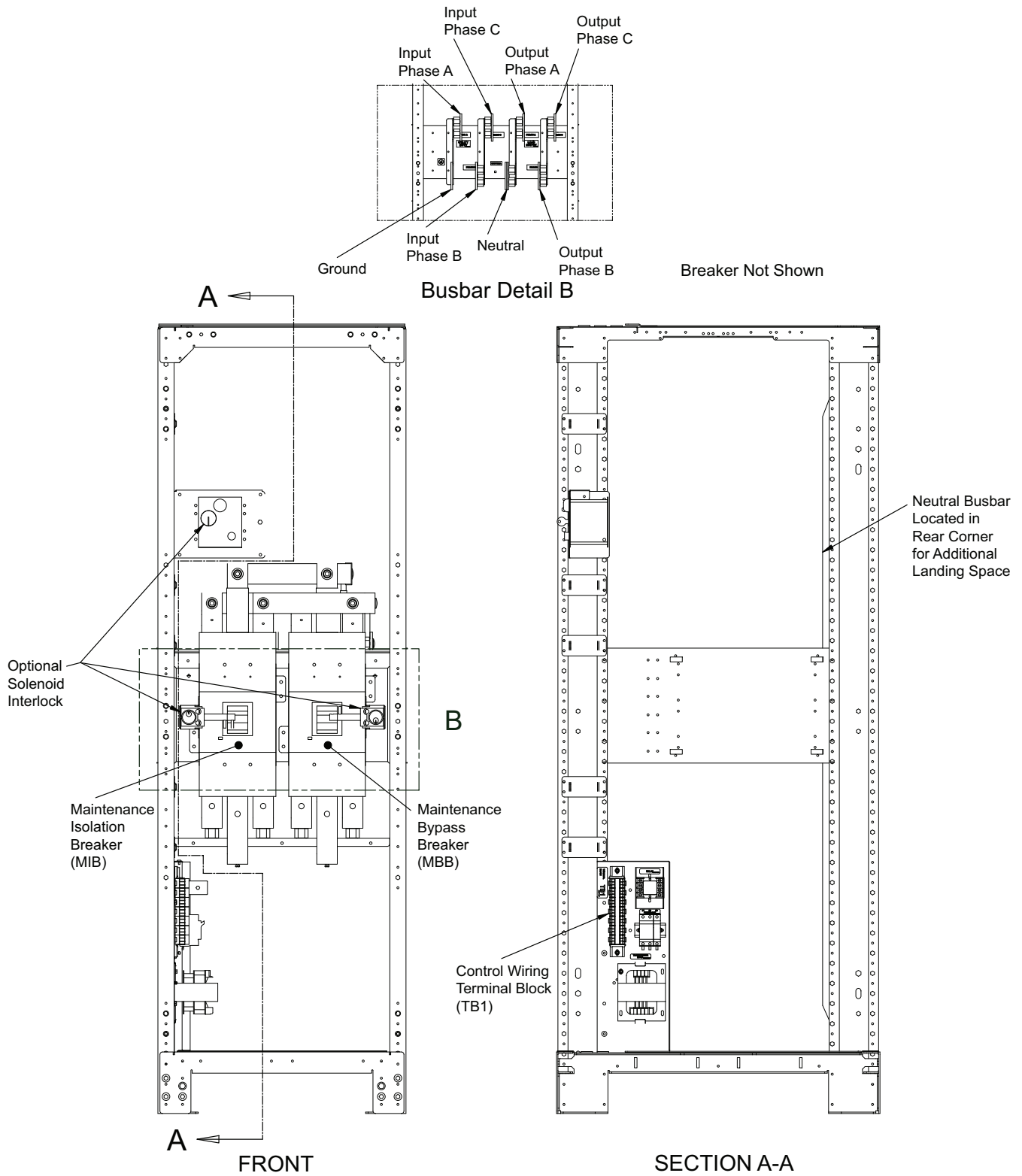
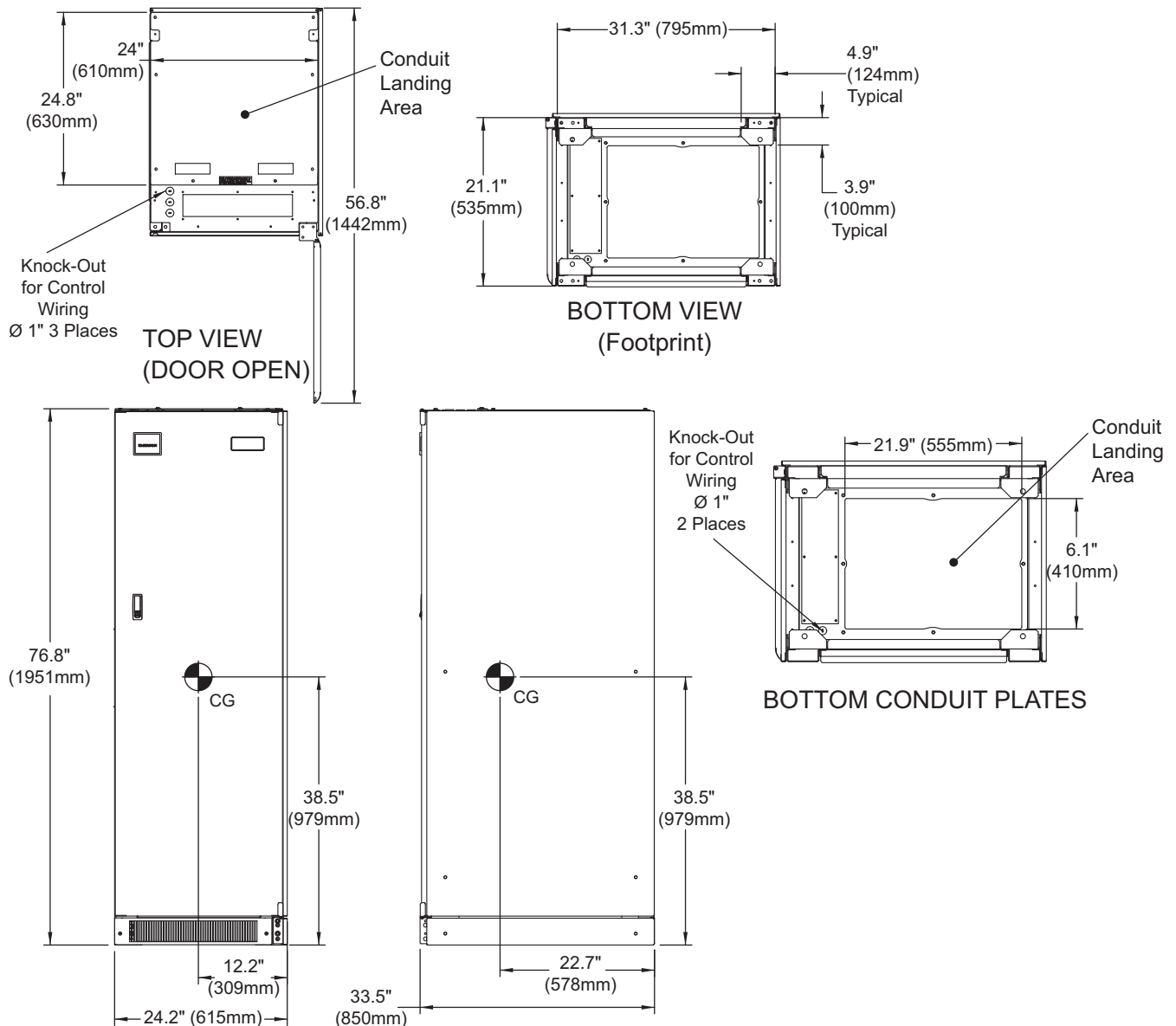

Figure 5 Liebert NXL two-breaker Maintenance Bypass Cabinet—400kVA and 500kVA main component location



**Figure 6 Liebert NXL two-breaker Maintenance Bypass Cabinet—250 and 300kVA outline drawing**



**NOTES:**

1. All dimensions are in inches (mm).
2. 24" minimum clearance above unit required for air exhaust.
3. Keep cabinet within 15 degrees of vertical while handling.
4. Top and bottom cable entry available through removable access plates.  
Remove, punch to suit conduit size and replace.
5. Unit bottom is structurally adequate for forklift handling.
6. Includes side panel. Side panels are removed between adjacent units which are bolted together.
7. Control wiring and power wiring must be run in separate conduits.
8. Unless otherwise noted, use copper or aluminum conductors suitable for at least 75°C.
9. All wiring is to be in accordance with national and local electrical codes.
10. Widths are without side panels. The width is 25.6" (650mm) with side panels.
11. The depth dimension includes the front door and rear panel.



Figure 7 Liebert NXL two-breaker Maintenance Bypass Cabinet—400kVA and 500kVA outline drawing

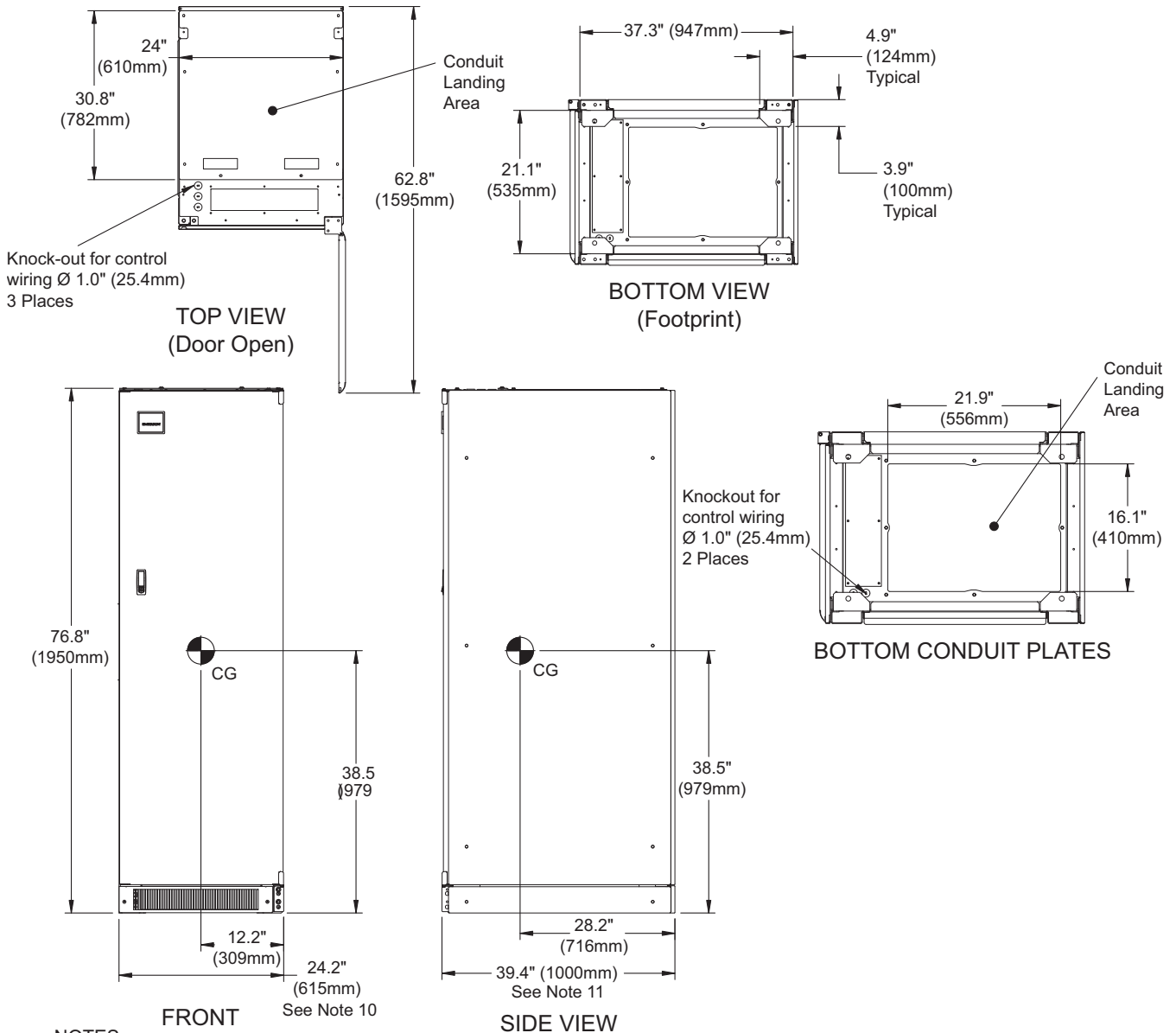

NOTES:

1. All dimensions are in inches (mm).
2. 24" minimum clearance above unit required for air exhaust.
3. Keep cabinet within 15 degrees of vertical while handling.
4. Top and bottom cable entry available through removable access plates.  
 Remove, punch to suit conduit size and replace.
5. Unit bottom is structurally adequate for forklift handling.
6. Includes side panel. Side panels are removed between adjacent units which are bolted together.
7. Control wiring and power wiring must be run in separate conduits.
8. Unless otherwise noted, use copper or aluminum conductors suitable for at least 75°C.
9. All wiring is to be in accordance with national and local electrical codes.
10. Widths are without side panels. The width is 25.6" (650mm) with side panels.
11. The depth dimension includes the front door and rear panel.

Figure 8 Liebert NXL two-breaker Maintenance Bypass Cabinet—250 and 300kVA terminal details

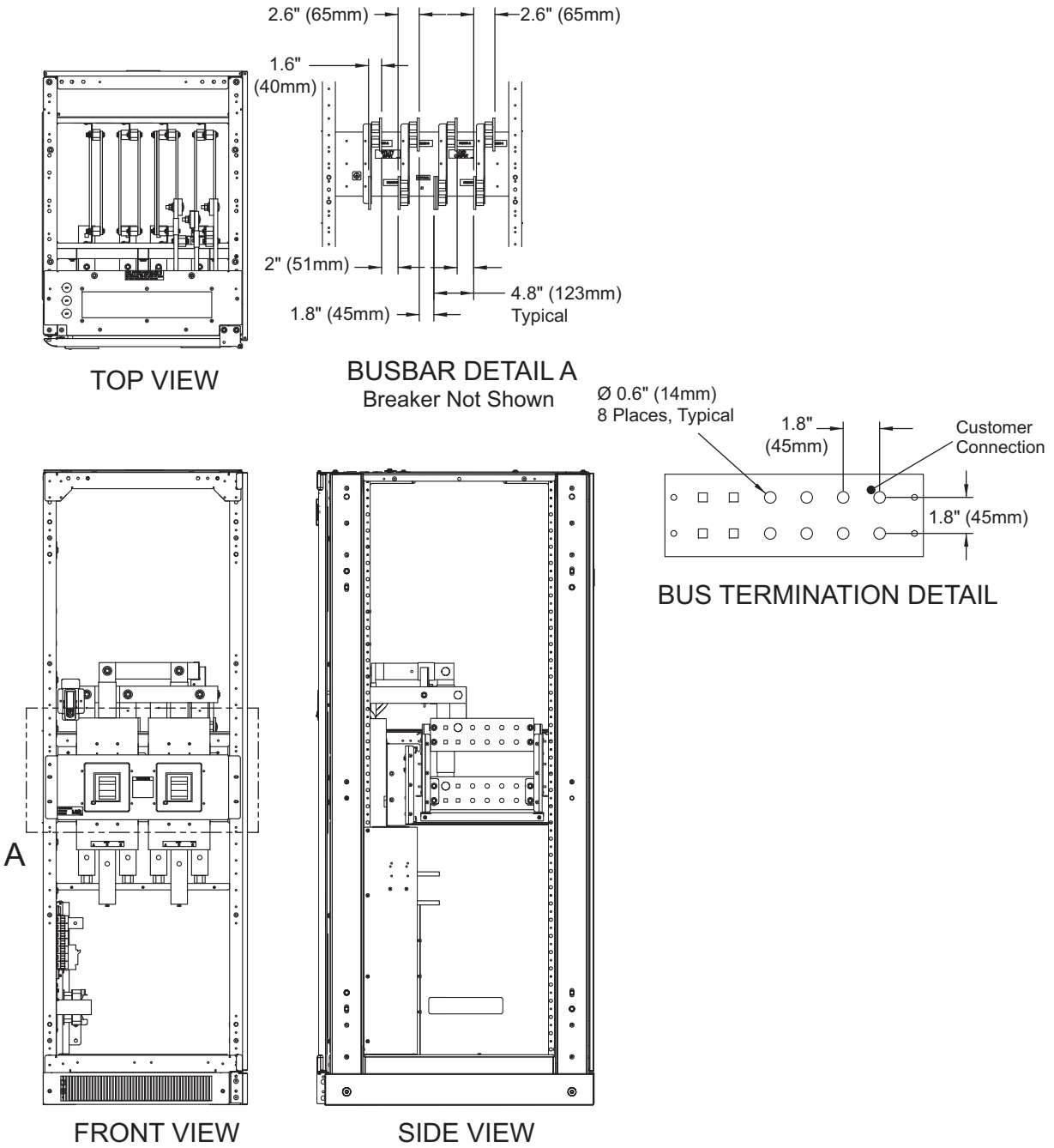

Figure 9 Liebert NXL two-breaker Maintenance Bypass Cabinet—400kVA and 500kVA terminal details

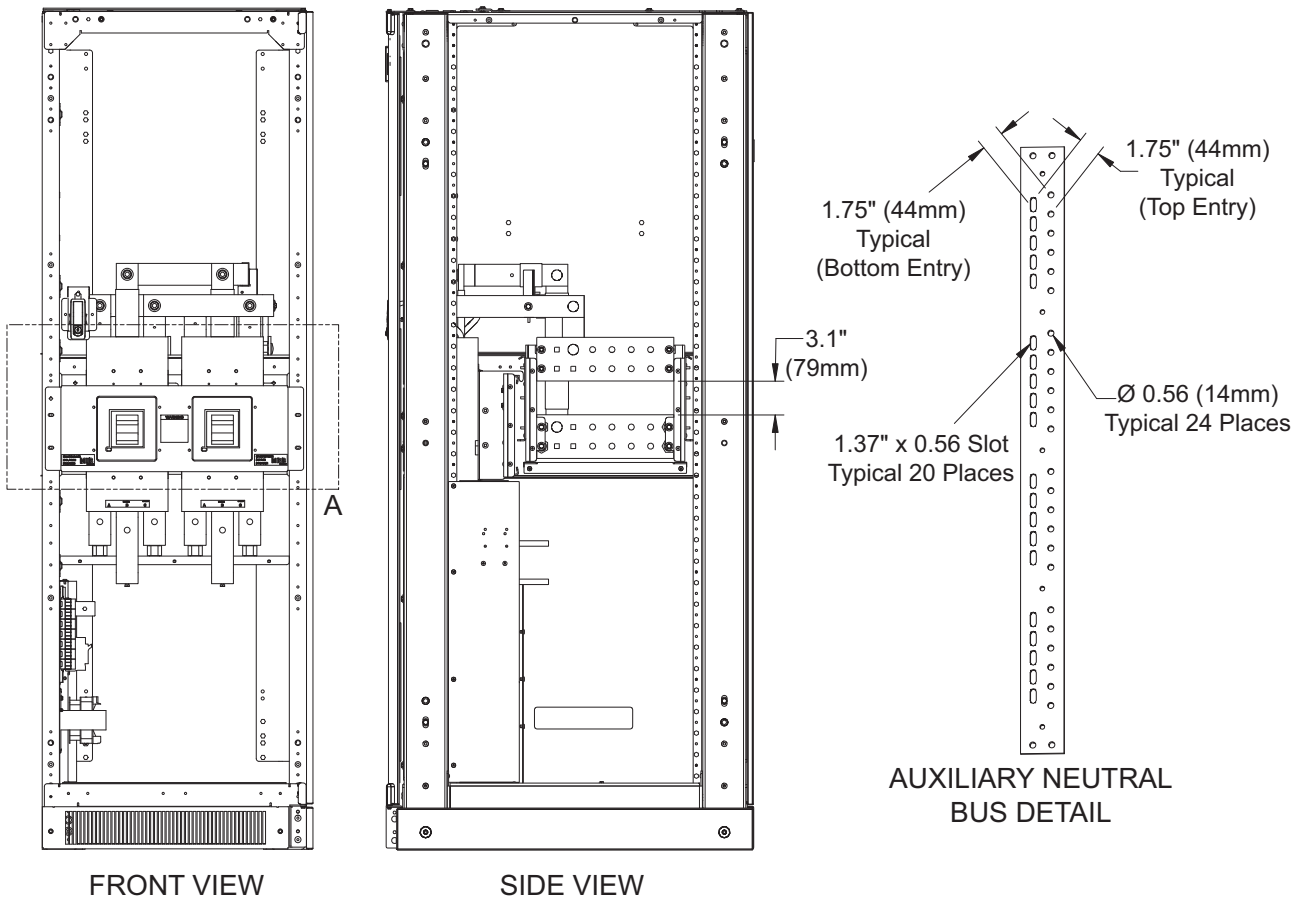
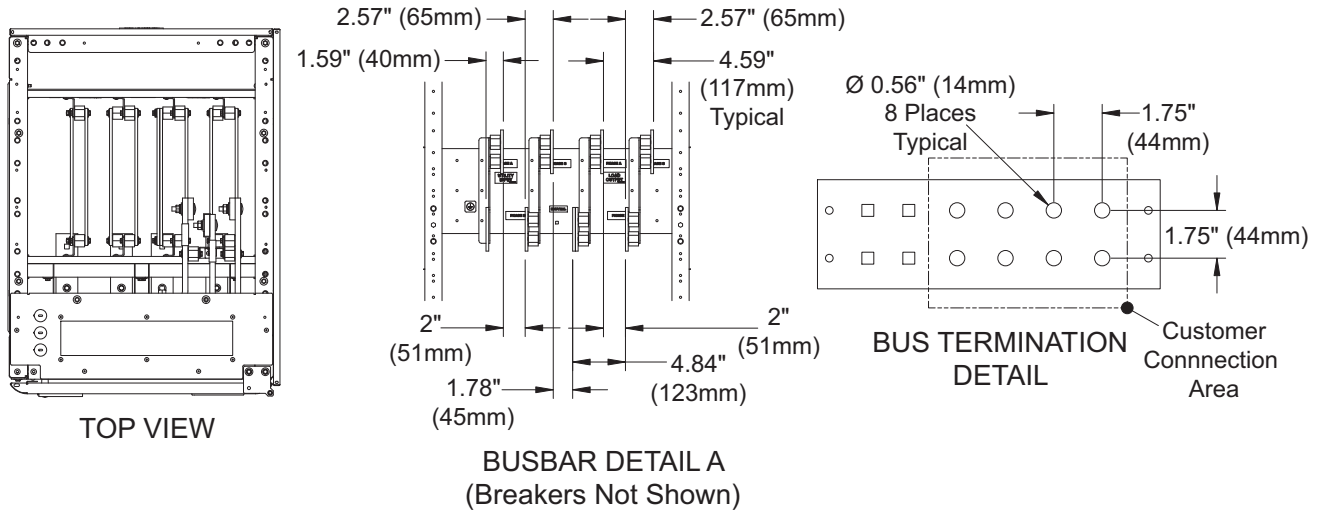
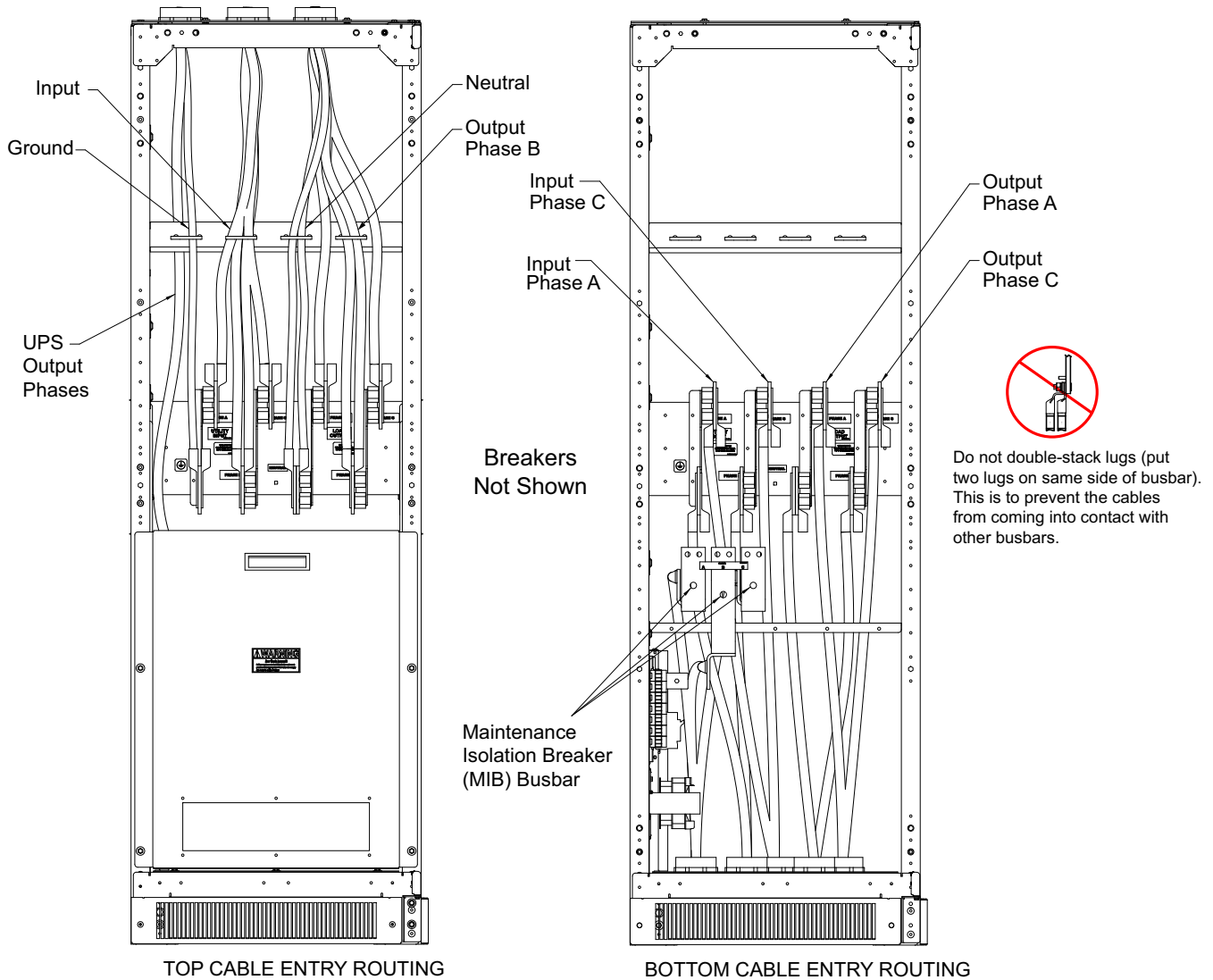

Figure 10 Cable routing—Two-breaker style



TOP ENTRY NOTES:

1. Cables from lower busbars must be routed and tied to the aligning holes on the the cable landing bar directly above (see figure below). Installation method is to prevent cables from lower busbars from contacting the upper busbars.
2. Cables from upper busbars can be optionally tied also, as shown in top entry view.
3. The UPS output phase cables must be run on the left side of cabinet, outside of the ground bus.

BOTTOM ENTRY NOTES:

1. Cables from upper busbars must be routed so that they run clear of lower busbars.

Figure 11 Liebert NXL two-breaker Maintenance Bypass Cabinet, point-to-point wiring to UPS

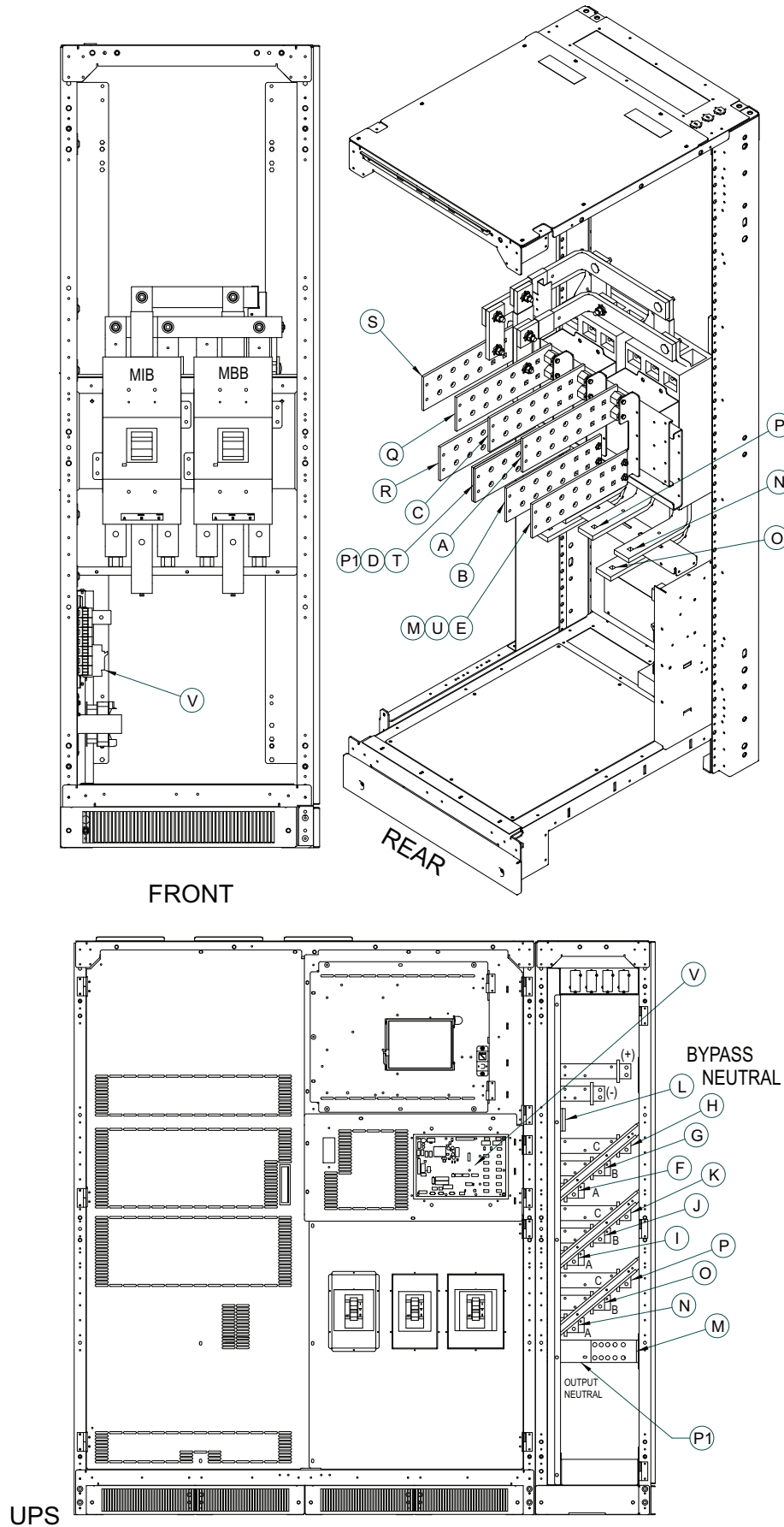

**Table 1 Emerson-supplied interconnect wiring for Liebert NXL two-breaker Maintenance Bypass Cabinet**

Run	To	From	Conductor
A	Utility AC - Phase A	MBC Bypass AC - Phase A	Maintenance Bypass AC - Phase A
B	Utility AC - Phase B	MBC Bypass AC - Phase B	Maintenance Bypass AC - Phase B
C	Utility AC - Phase C	MBC Bypass AC - Phase C	Maintenance Bypass AC - Phase C
D	Utility Neutral	MBC Neutral	System Input Neutral
E	Utility Ground	MBC Ground	System Ground
F	Utility AC - Phase A	UPS Bypass AC - Phase A	UPS Bypass Input - Phase A
G	Utility AC - Phase B	UPS Bypass AC - Phase B	UPS Bypass Input - Phase B
H	Utility AC - Phase C	UPS Bypass AC - Phase C	UPS Bypass Input - Phase C
I	Utility AC - Phase A	UPS Rectifier AC - Phase A	UPS Rectifier Input - Phase A
J	Utility AC - Phase B	UPS Rectifier AC - Phase B	UPS Rectifier Input - Phase B
K	Utility AC - Phase C	UPS Rectifier AC - Phase C	UPS Rectifier Input - Phase C
L	Utility Neutral	UPS Neutral	UPS Neutral
M*	MBC Ground	UPS Equipment Ground	UPS Ground
N	UPS Output AC - Phase A	MBC Output AC - Phase A	UPS Output - Phase A
O	UPS Output AC - Phase B	MBC Output AC - Phase B	UPS Output - Phase B
P	UPS Output AC - Phase C	MBC Output AC - Phase C	UPS Output - Phase C
P1	UPS Output Neutral	MBC Neutral	UPS Neutral
Q	MBC Output AC - Phase A	Load AC - Phase A	Load AC Input - Phase A
R	MBC Output AC - Phase B	Load AC - Phase B	Load AC Input - Phase B
S	MBC Output AC - Phase C	Load AC - Phase C	Load AC Input - Phase C
T	MBC Neutral	Load Neutral	Load Neutral
U	MBC Ground	Load Ground	Load Equipment Ground
V	MBC Terminal Strip	UPS External Interface Board	Control Wiring

\* For detached units only

Figure 12 Liebert NXL two-breaker Maintenance Bypass Cabinet control wiring diagram without interlock

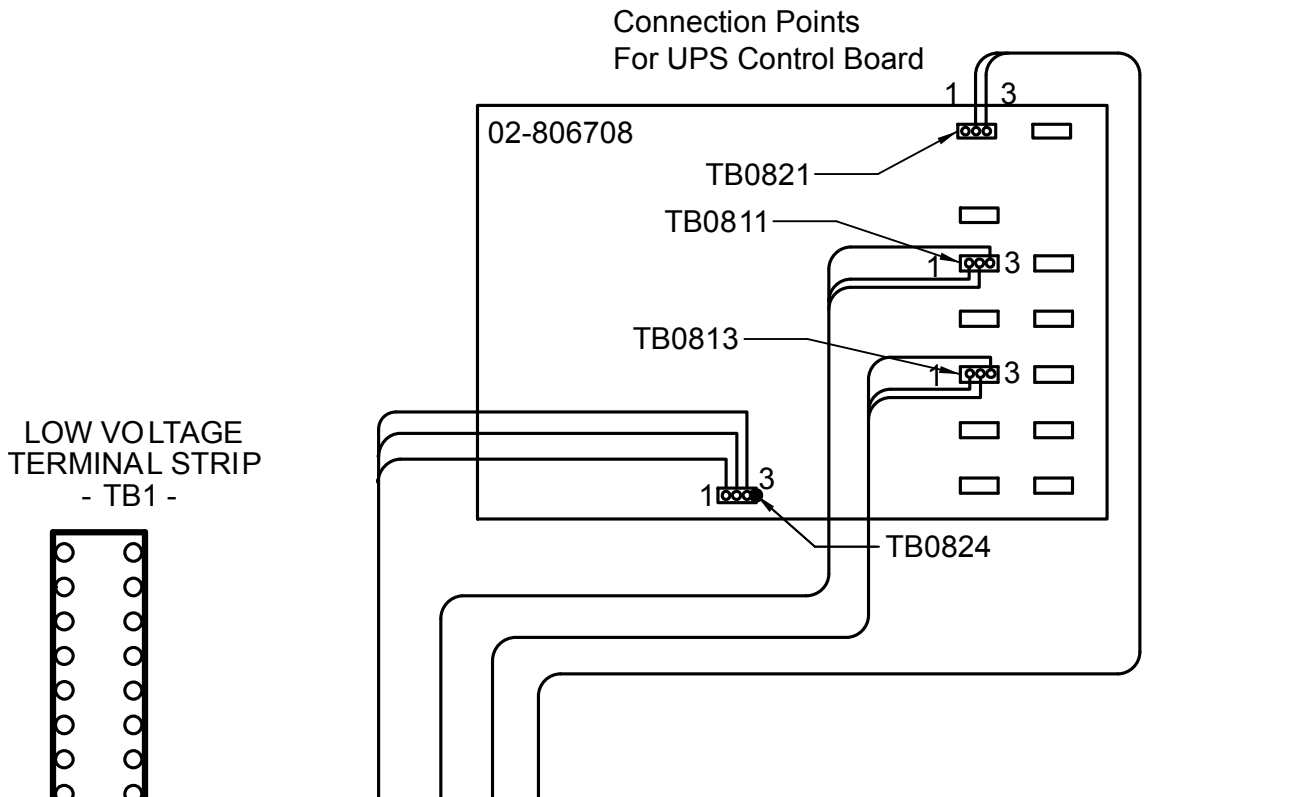

Table 2 Two-breaker control wiring connections without interlock

From	To	Purpose
TB1-1	Customer EPO Push Button Switch	EPO Signal(N.O.)
TB1-2	Customer EPO Push Button Switch	
TB1-3	TB0821-2	Maint. Bypass Enable Contacts
TB1-4	TB0821-3	
TB1-5	TB0824-3	UPS REPO Contacts (Move Jumper J5 to Pos 1&2 on the UPS EIB)
TB1-6	TB0824-2	
TB1-7	TB0824-1	
TB1-8	TB0811-3	MIB Contacts
TB1-9	TB0811-2	
TB1-10	TB0811-1	
TB1-11	TB0813-3	MBB Contacts
TB1-12	TB0813-2	
TB1-13	TB0813-1	

Figure 13 Liebert NXL two-breaker Maintenance Bypass Cabinet control wire diagram with interlock

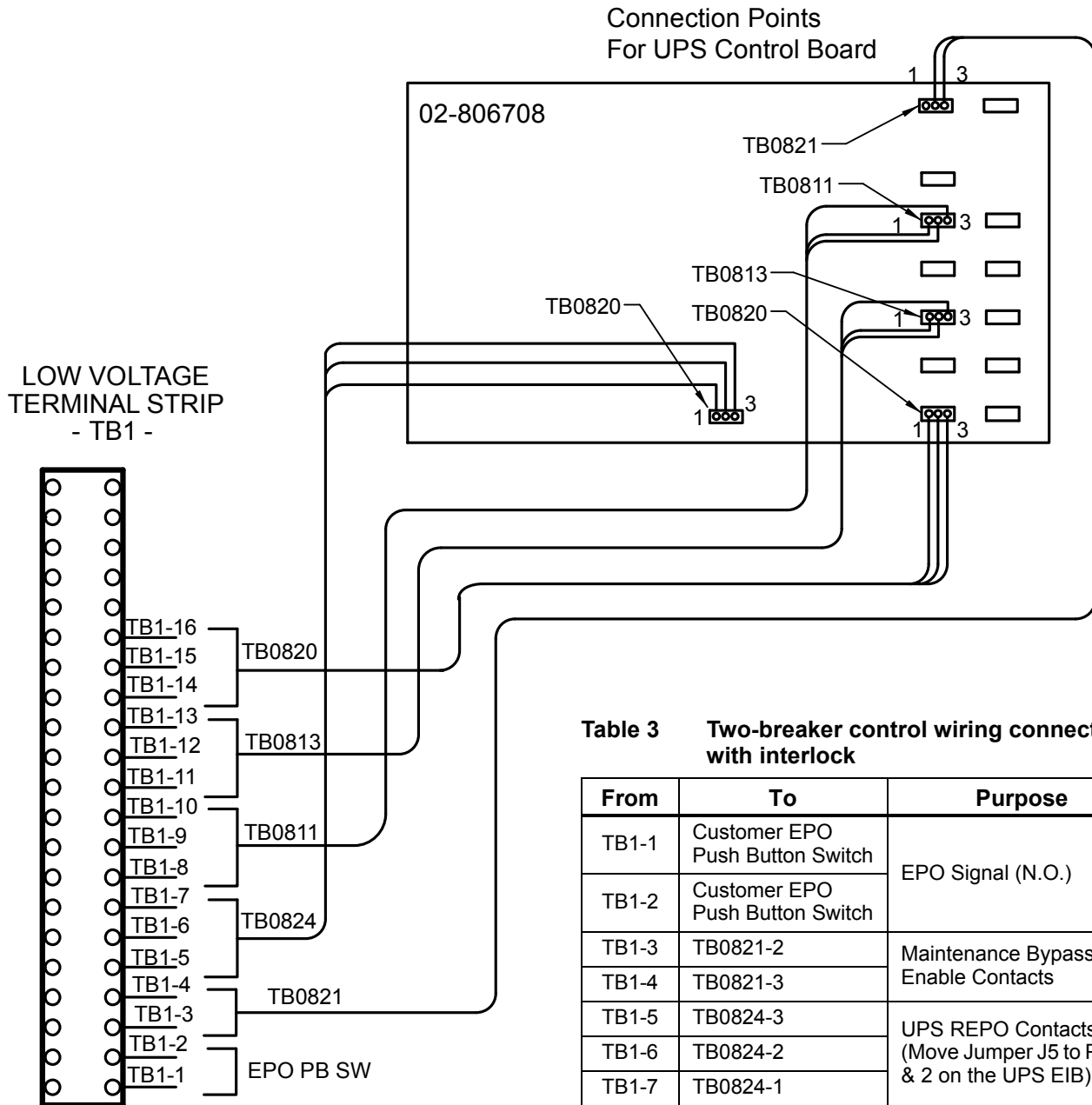

Table 3 Two-breaker control wiring connections with interlock

From	To	Purpose
TB1-1	Customer EPO Push Button Switch	EPO Signal (N.O.)
TB1-2	Customer EPO Push Button Switch	
TB1-3	TB0821-2	Maintenance Bypass Enable Contacts
TB1-4	TB0821-3	
TB1-5	TB0824-3	UPS REPO Contacts (Move Jumper J5 to Pos 1 & 2 on the UPS EIB)
TB1-6	TB0824-2	
TB1-7	TB0824-1	
TB1-8	TB0811-3	MIB Contacts
TB1-9	TB0811-2	
TB1-10	TB0811-1	MBB Contacts
TB1-11	TB0813-3	
TB1-12	TB0813-2	
TB1-13	TB0813-1	SKRU Key Status Contacts
TB1-14	TB0820-3	
TB1-15	TB0820-2	
TB1-16	TB0820-1	



Figure 14 Liebert NXL two-breaker Maintenance Bypass Cabinet control wire routing

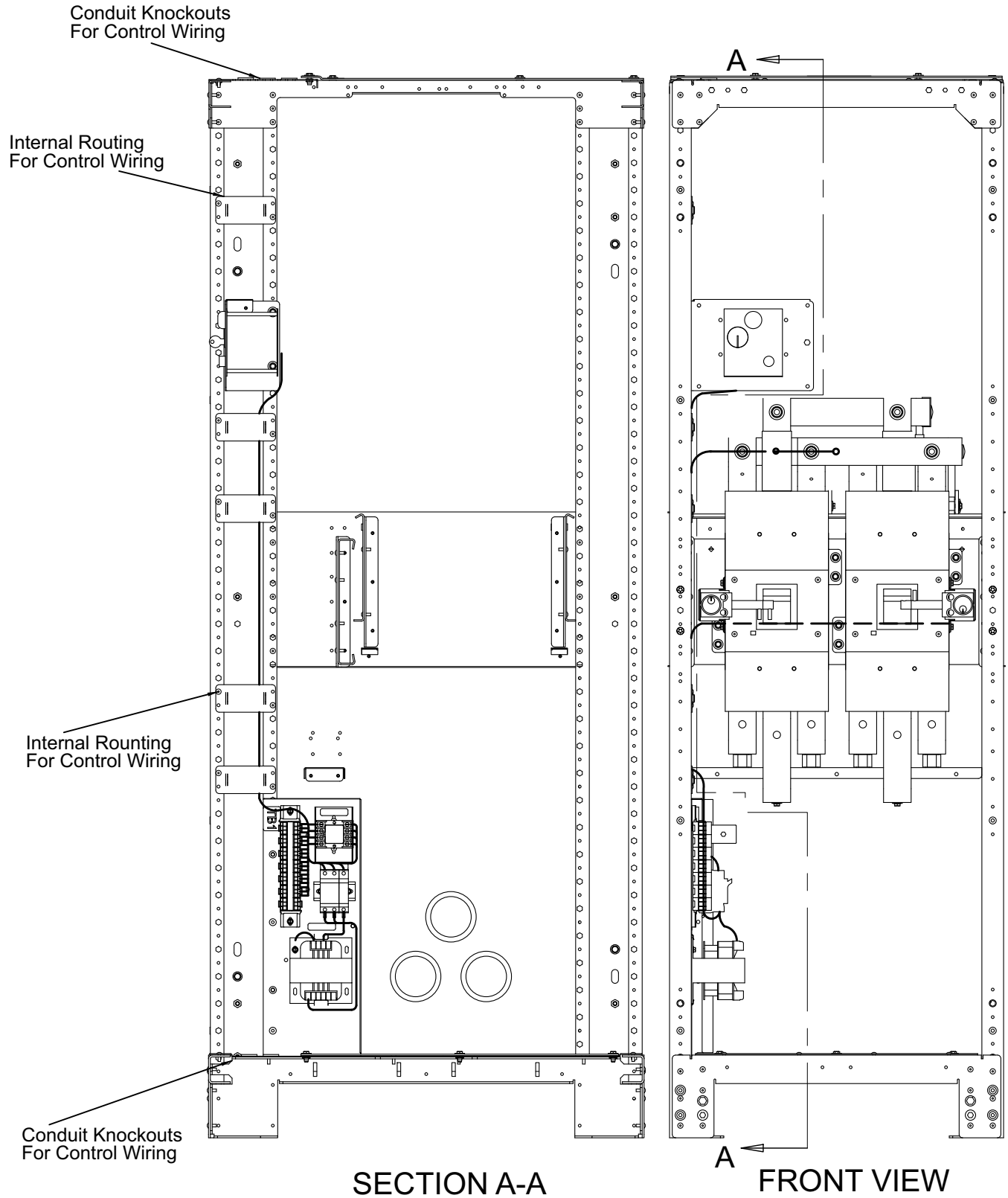
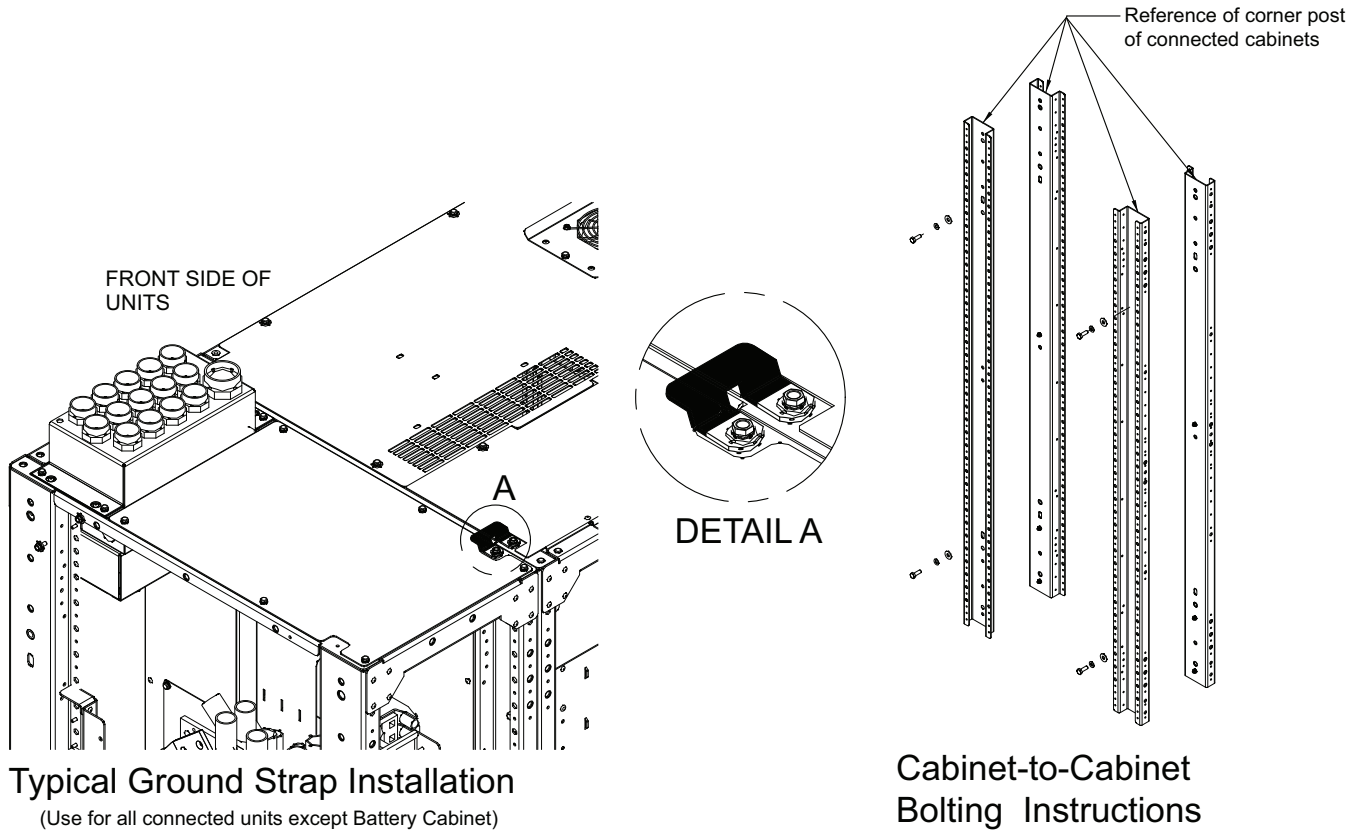

Figure 15 Ground strap location for connected cabinets



### 3.0 SPECIFICATIONS

**Table 4 Liebert NXL Maintenance Bypass Cabinet specifications**

Model Size, kVA	250	300	400	500
<b>Input Parameters</b>				
Input Voltage to Bypass, VAC	480V 3-phase, 3-wire or 4-wire			
Permissible Input Voltage Range, VAC	+10% to -30%			
Input Frequency, Hz	60			
Permissible Input Frequency Range, Hz	55 to 65			
Neutral Current	1.7 times full phase current			
<b>Output Parameters</b>				
Output Power, kW	225	270	360	450
Output Voltage, VAC	480V 3-ph, 3-wire or 4-wire			
Output Frequency, Hz	60			
<b>Physical Parameters &amp; Standards, in (mm)</b>				
Two-Breaker Width in. (mm) with side panels attached	25.6 (650)			
Depth in. (mm)	33.5 (850)		39.4 (1000)	
Height in. (mm)	76.8 (1950)			
Weight, lb (kg)	755 (342.5)			
Color	Charcoal (ZP-0420)			
Front Door Opening (for serviceability)	More than 180°			
Degree of Protection for UPS Enclosure	IP 20 (with and without front door open)			
Standards and Conformities	UL 1778; CSA 22.2 107.3; FCC Part 15, Class A ISTA Procedure 1H; WEEE; IBC 2012/CBC 2010			
Minimum clearance, Top, in (mm)	24 (610)			
Minimum clearance, Back, in (mm)	0			
Minimum clearance, Sides, in (mm)	0			
Location of cable entrance	Top or Bottom			
<b>Environmental Parameters</b>				
Storage Temperature Range, °F (°C)	-13 to 158 (-25 to 70)			
Operating Temperature Range, °F (°C)	0 to 40 (UPS)			
Relative Humidity	Maximum 95% Non-Condensing (Operating and Non-Operating)			
Maximum Altitude above MSL, ft (m)	4920 (1500) (as per IEC 62040/3) - 1% maximum kW derate / 328 rise between 4921-9843 (100 rise between 1500-3000)			

**Table 5 Liebert NXL Maintenance Bypass Cabinet current ratings—System Input**

UPS Rating		Voltage (VAC) Input, Bypass and Output	System Input	
kVA	kW		Nominal Current	Recommended External Breaker Trip, Amps
6-Pulse Plus Filter Design				
250	225	480	313	400
300	270	480	376	500
400	360	480	500	700
500	450	480	623	800

**Table 6 Liebert NXL Maintenance Bypass Cabinet current ratings—System Output**

UPS Rating		Voltage (VAC) Input, Bypass, and Output	System Output	
kVA	kW		Nominal Current	Recommended External Breaker Trip, Amps
6-Pulse Plus Filter Design				
250	225	480	301	400
300	270	480	361	500
400	360	480	481	700
500	450	480	601	800

**Table 7 Recommended conduit and cable sizes—Maintenance Bypass Input**

UPS Rating		Voltage (VAC) Input, Bypass and Output	Maintenance Bypass Input
kVA	kW		Nominal Selection (#) Conduit Size, Ph, N,G
6-Pulse Plus Filter Design			
250	225	480	(2) 3C 3-250kcmil, 2-250kcmil, #1/0AWG
300	270	480	(2) 3.5C 3-350kcmil, 2-350kcmil, #1/0AWG
400	360	480	(2) 4C 3-500kcmil, 2-500kcmil, #1/0AWG
500	450	480	(3) 3.5C 3-500kcmil, 2-250kcmil, #1/0AWG

**Table 8 Recommended conduit and cable sizes—Rectifier input (one-input system)**

UPS Rating		Voltage (VAC) Input, Bypass and Output	Rectifier Input (1 Input System)
kVA	kW		Nominal Selection (#) Conduit Size, Ph, N,G
6-Pulse Plus Filter Design			
250	225	480	(2) 2.5C 3-250kcmil, #1/0AWG
300	270	480	(2) 3C 3-350kcmil, #1/0AWG
400	360	480	(2) 3C 3-500kcmil, #1/0AWG
500	450	480	(3) 3C 3-500kcmil, #2/0AWG

**Table 9 Recommended conduit and cable sizes—Module Bypass Input**

UPS Rating		Voltage (VAC) Input, Bypass and Output	Module Bypass Input Nominal Selection (#) Conduit Size, Ph, N,G
kVA	kW		
6-Pulse Plus Filter Design			
250	225	480	(2) 3C 3-250kcmil, 2-250kcmil, #1/0AWG
300	270	480	(2) 3.5C 3-350kcmil, 2-350kcmil, #1/0AWG
400	360	480	(2) 4C 3-500kcmil, 2-500kcmil, #1/0AWG
500	450	480	(3) 3.5C 3-500kcmil, 2-250kcmil, #1/0AWG

**Table 10 Recommended conduit and cable sizes—Module Output**

UPS Rating		Voltage (VAC) Input, Bypass and Output	Module Output Nominal Selection (#) Conduit Size, Ph, N,G
kVA	kW		
6-Pulse Plus Filter Design			
250	225	480	(2) 3C 3-250kcmil, 2-250kcmil, #1/0AWG
300	270	480	(2) 3.5C 3-350kcmil, 2-350kcmil, #1/0AWG
400	360	480	(2) 4C 3-500kcmil, 2-500kcmil, #1/0AWG
500	450	480	(3) 3.5C 3-500kcmil, 2-250kcmil, #1/0AWG

**Table 11 Recommended conduit and cable sizes—Load Output**

UPS Rating		Voltage (VAC) Input, Bypass and Output	Load Output Nominal Selection (#) Conduit Size, Ph, N,G
kVA	kW		
6-Pulse Plus Filter Design			
250	225	480	(2) 3C 3-250kcmil, 2-250kcmil, #1/0AWG
300	270	480	(2) 3.5C 3-350kcmil, 2-350kcmil, #1/0AWG
400	360	480	(2) 4C 3-500kcmil, 2-500kcmil, #1/0AWG
500	450	480	(3) 3.5C 3-500kcmil, 2-250kcmil #1/0AWG

**Table 12 Recommended conduit and cable sizes—Load Bank Output**

UPS Rating		Voltage (VAC) Input, Bypass and Output	Load Bank Output Nominal Selection (#) Conduit Size, Ph, N,G
kVA	kW		
6-Pulse Plus Filter Design			
250	225	480	(1) 3-500kcmil, #1/0AWG
300	270	480	(2) 3-#4/0AWG, #1/0AWG
400	360	480	(2) 3-350kcmil, #1/0AWG
500	450	480	(2) 3-500kcmil, #1/0AWG

**Notes on Tables 7 through 12**

See the Liebert NXL UPS installation manual, SL-25420, for UPS rectifier, UPS bypass and UPS output sizes. The manual is available at the Liebert Web site: [www.liebert.com](http://www.liebert.com)

These are guidelines only and are superseded by local regulations and codes of practice where applicable.

- Take special care when determining the size of the neutral cable, because current circulating on the neutral cable may be greater than nominal current in the case of non-linear loads. Refer to the values given in **Tables 8 through 13**. For three-wire systems, the neutral cables and conduit are not required.
- The ground conductor should be sized according to the fault rating, cable lengths, type of protection, etc. The ground cable connecting the UPS to the main ground system must follow the most direct route possible.
- Consideration should be given to the use of smaller, paralleled cables for heavy currents, as a way to ease installation.
- In most installations, the load equipment is connected to a distribution network of individually protected busbars fed by the Maintenance Bypass Cabinet output rather than being connected directly to the Maintenance Bypass Cabinet itself. Where this is the case, the Maintenance Bypass Cabinet output cables can be rated to suit the individual distribution network demands rather than being fully load-rated.
- When laying the power cables, do not form coils to avoid increasing formation of electromagnetic interference.

**Table 13 Recommended lug sizes**

<b>Cable Size</b>	<b>T&amp;B Copper One Hole</b>	<b>T&amp;B Copper Two Hole</b>	<b>T&amp;B Aluminum One Hole</b>	<b>T&amp;B Aluminum Two Hole</b>
#8 AWG	54930BE	54850BE	60104-TB	—
#6 AWG	54905BE	256-30695-868	60109-TB	—
#4 AWG	54906BE	256-30695-733	60114-TB	—
#2-3 AWG	54942BE	54811BE	60120	—
#1 AWG	54947BE	54857BE	60126	—
#1/0 AWG	54950BE	256-30695-593	60132	—
#2/0 AWG	54951BE	54862BE	60138	60238
#3/0 AWG	54965BE	54864BE	60144	60244
#4/0 AWG	54970BE	54866BE	60150	60250
250kcmil	54913BE	54868BE	60156	60256
300kcmil	54914BE	54870BE	60162	60262
350kcmil	54915BE	54872BE	60165	60267
400kcmil	54916BE	54874BE	60168	60269
500kcmil	54918BE	54876BE	60171	60273
600kcmil	54920BE	54878BE	60176	60275
750kcmil	54922BE	54880BE	60178	60277



## **Technical Support / Service**

### **Web Site**

www.liebert.com

### **Monitoring**

liebert.monitoring@emerson.com

800-222-5877

Outside North America: +00800 1155 4499

### **Single-Phase UPS & Server Cabinets**

liebert.upstech@emerson.com

800-222-5877

Outside North America: +00800 1155 4499

### **Three-Phase UPS & Power Systems**

800-543-2378

Outside North America: 614-841-6598

### **Environmental Systems**

800-543-2778

Outside the United States: 614-888-0246

### **Locations**

#### **United States**

1050 Dearborn Drive

P.O. Box 29186

Columbus, OH 43229

#### **Europe**

Via Leonardo Da Vinci 8

Zona Industriale Tognana

35028 Piove Di Sacco (PD) Italy

+39 049 9719 111

Fax: +39 049 5841 257

#### **Asia**

29/F, The Orient Square Building

F. Ortigas Jr. Road, Ortigas Center

Pasig City 1605

Philippines

+63 2 687 6615

Fax: +63 2 730 9572

While every precaution has been taken to ensure the accuracy and completeness of this literature, Liebert Corporation assumes no responsibility and disclaims all liability for damages resulting from use of this information or for any errors or omissions.

© 2013 Liebert Corporation

All rights reserved throughout the world. Specifications subject to change without notice.

© Liebert is a registered trademark of Liebert Corporation.

All names referred to are trademarks

or registered trademarks of their respective owners.

SL-25432\_REV7\_05-16

## **Emerson Network Power**

Division: Liebert

Web: [www.emerson.com](http://www.emerson.com)