

# LIEBERT® NXL™ 250-400kVA, 1+1 (DISTRIBUTED BYPASS) MULTI-MODULE SYSTEM SITE PLANNING DATA

**Table 1 Site planning data—250-400kVA**

UPS Rating		AC Input/Output Voltage, VAC	Input Isolation Transformer	Rectifier AC Input Current		Bypass/Output AC Output Current	Maximum Battery Current at End of Discharge (A)	Maximum Heat Dissipation Full Load, BTU/h (kW)	Dimensions WxDxH, in. (mm)	Approximate Weight Unpacked, lb. (kg)
kVA	kW			Nom	Max	Nom				
250	225	480	NO	312	389	301	615	53,592 (15.7)	71.8x33.5x76.8 (1823x850x1950)	3965 (1798)
250	225	575		260	326	251		53,662 (15.7)	78.5x33.5x76.8 (1993x850x1950)	4975 (2257)
250	225	600		250	312	241		61,890 (18.1)		4840 (2195)
300	270	480		371	464	361	730	64,100 (18.8)	5440 (2468)	
300	270	575		308	386	301		74,173 (21.7)	78.5x39.4x76.8 (1993x1000x1950)	6280 (2849)
300	270	600		296	369	289		86,265 (25.3)	114.5x39.4x76.8 * (2908x1000x1950)	6925 (3141)
400	360	480		497	621	481	980	—	9	9
400	360	575		419	524	402	990	—	9	9
400	360	600		401	502	385	990	—	9	9
See Notes below:				—	1,3,6,7,8,10,11		2,3,4,6,7,8,10,11	5,6,8,10,11	—	9

\* Deduct 16.1 inches (409mm) when battery cabinets are attached.

## Notes for Table 1

- Nominal rectifier AC input current (considered continuous) is based on full rated output load. Maximum current includes nominal input current and maximum battery recharge current (considered non-continuous). Maximum input current is controlled by current limit setting which is adjustable 25 to 125% of nominal input current.
- Bypass AC input and AC output current (considered continuous) is based on full rated output load.
- Vertiv recommends that feeder protection (by others) for the rectifier AC input and the bypass AC input be provided by separate overcurrent protection devices.
- UPS output load cables must be run in separate conduit from input cables.
- Power cable from module DC bus to battery should be sized for a total maximum 2.0V line drop (power cable drop plus return cable drop as measured at the module) at maximum discharge current.
- Grounding conductors to be sized per NEC 250-95. Neutral conductors to be sized for full capacity per NEC 310-16, Note 10 for systems with 4-wire loads and 20% minimum capacity for 3-wire loads.
- NOTE: A neutral conductor is required from each Multi-Module Unit output to the System Switch Board.**
- Rectifier AC Input: 3-phase, 3-wire, plus ground  
Bypass AC Input: 3-phase, 4-wire, plus ground (3-wire plus ground in certain circumstances)  
AC Output to Load: 3-phase, 3- or 4-wire, plus ground  
Module DC Input from Battery: 2-wire (positive and negative), plus ground  
Module Output to SPC: 3-phase, 4-wire, plus ground
- All wiring is to be in accordance with National and Local Electrical Codes.
- Minimum overhead clearance is 2 ft. (0.6m) above the UPS.
- Top or bottom cable entry through removable access plates. Cut plate to suit conduit size.
- Control wiring and power cables must be run in separate conduits. Control wiring must be stranded tinned conductors.
- Dimensions and weights do not include the System Paralleling Cabinet.
- For optimal load sharing performance, the difference in bypass circuit cable length must be 10% or less from longest to shortest. Cable length should be measured from common point of input to common point of output. If needed, contact your Vertiv representative to determine if other lengths are acceptable.



Numbers in this illustration refer to notes below the table on page 1.

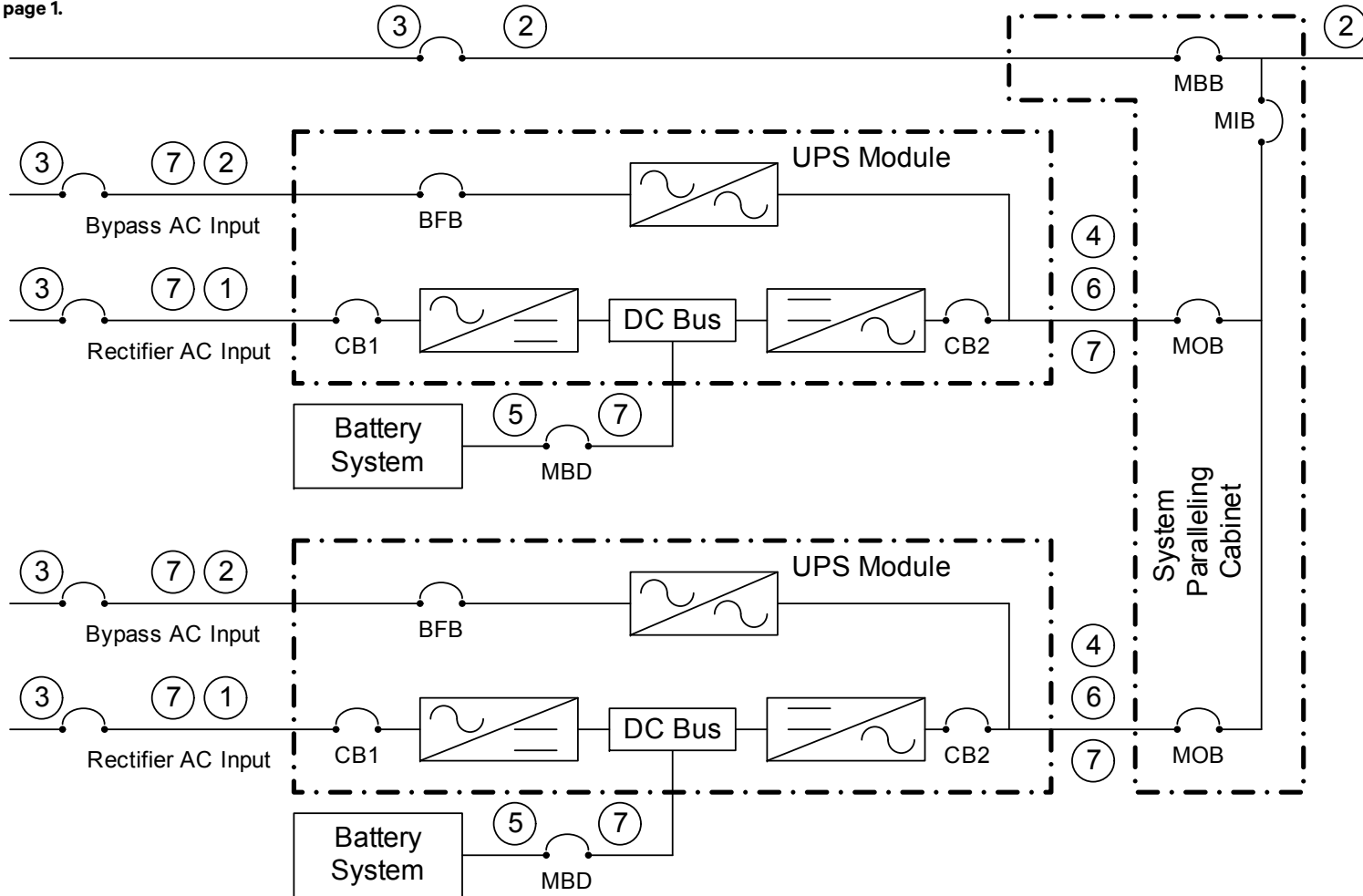

The Liebert NXL is compatible with high resistance ground systems. See your local Vertiv representative for details.



© 2009 Liebert Corporation  
 All rights reserved throughout the world. Specifications subject to change without notice.  
 \* Liebert is a registered trademark of Liebert Corporation.  
 All names referred to are trademarks or registered trademarks of their respective owners.  
 SL-25527\_REV1\_02-17

**Technical Support / Service**

800-543-2378  
 powertech@vertivco.com  
 Web site: www.liebert.com

**United States**

1050 Dearborn Drive  
 P.O. Box 29186  
 Columbus, OH 43229