

# LIEBERT® NXL™ 500-750kVA, N+1 (CENTRAL BYPASS) MULTI-MODULE SYSTEM SITE PLANNING DATA

**Table 1 Site planning data—500-750kVA**

UPS Rating		AC Input/Output Voltage, VAC	Input Isolation Transformer	Rectifier AC Input Current		Bypass/Output AC Current	Maximum Battery Current at End of Discharge (A)	Maximum Heat Dissipation, Full Load, BTU/h (kW)	Dimensions WxDxH, in. (mm)	Approx. Weight Unpacked, lb. (kg)
kVA	kW			Nom	Max	Nom				
500	450	480	YES	643	804	601	1250	124,805 (36.6)	111.6x39.4x76.8 (2835x1000x1950)	10,210 (4631)
625	562.5	480		799	995	752	1530	167,265 (49.0)	125x39.4x76.8 (3174x1000x1950)	13,100 (5942)
750	675	480		975	1219	902	1845	213,587 (62.6)		
750	675	575		815	1018	753	1851	215,790 (63.2)		
750	675	600		759	949	722	1851	200,173 (58.7)		
See Notes below:			—	1,3,6,7,8,10,11		2,3,4,6,7,8,10,11	5,6,7,8,10,11	—	9,12	9,12

**Notes for Table 1**

- Nominal rectifier AC input current (considered continuous) is based on full rated output load. Maximum current includes nominal input current and maximum battery recharge current (considered non-continuous). Maximum input current is controlled by current limit setting which is adjustable 25 to 125% of nominal input current.
- AC output current (considered continuous) is based on full rated output load.
- Vertiv recommends that feeder protection (by others) for the rectifier AC input and the bypass AC input be provided by separate overcurrent protection devices.
- UPS output load cables must be run in separate conduit from input cables.
- Power cable from module DC bus to battery should be sized for a total maximum 2.0V line drop (power cable drop plus return cable drop as measured at the module) at maximum discharge current.
- Grounding conductors to be sized per NEC 250-95. Neutral conductors to be sized for full capacity-per NEC 310-16, Note 10-for systems with 4-wire loads and 20% minimum capacity for 3-wire loads.  
**NOTE:** A neutral conductor is required from each multi-module unit output to the system bypass switchgear.
- Rectifier AC Input: 3-phase, 3-wire, plus ground  
Bypass AC Input: 3-phase, 4-wire, plus ground (3-wire plus ground in certain circumstances)  
AC Output to Load: 3-phase, 3- or 4-wire, plus ground  
Module DC Input from Battery: 2-wire (positive and negative), plus ground  
Module Output to SCC: 3-phase, 4-wire, plus ground
- All wiring is to be in accordance with National and Local Electrical Codes.
- Minimum overhead clearance is 2 ft. (0.6m) above the UPS.
- Top or bottom cable entry through removable access plates. Cut plate to suit conduit size.
- Control wiring and power cables must be run in separate conduits. Control wiring must be stranded tinned conductors.
- Dimensions and weights do not include the System Control Cabinet required for Multi-Module Systems.



Numbers in this illustration refer to notes below the table on page 1.

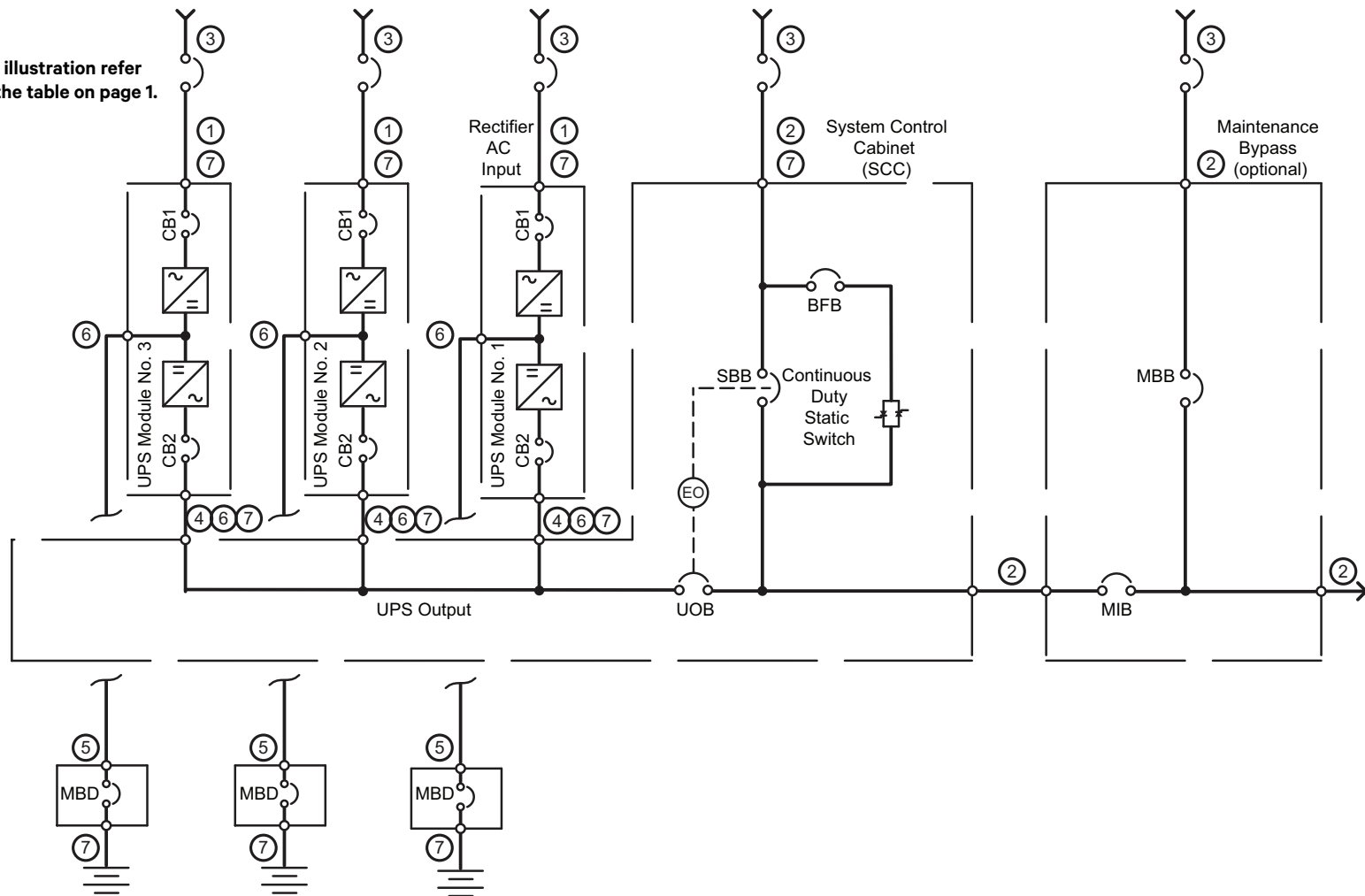

The Liebert NXL is compatible with High Resistance Ground Systems. See your local Vertiv representative for details.



© 2009 Liebert Corporation  
 All rights reserved throughout the world. Specifications subject to change without notice.  
 \* Liebert is a registered trademark of Liebert Corporation.  
 All names referred to are trademarks or registered trademarks of their respective owners.  
 SL-25518\_REV6\_02-17

**Technical Support / Service**

800-543-2378  
 powertech@vertivco.com  
 Web site: www.liebert.com

**United States**

1050 Dearborn Drive  
 P.O. Box 29186  
 Columbus, OH 43229