



# Liebert® EXM™ 480V External Battery Cabinet

User Manual

---

©2016 Vertiv Co. All rights reserved throughout the world.

This document may contain confidential and/or proprietary information of Liebert Corporation, and its receipt or possession does not convey any right to reproduce, disclose its contents, or to manufacture or sell anything that it may describe. Reproduction, disclosure, or use without specific authorization from Liebert Corporation is strictly prohibited.

---

---

# TABLE OF CONTENTS

<b>IMPORTANT SAFETY INSTRUCTIONS</b> .....	<b>1</b>
<b>SAVE THESE INSTRUCTIONS</b> .....	<b>1</b>
<b>1.0 MECHANICAL INSTALLATION</b> .....	<b>5</b>
1.1 Introduction .....	5
1.2 System Composition .....	5
1.3 Preliminary Checks .....	5
1.4 Environmental Considerations .....	5
1.4.1 Battery Room .....	5
1.4.2 Storing Batteries for Delayed Installation .....	5
1.4.3 Installation Considerations .....	6
1.5 Moving the Battery Cabinets .....	7
1.5.1 Raised-Floor Mounting .....	7
1.6 Layout .....	8
1.6.1 Connecting the Liebert EXM Battery Cabinet to the UPS .....	8
<b>2.0 BATTERY INSTALLATION</b> .....	<b>10</b>
2.1 Safety .....	10
2.1.1 Connecting the Batteries .....	11
2.2 Power Connection .....	11
2.2.1 Connected System .....	11
2.2.2 Stand-Alone and Right-Mounted Systems .....	11
2.2.3 Grounding .....	11
2.3 Control Connection .....	12
2.4 Non-Standard Batteries .....	12
2.5 Batteries Approved for Use in Liebert EXM Systems .....	17
2.5.1 Floor Installation .....	17
2.5.2 Cable Entry .....	17
2.6 Static Bypass Assembly .....	18
2.7 Control Wiring .....	18
2.7.1 Battery Cabinet Interface Connectors .....	18
2.8 Alber® BDSUi™ Battery Monitoring System—Optional .....	22
2.9 Connecting an Alber® BDSUi-UXBM/50™ .....	23
2.9.1 Accessory Fuses and Back-Feed Breaker Wiring .....	24
2.10 Battery Protection .....	24
2.10.1 Battery Low-Voltage Warning .....	24
2.10.2 Battery End-of-Discharge (EOD) Protection .....	24
<b>3.0 INSTALLATION DRAWINGS</b> .....	<b>25</b>
<b>4.0 SPECIFICATIONS</b> .....	<b>27</b>
<b>5.0 MAINTENANCE</b> .....	<b>30</b>
5.1 Record Log .....	30
5.2 Battery Maintenance .....	30
5.3 Battery Safety Precautions .....	30
5.4 Torque Requirements .....	32

---

## FIGURES

Figure 1	Battery cabinets connected, attached to UPS .....	8
Figure 2	Bolting the Liebert EXM Battery Cabinet to the Liebert EXM UPS.....	9
Figure 3	Power cabling for 50-250kVA UPS.....	9
Figure 4	Battery cabinet terminal detail, 880mm cabinet; 50-250kVA UPS .....	13
Figure 5	Battery cabinet terminal detail, 1200mm cabinet; 50-250kVA UPS .....	14
Figure 6	Liebert EXM UPS terminal detail 200kVA .....	15
Figure 7	Liebert EXM UPS terminal detail 250kVA .....	16
Figure 8	Static Bypass Assembly connections .....	18
Figure 9	Single battery cabinet connection to Liebert EXM.....	19
Figure 10	Alber BDSUi-UXCM rear panel.....	22
Figure 11	Alber BDSUi-UXBM/50 rear panel .....	23
Figure 12	Alber® battery cabinet monitoring assembly diagram.....	24
Figure 13	Battery cabinet outline drawing and main components—880mm cabinet.....	25
Figure 14	Battery cabinet outline and main components—1200mm cabinet .....	26
Figure 15	Battery, circuit breaker and UPS wiring with external batteries with two connecting wires.....	29

## TABLES

Table 1	Control wiring for Liebert EXM to battery cabinet .....	9
Table 2	Interconnect wiring for UPS to battery cabinet .....	14
Table 3	Batteries approved for use in Liebert EXM External Battery Cabinet, 880mm .....	17
Table 4	Batteries approved for use in Liebert EXM External Battery Cabinet, 1200mm .....	17
Table 5	Battery cabinet interface—J22 .....	18
Table 6	Battery voltage, nominal and float .....	19
Table 7	Alber UXCM rear panel features .....	22
Table 8	Alber UXCM rear panel features .....	23
Table 9	Physical standards and parameters .....	27
Table 10	Battery cabinet system—UPS and Liebert EXM Battery Cabinet .....	27
Table 11	Battery DC intermediate circuit.....	28
Table 12	Battery short circuit currents .....	28
Table 13	1200mm battery cabinet mechanical characteristics.....	29
Table 14	880mm battery cabinet mechanical characteristics.....	29
Table 15	Busbars (for power wiring) .....	32
Table 16	Terminal block with compression lugs (for control wiring) .....	32
Table 17	Battery retorque values .....	33

# IMPORTANT SAFETY INSTRUCTIONS

## SAVE THESE INSTRUCTIONS

This manual contains important instructions that should be followed during installation of your Liebert EXM 480V Battery Cabinet and accessories. Read this manual thoroughly, paying special attention to the sections that apply to your installation, before working with the battery system. Retain this manual for use by installing personnel.

The following warning applies to all battery cabinets supplied with UPS systems..

### **WARNING**

Internal battery strapping must be verified prior to moving a battery cabinet (after initial installation).

- Battery cabinets contain non-spillable batteries.
- Keep units upright.
- Do not stack.
- Do not tilt.

Failure to heed this warning could result in smoke, fire or electric hazard.

Call 1-800-LIEBERT prior to moving battery cabinets (after initial installation).

### **AVERTISSEMENT**

L'arrimage des batteries internes doit être vérifié avant de déplacer une armoire de batteries (après l'installation initiale).

- Les armoires de batteries contiennent des batteries étanches.
- Maintenir les systèmes à la verticale.
- Ne pas empiler.
- Ne pas incliner.

Le non-respect de ces consignes comporte des risques liés à la fumée, au feu ou à l'électricité.

Composez le 1 800 LIEBERT avant de déplacer des armoires de batteries (après l'installation initiale).

## **WARNING**

Risk of electrical shock. Can cause personal injury and death.

Check for voltage with both AC and DC voltmeters before working within the UPS. Check for voltage with both AC and DC voltmeters before making contact.

Only properly trained and qualified personnel wearing appropriate safety headgear, gloves, shoes and glasses should be involved in installing the UPS or preparing the UPS for installation. When performing maintenance with any part of the equipment under power, service personnel and test equipment should be standing on rubber mats.

Lead-acid batteries contain hazardous materials. Batteries must be handled, transported and recycled or discarded in accordance with federal, state and local regulations. Because lead is a toxic substance, lead-acid batteries must be recycled rather than discarded.

Do not dispose of battery or batteries in a fire. The battery may explode.

Do not open or mutilate the battery or batteries. Released electrolyte is harmful to the skin and eyes. It is toxic.

The following precautions must be observed when working on batteries:

- Remove watches, rings and other metal objects.
- Use tools with insulated handles.
- Wear rubber gloves and boots.
- Do not lay tools or metal parts on top of batteries.
- Disconnect charging source prior to connecting or disconnecting battery terminals.
- Determine whether the battery is grounded. If it is grounded, remove source of ground.

Contact with any part of a grounded battery can result in electrical shock. The likelihood of such shock will be reduced if such grounds are removed during installation and maintenance.

## **AVERTISSEMENT**

Risque de décharge électrique pouvant causer des blessures graves, voire mortelles.

Vérifiez les tensions au moyen de voltmètres c.a. et c.c. avant d'utiliser le système ASC. Vérifiez les tensions avec des voltmètres c.a. et c.c. avant d'établir tout contact.

Seuls des employés qualifiés et dûment formés portant un casque, des gants, des chaussures et des lunettes de sécurité adéquats doivent se charger d'installer le système ASC ou de le préparer pour l'installation. Les responsables de l'entretien et l'équipement d'essai doivent reposer sur des tapis de caoutchouc lors de toute intervention sur une pièce d'équipement sous tension.

Les batteries au plomb-acide renferment des matières dangereuses. Les batteries doivent être manipulées, transportées, recyclées ou jetées conformément aux règlements fédéraux, provinciaux et municipaux. Étant donné que le plomb est une substance toxique, les batteries au plomb-acide doivent être recyclées plutôt que mises au rebut.

Ne jetez jamais de batteries au feu car elles risquent d'exploser.

Vous ne devez ni ouvrir ni percer les batteries, car l'électrolyte qui s'en écoulerait est nocif pour la peau et les yeux. Cet électrolyte est toxique.

Lorsque vous travaillez avec des batteries, prenez les précautions suivantes :

- Retirez montre, bagues et tout autre objet métallique.
- Utilisez des outils dont le manche est isolé.
- Portez des gants et des bottes de caoutchouc.
- Ne posez aucun outil ni pièce métallique sur le dessus d'une batterie.
- Déconnectez la source de chargement avant de brancher ou de débrancher les bornes d'une batterie.
- Vérifiez si la batterie est mise à la terre. Le cas échéant, éliminez la cause de la mise à la terre.

Le contact avec toute partie d'une batterie mise à la terre peut provoquer une décharge électrique. Pour réduire de tels risques d'accident, débranchez les prises de terre avant de procéder à l'installation ou à l'entretien.

## **WARNING**

Risk of electric shock. Can cause personal injury and death.

In case of fire involving electrical equipment, use only carbon dioxide fire extinguishers or those approved for use in fighting electrical fires.

## **AVERTISSEMENT**

Risque de décharge électrique pouvant causer des blessures graves, voire mortelles.

En cas d'incendie associé à du matériel électrique, n'utilisez que des extincteurs à dioxyde de carbone ou homologués pour la lutte contre les incendies d'origine électrique.

## **WARNING**

Risk of heavy unit falling over. Improper handling can cause equipment damage, injury or death.

Exercise extreme care when handling battery cabinets to avoid equipment damage or injury to personnel. The battery system cabinets weigh from 1820 to 4907 lb. (826 to 2226kg).

Locate center of gravity symbols  and determine unit weight before handling each cabinet. Test lift and balance the cabinets before transporting. Maintain minimum tilt from vertical at all times.

Slots at the base of the module cabinets are intended for forklift use. Base slots will support the unit only if the forks are completely beneath the unit.

Read all of the following instructions before attempting to move, lift, or remove packaging from unit, or prepare unit for installation.

## **AVERTISSEMENT**

Le centre de gravité élevé de l'appareil présente un risque de renversement. Une mauvaise manutention peut entraîner des dommages matériels, des blessures et même la mort.

Faites preuve d'une extrême prudence lors de la manutention des armoires ASC afin d'éviter de les endommager ou de blesser le personnel. Le poids du module ASC varie entre 826 et 2 226 kg (1 820 et 4907 lb).

Identifiez les symboles de centre de gravité  et déterminez le poids de l'appareil avant de manipuler chaque armoire. Testez le levage et l'équilibre des armoires avant de transporter l'appareil. Maintenez en tout temps l'inclinaison verticale minimale.

Les fentes situées à la base des armoires du module sont conçues pour utiliser le chariot élévateur. Les fentes situées à la base peuvent soutenir le système seulement si les fourches se trouvent complètement sous le système.

Lisez toutes les instructions ci-dessous avant de tenter de déplacer, lever, déballer ou préparer le système en vue de son installation.

## **WARNING**

Risk of electrical shock and fire. Can cause equipment damage, personal injury or death.

Under typical operation and with all UPS doors closed, only normal safety precautions are necessary. The area around the UPS system should be kept free of puddles of water, excess moisture and debris.

Only test equipment designed for troubleshooting should be used. This is particularly true for oscilloscopes. Always check with an AC and DC voltmeter to ensure safety before making contact or using tools. Even when the power is turned Off, dangerously high potential electric charges may exist at the capacitor banks and at the DC connections.

All wiring must be installed by a properly trained and qualified electrician. All power and control wiring must comply with all applicable national, state and local codes.

One person should never work alone, even if all power is disconnected from the equipment. A second person should be standing by to assist and to summon help in case of an accident.

## **AVERTISSEMENT**

Risque de décharge électrique et d'incendie. Pouvant entraîner des dommages matériels, des blessures et même la mort.

Les précautions de sécurité habituelles suffisent lorsque le système ASC est en mode de fonctionnement normal et que toutes les portes sont fermées. La zone entourant le système ASC doit être exempte de flaques d'eau, d'humidité excessive et de débris.

Seuls des équipements d'essai conçus pour le dépannage doivent être utilisés. Cette mise en garde couvre notamment les oscilloscopes. Utilisez toujours un voltmètre c.a. et c.c. pour vérifier les tensions avant d'établir un contact ou d'utiliser des appareils. Des tensions dangereusement élevées peuvent demeurer dans les batteries de condensateurs et au niveau des raccords c.c., même une fois l'alimentation coupée.

Tous les raccords doivent être effectués par un électricien dûment formé et qualifié. Tous les câbles d'alimentation et de commande doivent être conformes aux codes nationaux et locaux en vigueur.

Une personne ne devrait jamais travailler seule, même si toute l'alimentation d'entrée est coupée. Une deuxième personne devrait toujours être présente pour porter assistance ou chercher de l'aide en cas d'accident.

## **NOTICE**

This unit complies with the limits for a Class A digital device, pursuant to Part 15 Subpart J of the FCC rules. These limits provide reasonable protection against harmful interference in a commercial environment. This unit generates, uses and radiates radio frequency energy and, if not installed and used in accordance with this instruction manual, may cause harmful interference to radio communications. Operation of this unit in a residential area may cause harmful interference that the user must correct at his own expense.



# 1.0 MECHANICAL INSTALLATION

## 1.1 INTRODUCTION

This following section describes the requirements that must be taken into account when planning the positioning and cabling of the Liebert EXM battery equipment.

This chapter is a guide to general procedures and practices that should be observed by the installing engineer. The particular conditions of each site will determine the applicability of such procedures.

### NOTICE

Risk of improper startup. Can cause equipment damage.

Do not apply electrical power to the UPS equipment before the arrival of the commissioning engineer.

## 1.2 SYSTEM COMPOSITION

A battery system can consist of a number of equipment cabinets, depending on the individual system design requirements, e.g., Battery Cabinet. Refer to **3.0 - Installation Drawings** for positioning the cabinets.

## 1.3 PRELIMINARY CHECKS

Before installing the battery equipment, carry out the following preliminary checks:

- Remove all panels and visually inspect the cabinet, batteries, bus connections and cabinet for any shipping damage. Exercise caution; voltage is present within the battery cabinet even before installation. If there are signs of damage, do not proceed. Call Liebert Services at 1-800-542-2378.
- Report any damage to the shipper immediately.
- Verify that the correct equipment is being installed. The equipment supplied has an identification tag inside the main door.
- Verify that the battery room satisfies the environmental conditions stipulated in the equipment specification, paying particular attention to the ambient temperature and air exchange system.

## 1.4 ENVIRONMENTAL CONSIDERATIONS

### 1.4.1 Battery Room

Batteries should be installed in an environment where the temperature is consistent and even over the whole battery. Temperature is a major factor in determining the battery life and capacity. Typical battery manufacturer performance data are quoted for an operating temperature between 68°F and 77°F (20 and 25°C). Operating above this range will reduce the battery life while operation below this range will reduce the battery capacity.

**Battery Temperature**—In a normal installation, the battery temperature should be kept between 59 and 77°F (15°C and 25°C).



### NOTE

*Keep batteries away from main heat sources, main air inlets, etc.*

### 1.4.2 Storing Batteries for Delayed Installation

If the battery system will not be installed immediately, it must be stored indoors in a clean, dry and cool location. Batteries should be unpacked, installed and charged as soon as possible after delivery.

### NOTICE

Risk of failure to properly charge batteries. Can cause permanent damage to batteries and void the warranty.

Batteries will self-discharge during storage. Batteries must be recharged as recommended by the battery manufacturer.

A notice of “Charge Before Date” is affixed to each unit that has batteries inside. The “Charge Before Date” is calculated based on the batteries being stored at 77°F (25°C). Storage at a higher temperature will increase the rate of self-discharge, requiring earlier recharge. Consult the battery manufacturer on how to determine when the batteries need to be recharged.

### 1.4.3 Installation Considerations

**Position**—Refer to UPS manual (SL-26102 for 50-250kVA units) or submittals for complete system line-up details. Liebert EXM Battery Cabinet(s) are designed to be located next to each UPS module on the left side only and are also available in stand-alone configurations with painted side panels. The front access design eliminates side and rear service clearance requirements. Refer to **Tables 13** and **14** for battery cabinet dimensions and weights.

**Bolt-On Cabinets**—Matching battery cabinets are designed to bolt only onto the left side of the UPS module cabinet. Use bolts that ship with each unit to connect cabinet frames at posts, two places in the front and two places in the rear.

**Service Clearance**—Allow front access to the battery cabinet at all times for maintenance and service. Electrical codes require that the battery cabinet be installed with no less than 3 ft. (1m) of clearance at the front of the cabinet when operating. No service clearance is required on either the side or rear. Clearance at the top of the cabinet is 24" (610mm).

**Cables (50-250kVA Units)**—Cables may be run between the cabinets through cutouts in the top of the cabinet, eliminating the need for external conduit runs. Route cables before moving cabinets into final position for bolting together. No top or bottom entry cables are required, except for remotely located cabinets which require conduits.

Power terminals, auxiliary terminals blocks and circuit breakers are accessed from the front and top.

Removable panels on the top are secured to the chassis by screws. The door can be opened to give access to the power connections bars, auxiliary terminal blocks and breakers. The front door can be opened 180° for easier service and more flexibility in installation.

**Software**—To allow the UPS to accurately display the battery run time, the number of battery cabinets must be noted when performing initial startup and setup using the configuration software. This is to be performed by the Liebert Services engineer when commissioning the unit.

**Casters and Adjustable Stops**—The adjustable stops are not designed to bear the full weight of the cabinet. Lower the stops until they are finger-tight in contact with the floor. Then tighten a small amount with a wrench (less than two turns) to give a good friction fit. When mounting the battery cabinet on seismic stands, ensure that the casters are bearing the weight of the cabinet.

## 1.5 MOVING THE BATTERY CABINETS

The battery cabinets should be moved with a forklift or similar equipment. The battery cabinet has casters for movement over short distances. The bottoms of the battery cabinets are reinforced to permit lifting by forklift to move them longer distances. The bottom structure will support the unit only if the forks are completely beneath the unit.

The route between the point of arrival and the unit's installation location must be planned to make sure that all passages are wide enough for the unit and that floors will support its weight (for instance, check that doorways, lifts, ramps, etc., are big enough and that there are no impassable corners or changes in the level of corridors).

Ensure that the cabinet weight is within the designated surface weight loading (kg/cm<sup>2</sup>) of any handling equipment. See **Tables 13** through **14** for weight details.

Ensure that any lifting equipment used to move the battery equipment has sufficient lifting capacity.

Because the weight distribution in the cabinet is not symmetrical, use extreme care during handling and transporting.

When moving the unit by forklift, care must be taken to protect the panels.

Handling the unit with straps is not authorized.

### **WARNING**

Risk of heavy unit falling over. Improper handling can cause equipment damage, injury or death.

Exercise extreme care when handling battery cabinets to avoid equipment damage or injury to personnel.

The battery system cabinets weigh from 1820 to 4907 lb. (826 to 2226kg).

Locate center of gravity symbols  and determine the unit's weight before handling a cabinet. Test lift and balance the cabinets before moving them. Maintain minimum tilt from vertical at all times.

Read all of the following instructions before attempting to move, lift, or remove packaging from unit, or prepare unit for installation.

### **AVERTISSEMENT**

Le centre de gravité élevé de l'appareil présente un risque de renversement. Une mauvaise manutention peut entraîner des dommages matériels, des blessures et même la mort.

Faites preuve d'une extrême prudence lors de la manutention des armoires ASC afin d'éviter de les endommager ou de blesser le personnel. Le poids du module ASC varie entre 826 et 2 226 kg (1820 et 4 907 lb).

Identifiez les symboles de centre de gravité  et déterminez le poids de l'appareil avant de manipuler chaque armoire. Testez le levage et l'équilibre des armoires avant de transporter l'appareil. Maintenez en tout temps l'inclinaison verticale minimale.

Lisez toutes les instructions ci-dessous avant de tenter de déplacer, lever, déballer ou préparer le système en vue de son installation.

### 1.5.1 Raised-Floor Mounting

If the equipment is to be placed on a raised floor, it should be mounted on a pedestal suitably designed to accept the equipment point loading. Refer to the base view to design this pedestal.

## 1.6 LAYOUT

Depending on the site layout, the battery cabinets can be installed in any of several ways:

- Connected—Multiple battery cabinets bolted together
- Stand-Alone System—Cabinets not bolted to a Liebert EXM

See **Figure 1**.

**Figure 1 Battery cabinets connected, attached to UPS**

**RECOMMENDED INSTALLATION**  
Battery cabinet systems ordered as left-side installation will include factory-supplied cabling to connect the battery system to the 10-120kVA UPS models. The cables will be routed internally.

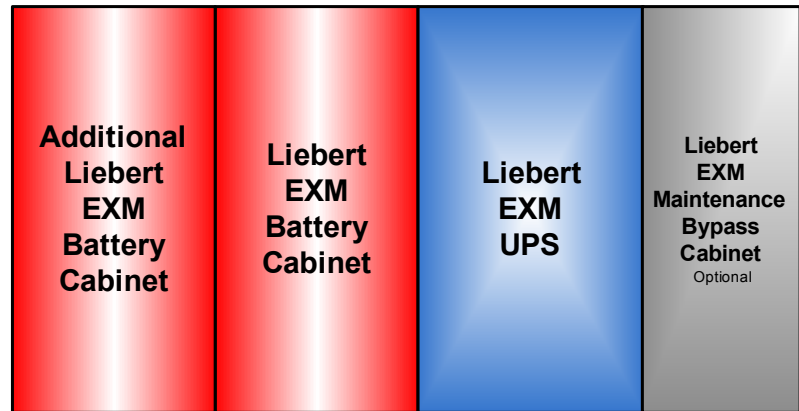

**ALTERNATE INSTALLATION**  
*Without attached Maintenance Bypass Cabinet*  
Battery cabinets may be mounted to the right of the UPS, but all cabling between the battery cabinets and the 10-120kVA UPS models must be external and performed by others.

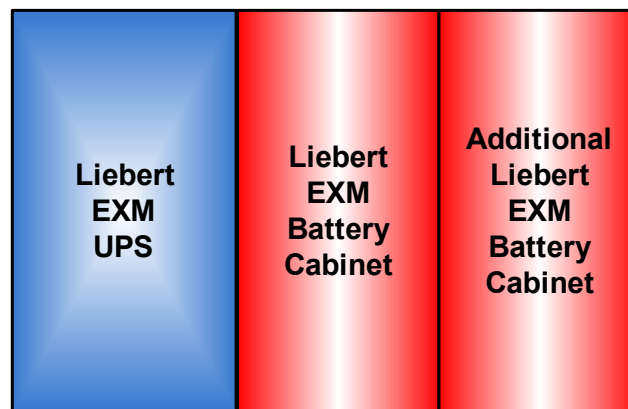

### 1.6.1 Connecting the Liebert EXM Battery Cabinet to the UPS

After the battery cabinet equipment has been positioned and secured for operation and the batteries have been connected, connect the power cables as described below (see **Figure 9**).

1. Verify that all incoming high and low voltage power circuits are de-energized and locked out or tagged out before installing cables or making any electrical connections.
2. Remove the UPS front input output panel to gain access to the ground and battery busbars.
3. Remove the battery cabinet front panel to gain access to the busbars.
4. Connect the safety ground and any necessary bonding ground cables to the copper ground busbar. (example: UPS located behind the output busbars.).

All cabinets in the UPS system must be connected to the user's ground connection.



#### NOTE

*The grounding arrangement must be in accordance with the National Electrical Code and all applicable local codes.*

5. Connect the system battery cables from the UPS battery terminals (+, -) to battery cabinet breaker BCB (+, -) as shown in **Figure 9**. Be sure that the battery connections are made with the right polarity, and tighten the connections to the torque specified in **Table 15**. Do not close the battery circuit breaker before the equipment has been commissioned.

6. Connect TB1 from battery cabinet to J22 on the UPS according to **Table 1**.



**NOTE**

The shunt trip drive capability for the battery breaker is 220VDC at 2.4A.

**Figure 2 Bolting the Liebert EXM Battery Cabinet to the Liebert EXM UPS**

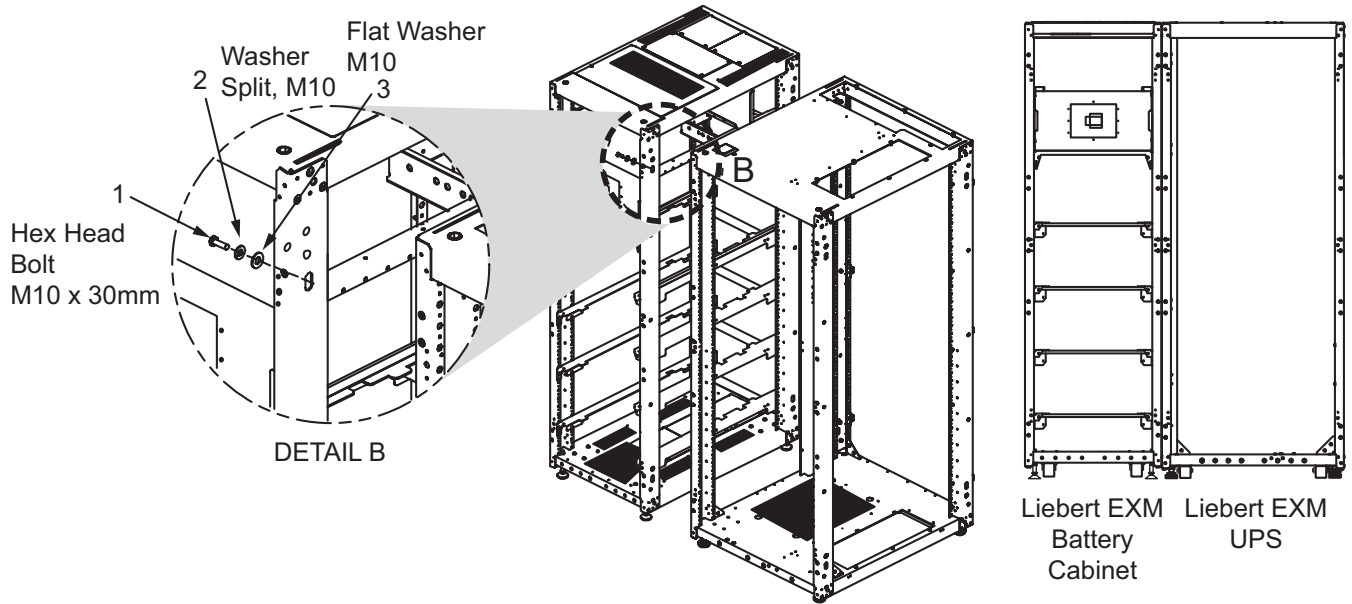

**Table 1 Control wiring for Liebert EXM to battery cabinet**

From	To
Liebert EXM UPS Bypass Module (J22)	Battery Cabinet Terminal Strip (TB1)
J22.15	TB1-12
J22.13	TB1-11
J22.11	TB1-10
J22.1	TB1-6
J22.3	TB1-7
J22.5	TB1-8
J22.7	TB1-9

**Figure 3 Power cabling for 50-250kVA UPS**

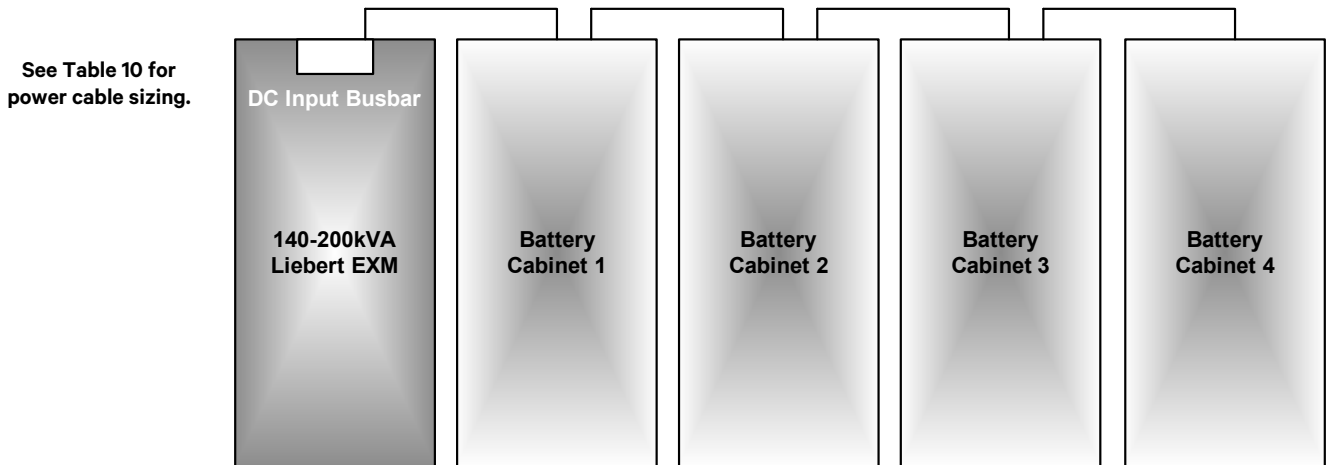

## 2.0 BATTERY INSTALLATION

### 2.1 SAFETY

Special care should be taken when working with the batteries associated with the Liebert EXM Battery System equipment. When all the cells are connected together, the battery terminal voltage will exceed 432VDC and is potentially lethal. A primary safety consideration is to install the battery equipment in an isolated area, accessible only to properly trained and qualified maintenance personnel.

#### **WARNING**

Risk of electrical shock and fire. Can cause equipment damage, personal injury or death.

Servicing of batteries should be performed or supervised by personnel knowledgeable of batteries and the required precautions. Keep unauthorized personnel away from batteries.

#### **AVERTISSEMENT**

Risque de décharge électrique et d'incendie. Pouvant entraîner des dommages matériels, des blessures et même la mort.

Le remplacement des batteries doit être effectué ou supervisé par des membres du personnel dotés des compétences requises et connaissant les précautions à prendre. Le personnel non autorisé ne doit pas avoir accès aux batteries.

Lead-acid batteries can present a risk of fire because they generate hydrogen gas. In addition, the electrical connections must be protected against accidental short circuits which can cause sparks. The following procedures should be followed:

- DO NOT SMOKE when near batteries.
- DO NOT cause flame or spark in battery area.
- Discharge static electricity from body before touching batteries by first touching a grounded metal surface.
- After replacing battery jars in a battery cabinet, replace the retaining straps that hold the jars in place on the shelves. This will limit accidental movement of the jars and connectors should the cabinet ever need to be repositioned or relocated.

Regular maintenance of the battery module is an absolute necessity. Periodic inspections of battery and terminal voltages, specific gravity and connection resistance should be made. Strictly follow the procedures outlined in the battery manufacturer's manual, available on the manufacturer's Web site.

Valve-regulated lead-acid (sealed-cell) batteries do require periodic maintenance. Although maintenance of electrolyte levels is not required, visual inspections and checks of battery voltage and connection resistance should be made.

#### **NOTICE**

Risk of equipment damage. Batteries should be cleaned with a dry cloth or a cloth lightly moistened with water. Do not use cleaners on the batteries. Solvents can make the battery cases brittle.

Because individual battery characteristics are not identical and may change over time, the UPS module is equipped with circuitry to equalize battery cell voltages. This circuit increases charging voltage to maintain flooded type battery cells at full capacity.

#### **WARNING**

Risk of electric shock, explosive reaction, hazardous chemicals and fire. Can cause equipment damage, personal injury and death.

Do not use equalize charging with valve-regulated, lead-acid batteries, such as those in Liebert Battery Cabinets. Refer to the battery manufacturer's manual, available on the manufacturer's Web site, for specific information about equalize charging.

## AVERTISSEMENT

Risque de décharge électrique, de réaction explosive, d'incendie et d'exposition à des produits chimiques dangereux pouvant entraîner des dommages matériels, des blessures et même la mort.

N'utilisez pas de charge d'égalisation avec des batteries d'accumulateurs au plomb à régulation par soupape, comme celles utilisées dans les armoires de batterie Liebert. Reportez-vous au manuel du fabricant des batteries, disponible sur le site Web du fabricant, pour obtenir des renseignements précis sur la charge d'égalisation.

The following general battery safety precautions and warnings must be observed at all times:

- A battery can present risk of electric shock or burn from high short circuit currents.
- When connected in a string, the voltage will exceed 432VDC. This voltage is potentially lethal. Always observe high-voltage precautions.
- Eye protection must be worn to prevent injury from accidental electrical arcs.
- Remove rings, watches, necklaces, bracelets and all other metal objects.
- Use only tools with insulated handles.
- Wear appropriate personal protective equipment when handling batteries.
- If a battery leaks electrolyte or is otherwise physically damaged, it should be placed in a container resistant to wire and disposed of in accordance with local regulations.
- If electrolyte comes into contact with the skin, the affected area should be washed immediately with plenty of clean water.
- Batteries must always be disposed of according to local environmental laws.
- When replacing batteries, use the same number and type that were originally fitted.
- Disconnect charging source prior to connecting or disconnecting battery terminals.
- Determine if the battery is grounded. If it is grounded, remove source of ground. Contact with any part of a grounded battery can result in electrical shock.
- Battery support tray must be used whenever a battery tray is being pulled out.

### 2.1.1 Connecting the Batteries

If the Liebert EXM battery cabinet is installed on a raised floor, the battery power cables and circuit breaker control cables may be routed to the UPS cabinet through the bottom of the cabinet.

If the Liebert EXM battery cabinets are installed adjacent to one another on a solid floor, these cables may be passed between the cabinets through the sides of the cabinets.

Intertray connections must be made before the battery cabinet may be used.

## 2.2 POWER CONNECTION

Depending on the site layout, the battery cabinets can be cabled as shown in **Figure 1**.

### 2.2.1 Connected System

For cabinets ordered as connected (battery cabinets will bolt to each other), the busbars are connected between battery cabinets with the supplied power cables.

### 2.2.2 Stand-Alone and Right-Mounted Systems

The customer must supply all interconnecting cables and hardware for stand-alone and right-mounted cabinets. See **Table 10** for current ratings and recommended cable sizes according to local codes.

### 2.2.3 Grounding

The ground cables and hardware will be supplied for cabinets ordered as connected or attached. The customer must supply the cables and hardware for detached and stand-alone cabinets. Size grounding conductor according to local codes. See terminal detail drawings for the location of the ground busbar.

## 2.3 CONTROL CONNECTION

Each Liebert EXM Battery Cabinet contains a Battery Interface Board (BIB). See **2.7 - Control Wiring**. See **Figure 9** and **Table 1** for control wiring between the Liebert EXM Battery Cabinet and the Liebert EXM UPS. See **Figures 4** through **7** for battery cabinet terminal details



### NOTE

*Care must be taken to route the control cables away from high voltage cables or busbars.*

## 2.4 NON-STANDARD BATTERIES

When batteries other than a matching battery cabinet are used, a remote battery disconnect switch with overcurrent protection is required per the National Electrical Code. Contact your local Vertiv sales representative about this option. Refer to **Figure 15** for details.

Install battery racks, cabinets and batteries in accordance with the manufacturer's instructions.

Verify that the battery area has adequate ventilation and battery operating temperature complies with the manufacturer's specifications and with all applicable national and local codes.

If you have any questions concerning batteries, battery racks or accessories, contact Liebert Services at 1-800-543-2378.



### NOTE

*The user-supplied battery DC bypass breakers or fuses should have a minimum overload rating of 8kA and 500V.*



Figure 4 Battery cabinet terminal detail, 880mm cabinet; 50-250kVA UPS

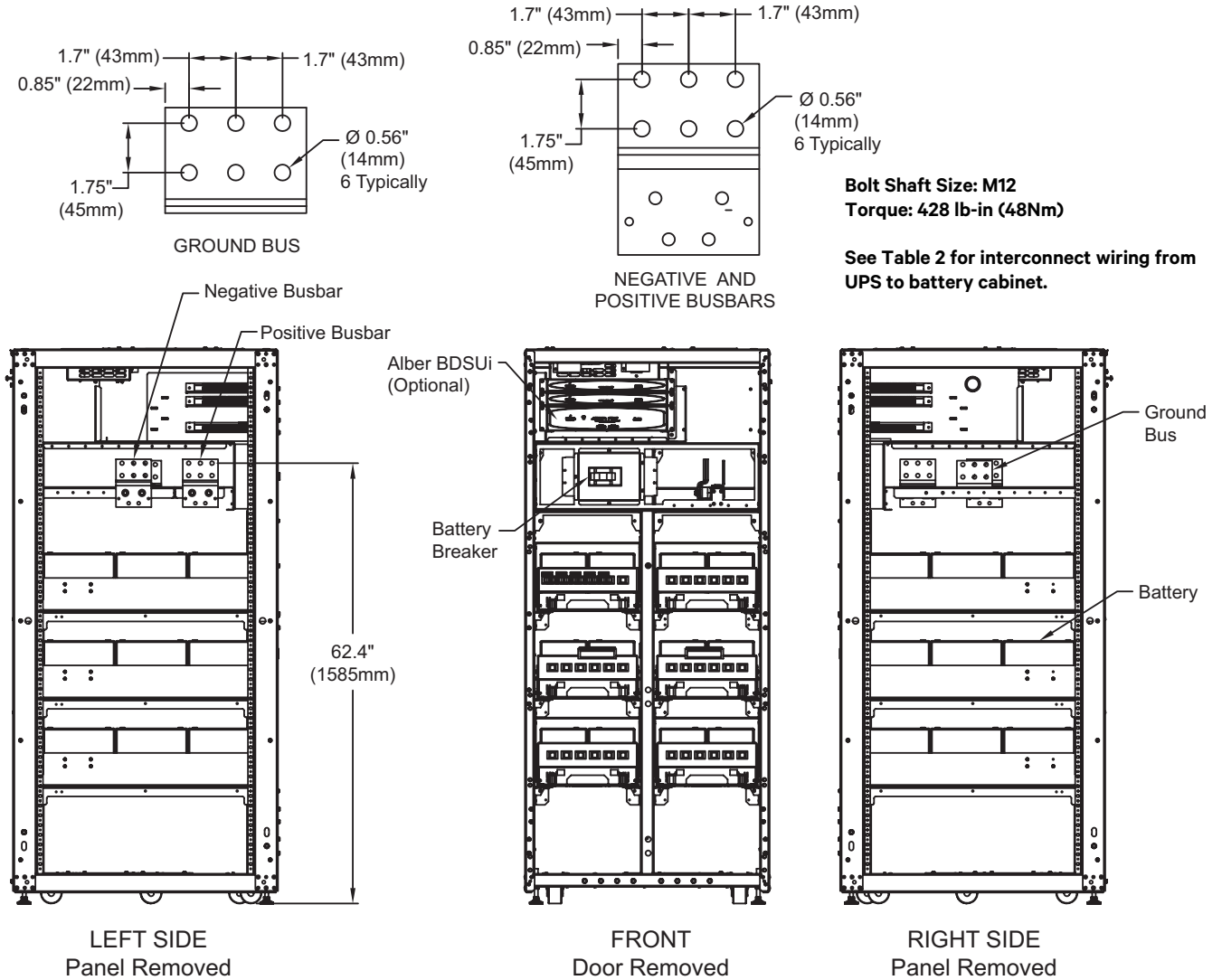

1. Control wiring and power wiring must be run in separate conduits.
2. Vertiv recommends using only copper cables.
3. All wiring must be in accordance with national and local electrical codes.
4. Vertiv will supply interconnect cables if the battery cabinet is attached to the UPS.

EXM46003  
 Rev. 0

**Figure 5 Battery cabinet terminal detail, 1200mm cabinet; 50-250kVA UPS**

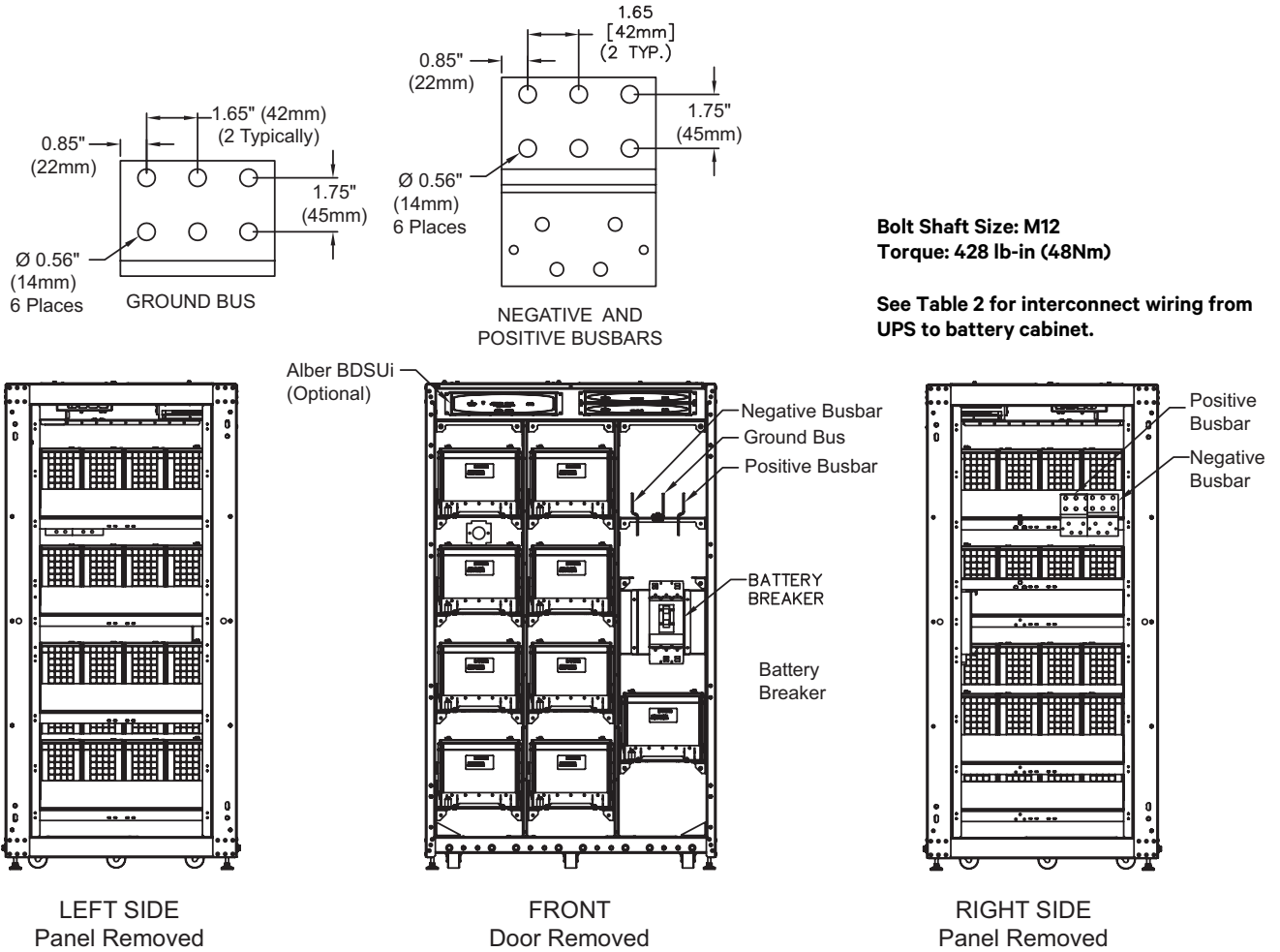

1. Control wiring and power wiring must be run in separate conduits.
2. Vertiv recommends using only copper cables.
3. All wiring must be in accordance with national and local electrical codes.
4. Vertiv will supply the interconnect cables if the battery cabinet is attached to the UPS.

EXM46004  
Rev. 0

**Table 2 Interconnect wiring for UPS to battery cabinet**

Run	From	To	Conductors
A	UPS Battery Busbar	External Battery Cabinet Busbar	Positive, Negative
B	Battery Cabinet Terminal Block TB1	UPS Static Bypass Assembly J22	Battery Breaker Shunt and Aux Contacts

See **Figure 9** for additional details.

Figure 6 Liebert EXM UPS terminal detail 200kVA

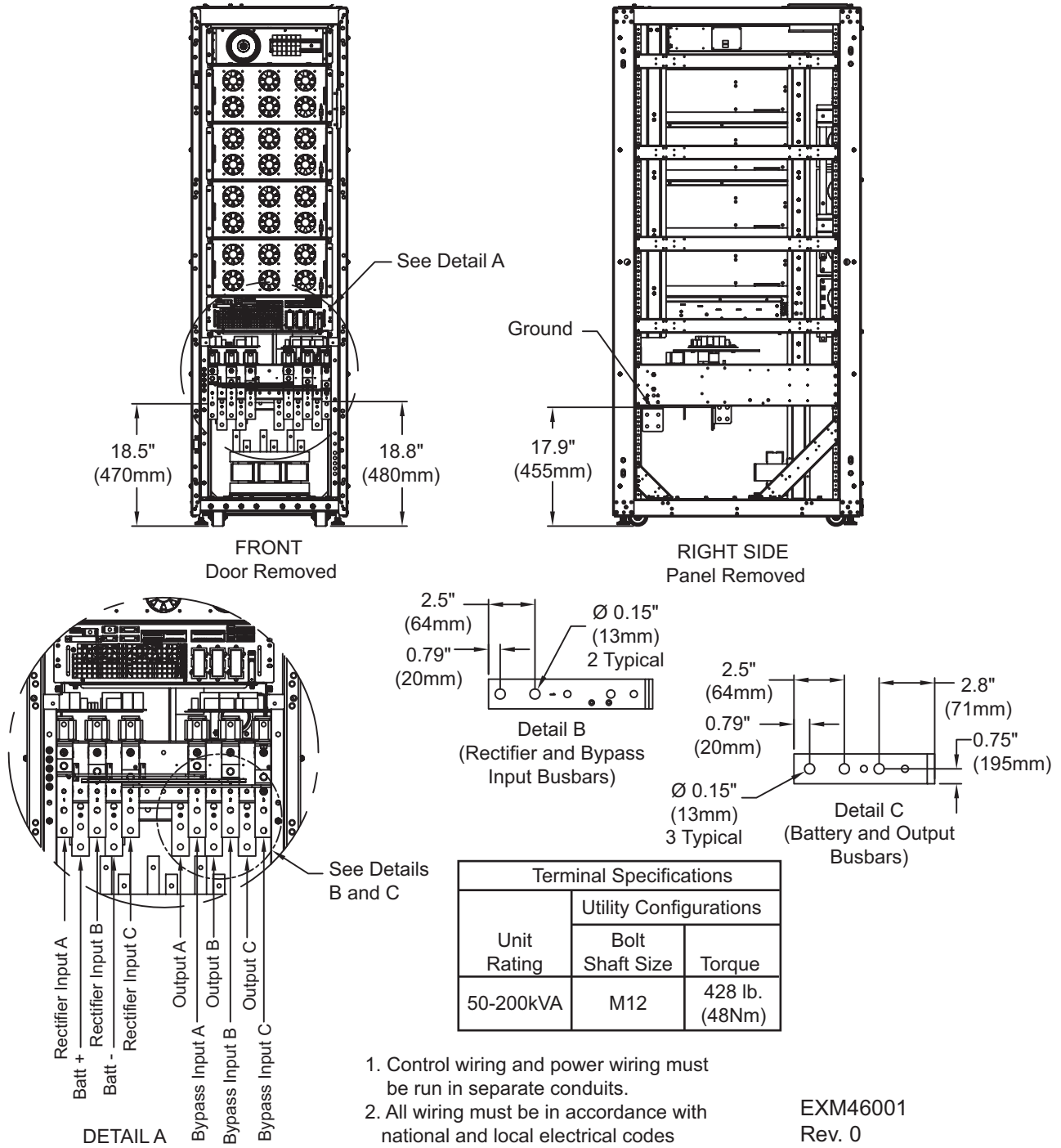

**Figure 7 Liebert EXM UPS terminal detail 250kVA**

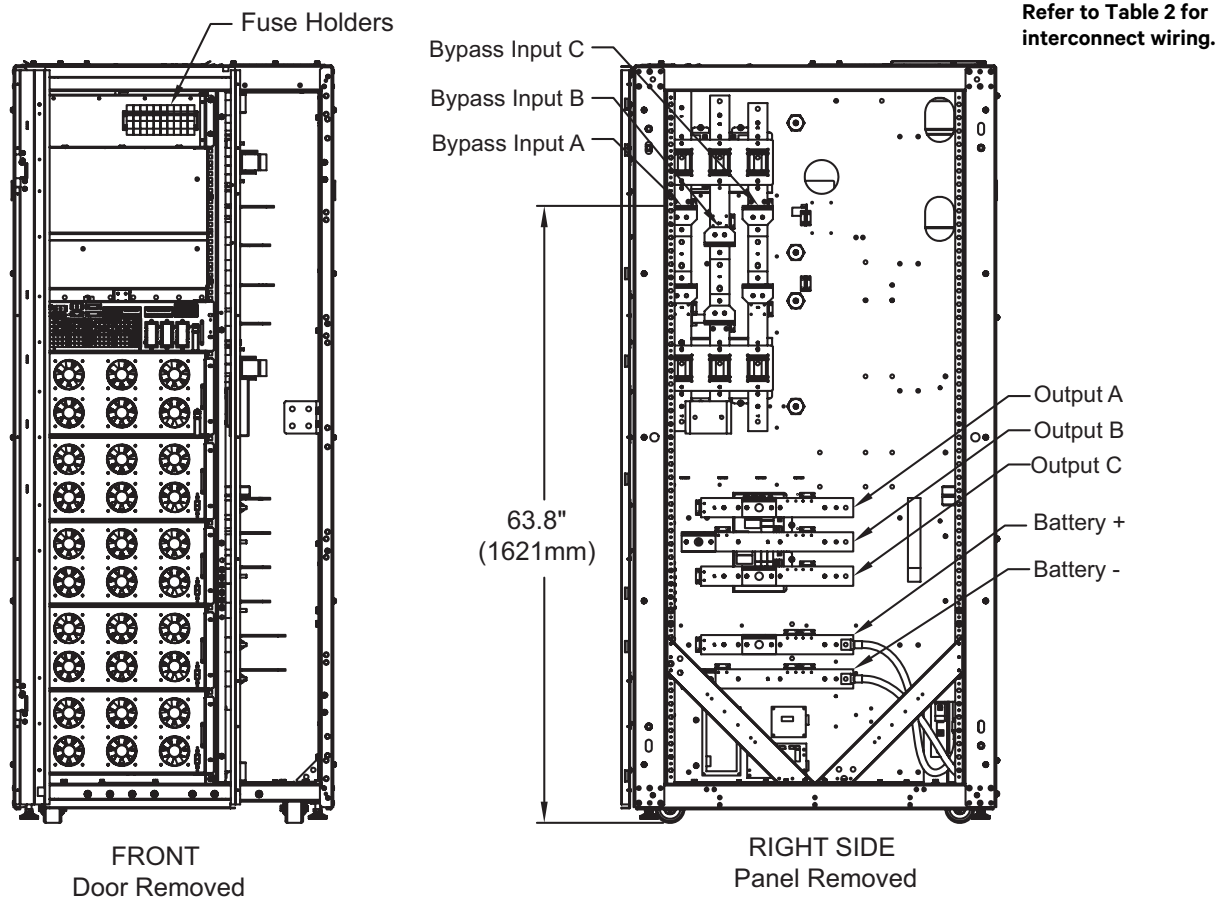

1. Control wiring and power wiring must be run in separate conduits.
2. All wiring must be in accordance with national and local electrical codes

Terminal Specifications		
Unit Rating	Utility Configurations	
	Bolt Shaft Size	Torque
10-40kVA	M10	240 lb.-in. (27Nm)

EXM46002  
Rev. 0

## 2.5 BATTERIES APPROVED FOR USE IN LIEBERT EXM SYSTEMS

**Table 3 Batteries approved for use in Liebert EXM External Battery Cabinet, 880mm**

Supplier	Part Number	Weight, Single Battery, lb. (kg)
EnerSys	12HX150E	26 (11.8)
	12HX205	43 (19.5)
	12HX300-FR	60 (27.2)
East Penn	U1HR1500	27 (12)
	45HR2000	40 (18)
	HR3000	61 (28)
C&D	UPS12-150MR	27.3 (12.4)
	UPS12-210MR	40 (18)
	UPS12-300MR	58.4 (26.5)

**Table 4 Batteries approved for use in Liebert EXM External Battery Cabinet, 1200mm**

Supplier	Part Number	Weight, Single Battery, lb. (kg)
EnerSys	12HX400-FR	80 (36.3)
	12HX505-FR	103 (46.7)
	12HX540-FR	106 (48.1)
East Penn	HR4000	80 (36)
	31HR5000	98 (44)
	HR5500	107 (49)
C&D	UPS12-350MR	67.4 (30.5)
	UPS12-400MR	75.8(34.4)
	UPS12-490MR	100 (45)
	UPS12-540MR	100 (45)

### 2.5.1 Floor Installation

If the Liebert EXM or battery cabinet is to be placed on a raised floor, the UPS should be mounted on a pedestal that will support the equipment point loading. Refer to the bottom view in **Figures 13** or **14** to design this pedestal.

The mechanical stops are used to prevent the cabinet from rolling and should not be used for leveling or bearing the battery cabinet's weight.

### 2.5.2 Cable Entry

Cables can enter the Liebert EXM, Liebert BDC and battery cabinets from the top or bottom through removable metal plates.

Some plates have factory-punched holes and others are designed to allow the personnel to punch holes for fitting and securing the conduit. Once the conduit holes are punched, these plates should be reattached to the UPS. The conduit size and wiring method must be in accordance with all local, regional and national codes and regulations, including NEC ANSI/NFPA 70.

## 2.6 STATIC BYPASS ASSEMBLY

**Figure 8** Static Bypass Assembly connections

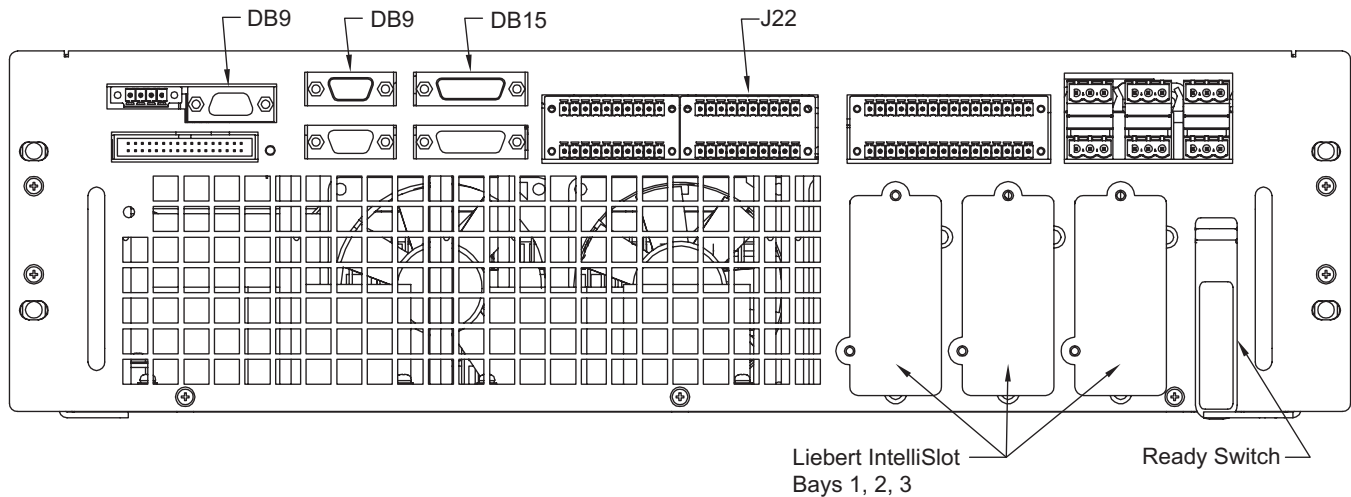

The Static Bypass Assembly has three Liebert IntelliSlot™ interface card bays and connections for ancillary cabinets (Liebert BDC and battery) and for options.

## 2.7 CONTROL WIRING

### 2.7.1 Battery Cabinet Interface Connectors

The battery cabinet interface is on the Auxiliary Terminal Block at J22. Refer to **Figure 9** for circuit details.

**Table 5** Battery cabinet interface—J22

Pin	Name	Description
1	12V_DRV	BCB driver signal
3	BCB_STATUS	BCB state signal
5	GND_DRY	Dry ground
7	BCB_ON	BCB on line signal
9	NC	NC
11	GND_DRY	Dry ground
13	TMP_BATT	External Battery temperature
15	12V_A	Power
17	GND_DRY	Dry ground
19	BATT_GND_FAULT	Battery ground fault signal



### NOTE

All auxiliary cables of terminal must be double-insulated. Wire should be 20-16AWG stranded for maximum runs between 80 and 200 feet (25-60m), respectively.

Figure 9 Single battery cabinet connection to Liebert EXM

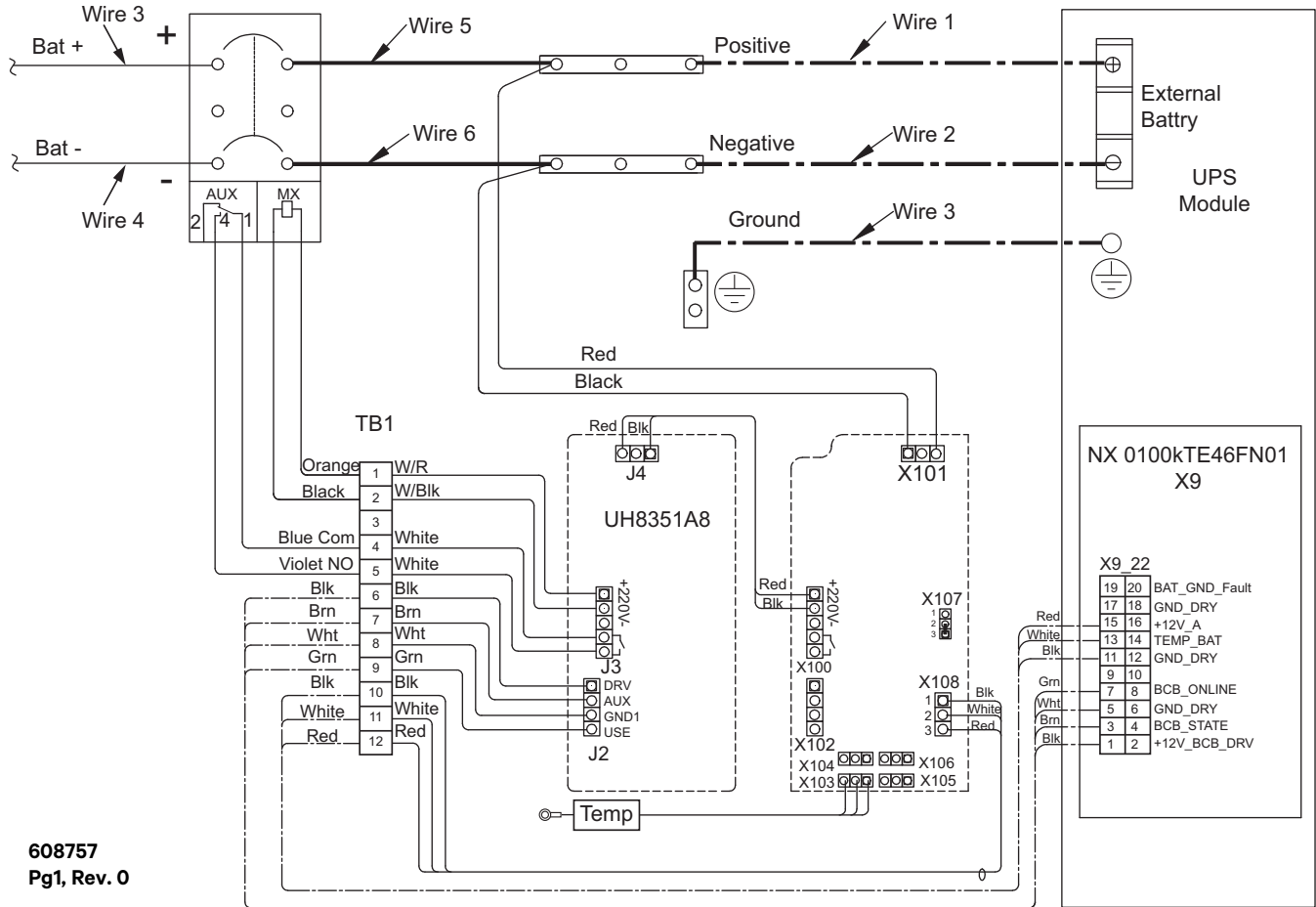

608757  
Pg1, Rev. 0

**Matching Battery Cabinets—Optional**

Although the individual battery cells are sealed (valve-regulated) and require only minimal maintenance, the Battery Cabinets should be given a periodic inspection and electrical check. Checks should be performed at least annually to ensure years of trouble-free service.

Voltage Records: With the Battery Cabinet DC circuit breaker closed and the connected UPS operating, measure and record battery float voltage. With the DC circuit breaker open, measure and record the nominal (open circuit) voltage. Both these measurements should be made across the final positive and negative terminal lugs. Compare these values with those shown below. The recorded nominal voltage should be no less than the value shown; while the recorded float voltage should be within the range shown. If a discrepancy is found, contact Liebert Services.

Table 6 Battery voltage, nominal and float

Number of Cells	Battery Voltage, VDC	
	Nominal/ Open Cell	Float
216	432	486

**Power Connections:** Check for corrosion and connection integrity. Inspect wiring for discolored or cracked insulation. Clean and/or retighten as required. Refer to torque specifications in **Table 17**.

**Battery Cell Terminals:** Check for discoloration, corrosion and connection integrity. Clean and tighten if necessary. Note that when installing a new battery, the initial torque value is 5 lb.-in. more than the retorquer value. **Table 17** shows battery retorquer values. All batteries are supplied with tab washers for easier connection to the Alber BDSUi™ or other monitoring equipment.

If the system uses a different model battery, contact Liebert Services for the required torque value.

To access battery cell terminals, disconnect the inter-tier cable and two shelf retaining screws. Once disconnected, insulate (with protective boot or electrical tape) the cables to prevent accidental shorts. The battery shelf can now be pulled out. Tighten each terminal connection to the retorquer value. When replacing a battery, the terminal connections must be cleaned and tightened. Disconnect and insulate the cables connected to the battery. Secure each battery shelf with retaining screws when maintenance is complete.

## **WARNING**

Risk of heavy unit tipping over while being moved. Can cause property damage, injury and death. The casters are strong enough for movement across even surfaces only. Casters may fail if they are subjected to shock loading, such as being dropped or rolled over holes in the floor or obstructions. Such failure may cause the unit to tip over, injuring personnel and damaging the equipment.

## **AVERTISSEMENT**

Le centre de gravité élevé de l'appareil présente un risque de renversement lors des déplacements, peut entraîner des dommages matériels, des blessures et même la mort.

Les roulettes sont suffisamment résistantes pour le déplacement sur des surfaces planes uniquement. Les roulettes peuvent être endommagées si vous les soumettez à des impacts, notamment en cas de chute ou de passage sur des obstacles ou trous dans le plancher. Une telle défaillance peut causer le renversement de l'appareil, qui risque de blesser le personnel et d'endommager l'équipement.

When replacing batteries, use the same number and type of batteries.

## **WARNING**

Risk of electrical shock. Can cause personal injury and death. Check for voltage with both AC and DC voltmeters before working within the UPS. Check for voltage with both AC and DC voltmeters before making contact. Only properly trained and qualified personnel wearing appropriate safety headgear, gloves, shoes and glasses should be involved in installing the UPS or preparing the UPS for installation. When performing maintenance with any part of the equipment under power, service personnel and test equipment should be standing on rubber mats. Lead-acid batteries contain hazardous materials. Batteries must be handled, transported and recycled or discarded in accordance with federal, state and local regulations. Because lead is a toxic substance, lead-acid batteries must be recycled rather than discarded. Do not dispose of battery or batteries in a fire. The battery may explode. Do not open or mutilate the battery or batteries. Released electrolyte is harmful to the skin and eyes. It is toxic.

The following precautions must be observed when working on batteries:

- Remove watches, rings and other metal objects.
- Use tools with insulated handles.
- Wear rubber gloves and boots.
- Do not lay tools or metal parts on top of batteries.
- Disconnect charging source prior to connecting or disconnecting battery terminals.
- Determine whether the battery is grounded. If it is grounded, remove source of ground.

Contact with any part of a grounded battery can result in electrical shock. The likelihood of such shock will be reduced if such grounds are removed during installation and maintenance.



## AVERTISSEMENT

Risque de décharge électrique pouvant causer des blessures graves, voire mortelles.

Vérifiez les tensions au moyen de voltmètres c.a. et c.c. avant d'utiliser le système ASC. Vérifiez les tensions avec des voltmètres c.a. et c.c. avant d'établir tout contact.

Seuls des employés qualifiés et dûment formés portant un casque, des gants, des chaussures et des lunettes de sécurité adéquats doivent se charger d'installer le système ASC ou de le préparer pour l'installation. Les responsables de l'entretien et l'équipement d'essai doivent reposer sur des tapis de caoutchouc lors de toute intervention sur une pièce d'équipement sous tension.

Les batteries au plomb-acide renferment des matières dangereuses. Les batteries doivent être manipulées, transportées, recyclées ou jetées conformément aux règlements fédéraux, provinciaux et municipaux. Étant donné que le plomb est une substance toxique, les batteries au plomb-acide doivent être recyclées plutôt que mises au rebut.

Ne jetez jamais de batteries au feu car elles risquent d'exploser.

Vous ne devez ni ouvrir ni percer les batteries, car l'électrolyte qui s'en écoulerait est nocif pour la peau et les yeux. Cet électrolyte est toxique.

Lorsque vous travaillez avec des batteries, prenez les précautions suivantes :

- Retirez montre, bagues et tout autre objet métallique.
- Utilisez des outils dont le manche est isolé.
- Portez des gants et des bottes de caoutchouc.
- Ne posez aucun outil ni pièce métallique sur le dessus d'une batterie.
- Déconnectez la source de chargement avant de brancher ou de débrancher les bornes d'une batterie.
- Vérifiez si la batterie est mise à la terre. Le cas échéant, éliminez la cause de la mise à la terre.

Le contact avec toute partie d'une batterie mise à la terre peut provoquer une décharge électrique. Pour réduire de tels risques d'accident, débranchez les prises de terre avant de procéder à l'installation ou à l'entretien.

## 2.8 ALBER® BDSUi™ BATTERY MONITORING SYSTEM—OPTIONAL

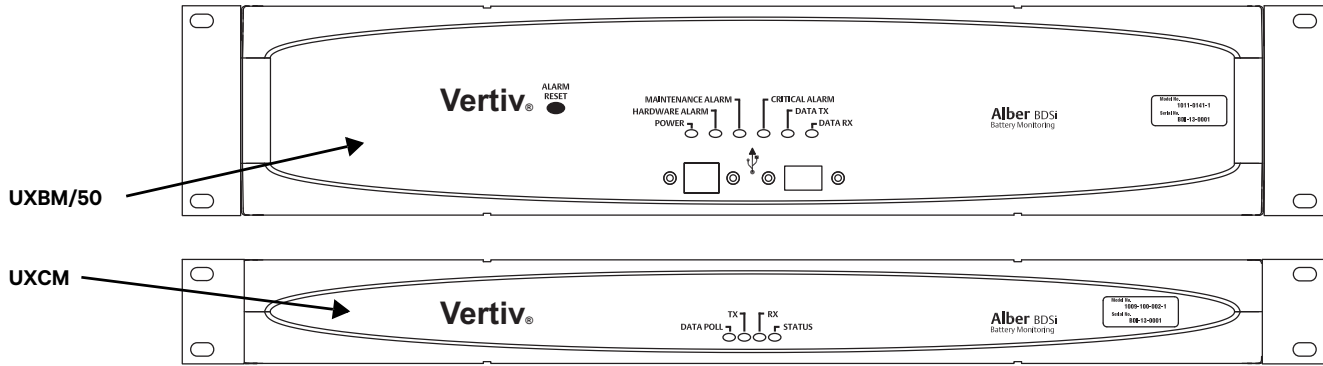

The matching Liebert battery cabinets allow installing an optional Alber BDSUi battery monitoring system inside the cabinet. The Alber BDSUi continuously checks all critical battery parameters, such as cell voltage, overall string voltage, current and temperature. Automatic periodic tests of internal resistance of each battery will verify the battery's operating integrity. Additional capabilities include automatic internal DC resistance tests and trend analysis providing the ability to analyze performance and aid in troubleshooting.

The Alber BDSUi system is installed inside the battery cabinet as shown in **Figures 13** and **14**. The monitoring system power inlet is wired to the Alber BDSUi fuse block on the UPS (see **Figures 10** and **12**). The Alber BDSUi fuse block supplies 120VAC and has an 8A fuse.

If required, power can be supplied from the output terminals of the UPS, a distribution panel or another UPS-protected source.

For details about operating the Alber system, refer to the Alber unit's documentation, available at <http://www.alber.com/>

**Figure 10** Alber BDSUi-UXCM rear panel

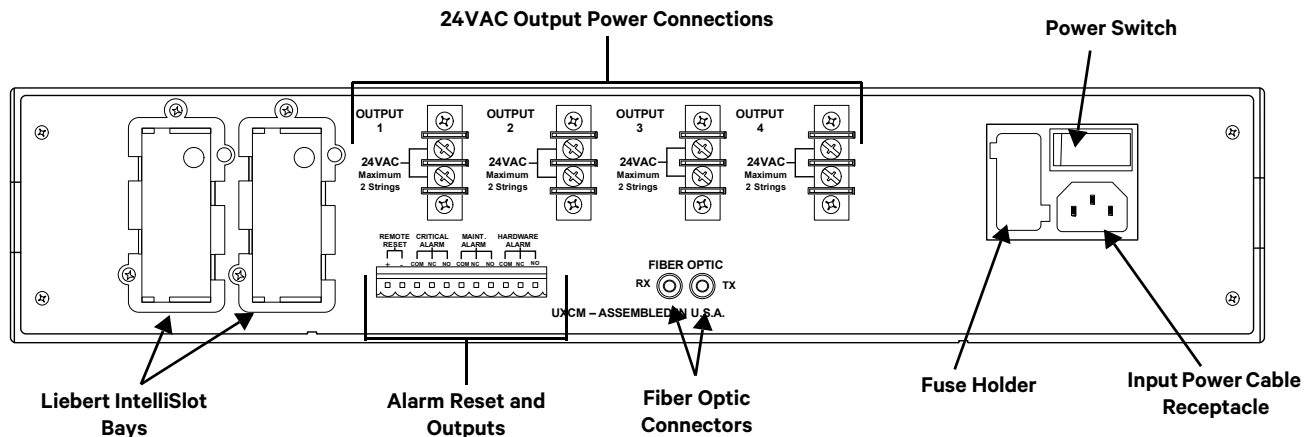

**Table 7** Alber UXCM rear panel features

Connection	Function
Liebert IntelliSlot Bays, 2	Enables remote connectivity and use of optional protocols
Remote Alarm Reset	Permits a remote alarm to be reset by shorting these two pins
Form C Alarm Relay Output	Enables alarm outputs for critical, maintenance and hardware alarms
24VAC Output Power	Power connections for UXBM when a UXCM is connected to multiple strings
Fiber Optic	Communication with the UXBM/50
Power Switch	Turns UXCM On and Off
Input Power Receptacle	Power cord connection and fuse holder

## 2.9 CONNECTING AN ALBER® BDSUI-UXBM/50™

The battery module is wired at the factory. Refer to the Alber user manual for details.

Figure 11 Alber BDSUi-UXBM/50 rear panel

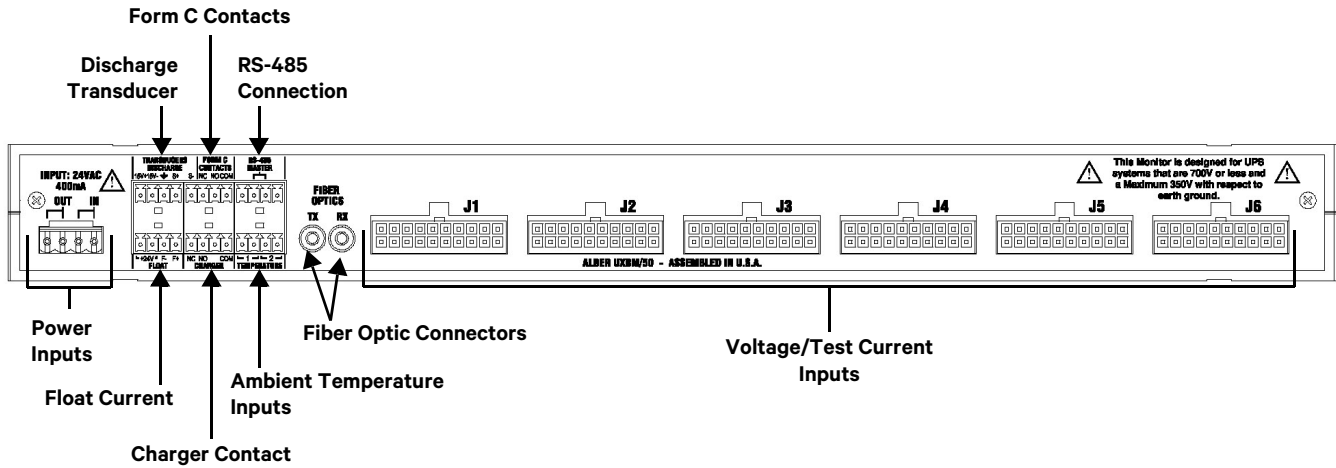
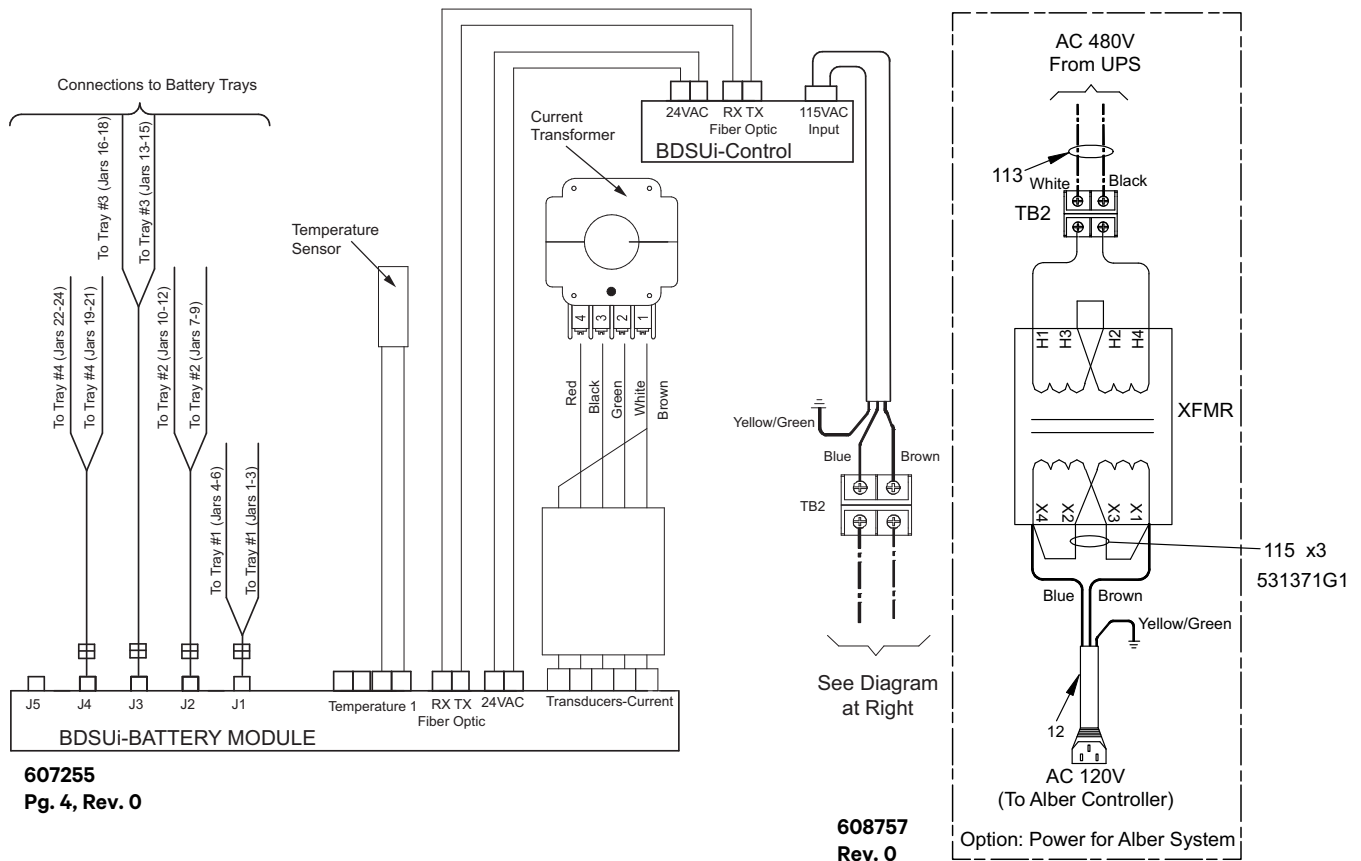

Table 8 Alber UXCM rear panel features

Connection	Function
Power Inputs	Power Input Connections
Discharge Transducer	Discharge Transducer Connection
Float Current	Float Current Transducer Connection
Form C Contacts	Spare Form C Contacts
Charger Contact	Charger contact for charger control connection. Charger control relay output for thermal runaway management. (Automatically shuts down charger when thermal runaway is detected.)
RS-485 Connection	Communication with optional accessories
Fiber Optic Connectors	Communication with the BDSU network
Voltage/Test Current Inputs	Sense lead connections for making voltage/test current measurements

**Figure 12 Alber® battery cabinet monitoring assembly diagram**



## 2.9.1 Accessory Fuses and Back-Feed Breaker Wiring

Two fuse blocks provide power for the back-feed breakers (standard) and the Alber BDSUi™ (optional). The fuse blocks are at the lower right of the I/O panel on the front of the Liebert EXM UPS.

The back-feed breaker fuse block provides 120V nominal provided from the UPS output (L-N) and the fuse is rated for 8 amps. The back-feed breaker wiring is on the bypass static switch assembly.

The Liebert EXM UPS does not include internal back-feed protection. A shunt trip coil of 120V must be installed in the bypass input breaker if the system does not include a Liebert Bypass Cabinet. This is a safety feature and will prevent the UPS inverter from back-feeding the bypass source.

The Alber BDSUi fuse block provides 208V nominal from the UPS output (L-N) and the fuse is rated at 8A. See **Figure 12** for the Alber BDSUi power wiring.

## 2.10 BATTERY PROTECTION

### 2.10.1 Battery Low-Voltage Warning

Before the end of discharge, the Liebert EXM displays a low battery warning. After this warning, the battery has the capacity for 5 minutes discharging with full load (default time). The Liebert EXM can be user-configured to display this warning from 3 to 60 minutes before end-of-discharge.

### 2.10.2 Battery End-of-Discharge (EOD) Protection

If the battery voltage is lower than the end-of-discharge voltage, the battery converter will be shut down.

# 3.0 INSTALLATION DRAWINGS

Figure 13 Battery cabinet outline drawing and main components—880mm cabinet

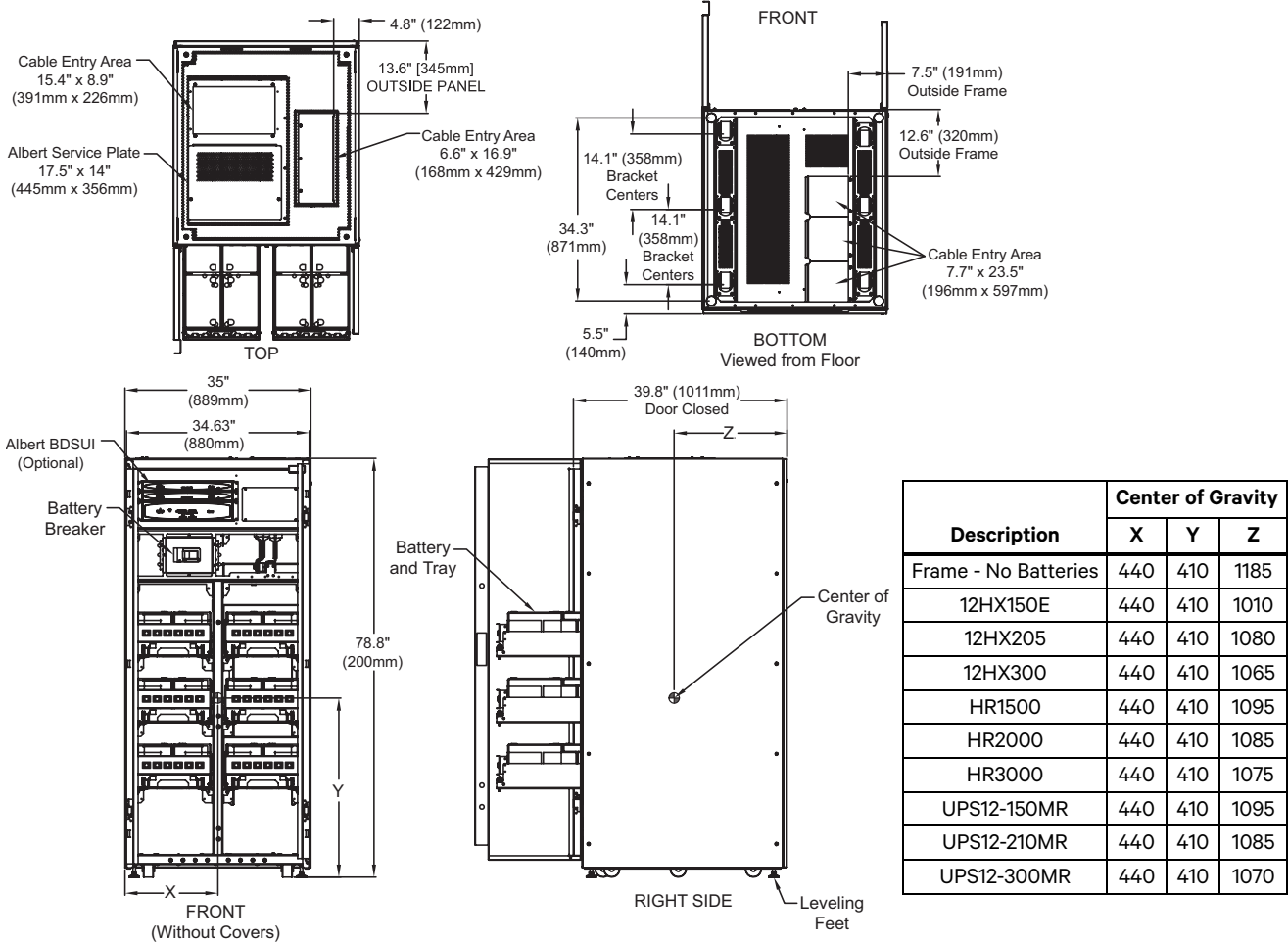

- 24" (610mm) minimum clearance above unit for air exhaust.  
36" (914mm) front access required for service.
- Keep cabinet within 15 degrees of vertical.
- Top and bottom cable entry available through removable access plates. Remove, punch to suit conduit size and replace.
- Control wiring and power wiring must be run in separate conduits.
- Copper cables only are recommended.
- All wiring must be in accordance with national and local electrical codes.

EXM42003  
Pg. 1, Rev. 0

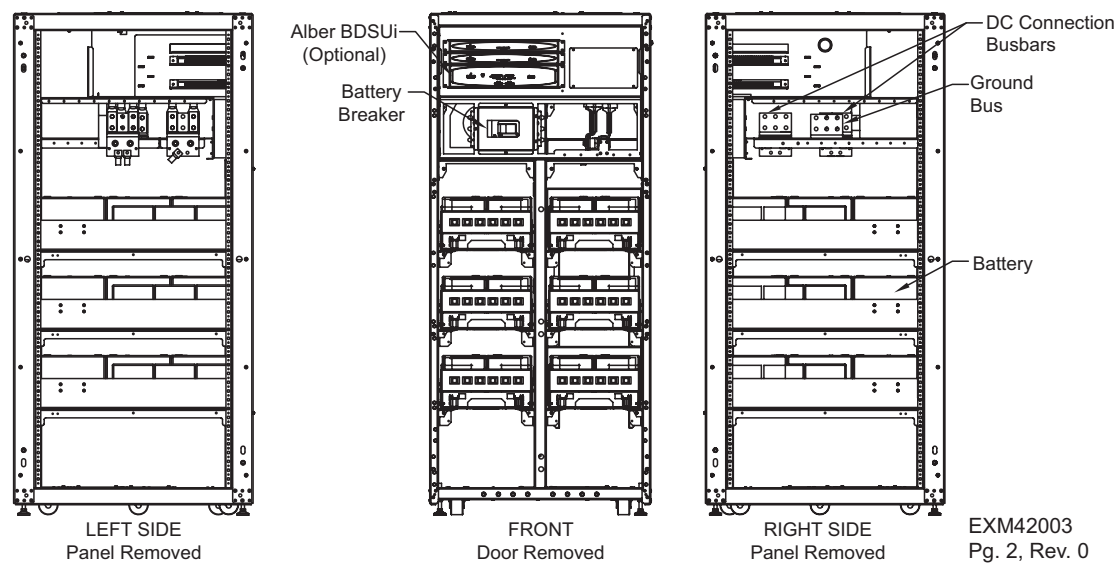

EXM42003  
Pg. 2, Rev. 0

**Figure 14 Battery cabinet outline and main components—1200mm cabinet**

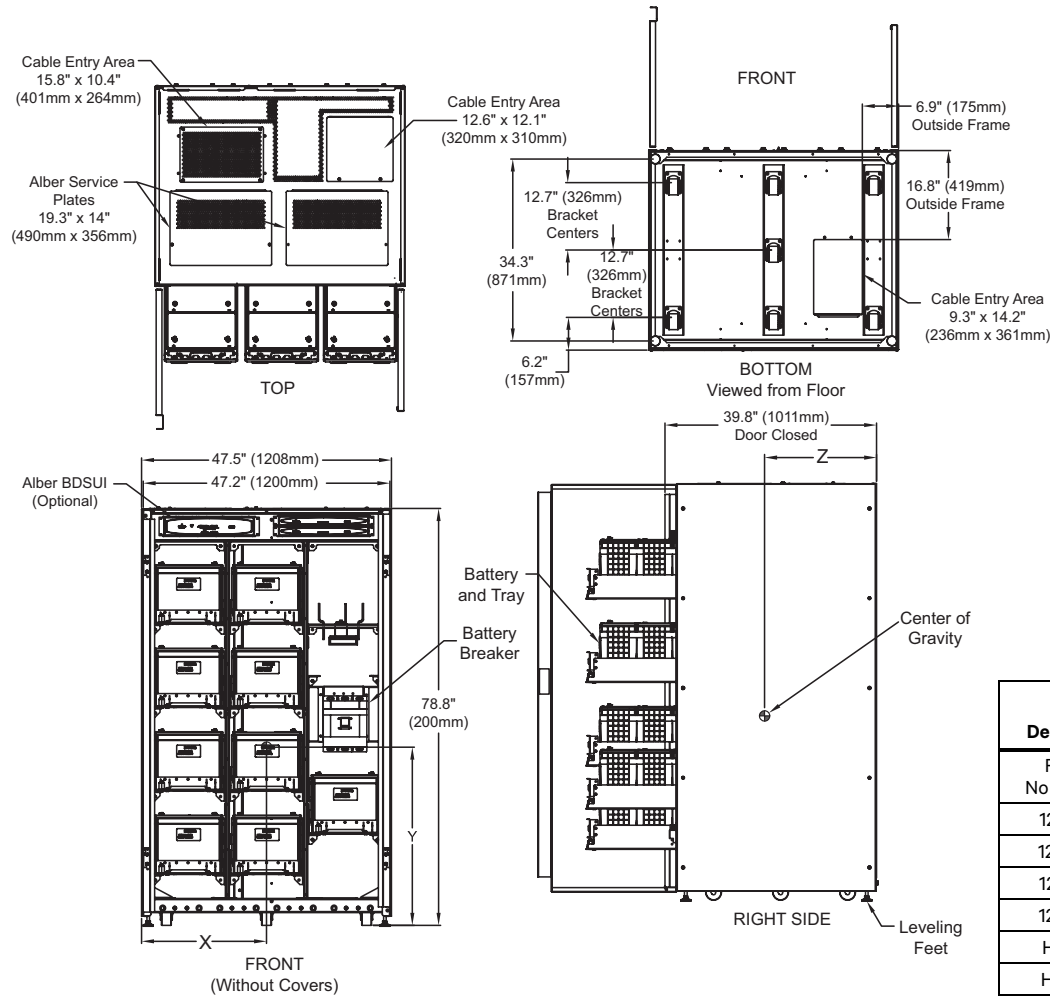

Description	Center of Gravity		
	X	Y	Z
Frame - No Batteries	495	504	1175
12HX330	495	504	945
12HX400	495	504	930
12HX505	495	504	915
12HX540	495	504	894
HR3500	495	504	950
HR4000	495	504	935
HR5000	495	504	918
HR5500	495	504	892
UPS12-350MR	495	504	950
UPS12-400MR	495	504	935
UPS12-490MR	495	504	898
UPS12-540MR	495	504	898

- 24" (610mm) minimum clearance above unit for air exhaust.  
36" (914mm) front access required for service.
  - Keep cabinet within 15 degrees of vertical.
  - Top and bottom cable entry available through removable access plates. Remove, punch to suit conduit size and replace.
  - Control wiring and power wiring must be run in separate conduits.
  - Copper cables only are recommended.
  - All wiring must be in accordance with national and local electrical codes.
- EXM42004 Pg. 1, Rev. 0

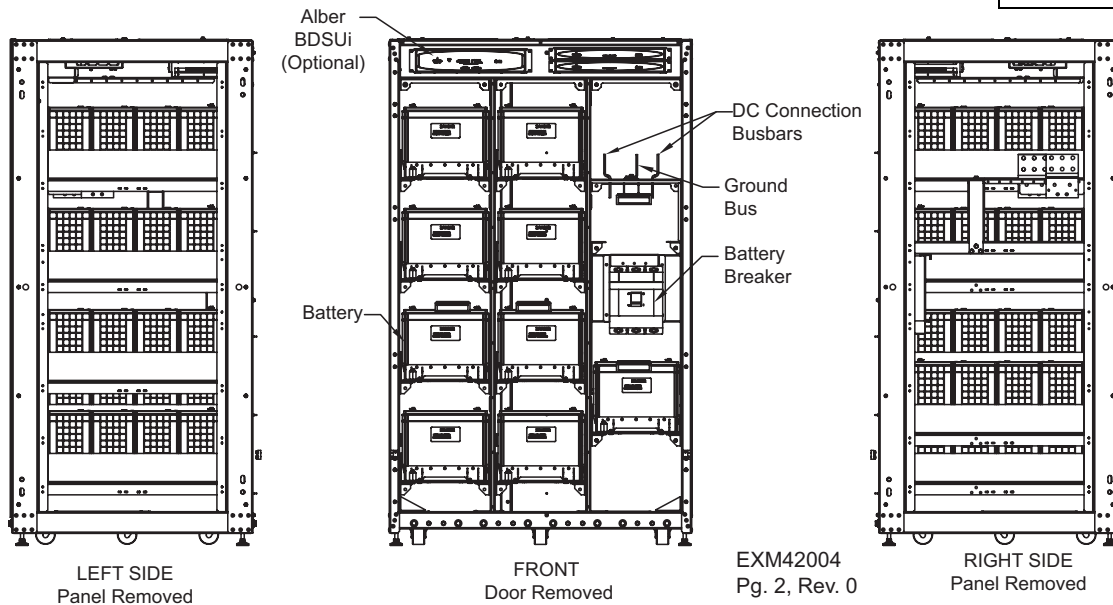

# 4.0 SPECIFICATIONS

**Table 9 Physical standards and parameters**

Battery Cabinet Parameters	Values
Standard Color	Black (ZP-7021)
Front Door Opening (for serviceability)	180°
Degree of Protection for UPS Enclosure	IP 20 (with and without front door open)
Minimum Clearance, Top	24" (610mm)
Minimum Clearance, Back	0"
Minimum Clearance, Sides	0"
Cable Entrance	Top or Bottom
<b>Standards &amp; Conformities</b>	UL 1778 5th Ed.; CSA 22.2 107.3-14 FCC Part 15, Class A; ISTA Procedure 1H; WEEE; IBC 2012/CBC 2013
<b>Environmental</b>	
Storage Temperature Range, °F (°C)	-13°F to 158°F (-25°C to 70°C) 74°F to 80°F (23-27°C) for optimal battery life
Operating Temperature Range, °F (°C)	32°F to 104°F (0 to 40°C) 74°F to 80°F (23-27°C) for optimal battery life
Relative Humidity	up to 95% Non-Condensing (Operating and Non-Operating)
Maximum Altitude Above MSL, ft (m)	4920 (1500) (as per IEC 62040/3) - 1% Maximum kW derate / 100m rise between 1500-3000m

**Table 10 Battery cabinet system—UPS and Liebert EXM Battery Cabinet**

UPS Rating kVA	Battery Cabinet Breaker	Maximum Battery Current, A	Battery Cabinet Size, mm	Copper Wire	Compression Lug	Bolt Size
50-100	300A	290	880, 1200	(2) 3/0	54874BE (2 Hole)	1/2"
150	450A	435	880, 1200	(2) 250kcmil	54874BE (2 Hole)	1/2"
200	600A	581	880, 1200	(3) 250kcmil	54874BE (2 Hole)	1/2"
250 *	600A	581	880, 1200	(3) 250kcmil	54874BE (2 Hole)	1/2"

\* 250kVA UPS requires a minimum of two cabinets.

**Table 11 Battery short circuit currents**

Supplier	Part #	Short Circuit Current, A
EnerSys	12HX150E-FR	1890
	12HX205-FR	2775
	12HX300-FR	3175
	12HX330-FR	3700
	12HX400-FR	4225
	12HX505-FR	4510
	12HX540-FR	4775
East Penn	U1HR1500	1861
	45HR2000	1940
	HR3000	4228
	HR3500	4604
	HR4000	5429
	31HR5000	3987
	HR5500	5145
C&D	UPS12-150MR	2500
	UPS12-210MR	3000
	UPS12-300MR	3600
	UPS12-350MR	4200
	UPS12-400MR	5100
	UPS12-490MR	5000
	UPS12-540MR	5000

**Table 12 Battery DC intermediate circuit**

Parameter	50 - 250kVA
Battery Bus Voltage	432
Number of Lead-Acid Cells	216 = (36 x 6 cell [12V] blocks), nominal
Float Voltage	2.25V/cell, selectable from 2.2 - 2.3V/cell
Temperature Compensation	-3.0mV/°C, selectable from 0 to -5.0mV/°C around 77°F (25°C) or 86°F (30°C) or inhibit
Ripple Voltage	≤1%
Ripple Current	≤5%
Boost Charge Voltage	2.35 V/cell (selectable from 2.30-2.40V/cell)
Boost Control	<ul style="list-style-type: none"> <li>• Float-boost current trigger 0.050 C10 (selectable 0.030-0.070)</li> <li>• Boost-float current trigger 0.010 C10 (selectable 0.005-0.025)</li> <li>24 hr safety time-out (selectable 8-30 hr)</li> <li>Boost charge mode inhibit also selectable</li> </ul>
End of Discharge	1.67 V/cell (selectable from 1.67-1.750V/cell)
Battery Charge Operation	Constant current and constant voltage charge mode Programmable auto trigger or inhibit of boost mode
Battery Charging Power Maximum Current	UPS, kVA: 50, 100, 150, 200, 250 Battery Charging Power: 5.5kW per 50kVA power module Maximum Charging Current, A: 10A per 50kVA power module



**Table 13 880mm battery cabinet mechanical characteristics**

Rated Power, kVA	50-250kVA
Dimensions, W x D x H, in (mm)	34.645 x 39.375 x 78.75 (880 x 1000 x 2000)
<b>Weight, lb (kg)</b>	
With HX150 Batteries	1738 (788)
With HX205 Batteries	2350 (1066)
With HX300 Batteries	2962 (1344)
With U1HR1500	1744 (805)
With 45HR2000	2242 (1017)
With HR3000	2818 (1278)
With UPS12-150MR	1785 (810)
With UPS12-210MR	2242 (1017)
With USP12-300MR	2904 (1317)
<b>Color</b>	ZP-7021 (Black)
<b>Protection Degree IEC (60529)</b>	IP20 (finger-proof with front doors open or closed)

**Table 14 1200mm battery cabinet mechanical characteristics**

Rated Power, kVA	50-250kVA
Dimensions, W x D x H, in (mm)	34.645 x 39.375 x 78.75 (1200 x 1000 x 2000)
<b>Weight, lb (kg)</b>	
With HX330 Batteries	3647 (1654)
With HX400 Batteries	3971 (1801)
With HX505 Batteries	4799 (2177)
With HX540 Batteries	4907 (2226)
With HR3500	3467 (1573)
With HR4000	3755 (1703)
With 31HR5000	4620 (2096)
With HR5500	4943 (2242)
With UPS12-350MR	3517 (1595)
With UPS12-400MR	3820 (1733)
With USP12-490MR	4691 (2128)
With UPS12-540MR	4691 (2128)
<b>Color</b>	ZP-7021 (Black)
<b>Protection Degree IEC (60529)</b>	IP20 (finger-proof with front doors open or closed)

**Figure 15 Battery, circuit breaker and UPS wiring with external batteries with two connecting wires**

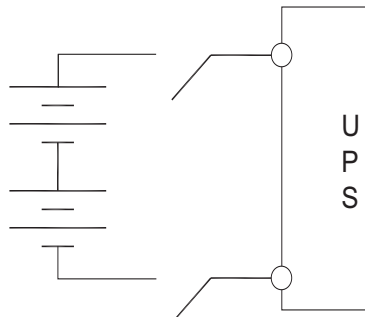

## 5.0 MAINTENANCE

Become thoroughly familiar with the equipment, but at no time go beyond the specific procedures in this manual while performing maintenance or correcting a malfunction. If you have any doubt as to what must be done, call Vertiv Liebert Services at 1-800-LIEBERT for further instructions. The UPS is designed for unattended operation, but does require some common sense maintenance.

- Keep good records—Troubleshooting is easier if you maintain historical service records.
- Keep the UPS free of dust and any moisture.
- Keep the UPS cool:
  - Battery systems must be kept in the range of 72-77°F (22-25°C) in order to meet design specifications for capacity and longevity.
  - The UPS will reliably meet all performance specifications at temperatures up to 104°F (40°C), and can be slightly derated for operation at even higher temperatures. However, performance and longevity will be optimized when the UPS is operated at the same temperature as the batteries.
- Keep connections tight.
- Tighten all connections at installation and at least annually thereafter. (See **5.4 - Torque Requirements**).

### 5.1 RECORD LOG

Set up a maintenance log to record scheduled checks and any abnormal conditions.

The log should have space for all metered data including phase readings, alarm messages, UPS mode of operation, air filter replacement date and observation notes. A second log should be maintained for the battery module as directed by the battery manufacturer.

Vertiv recommends a periodic walk-through inspection of the UPS and battery rooms to check for visible and audible indications of problems. Log the inspection, metered parameter indications and any discrepancies.

### 5.2 BATTERY MAINTENANCE

#### **WARNING**

Risk of electrical shock and arc flash. Can cause property damage, injury and death.

These maintenance procedures will expose hazardous live parts. Refer servicing to properly trained and qualified personnel.

#### **AVERTISSEMENT**

Risque d'arc ou de décharge électrique pouvant entraîner des dommages matériels, des blessures et même la mort.

Les procédures d'entretien ci-dessous exposent des composants sous tension dangereuse. Les interventions d'entretien doivent être confiées à du personnel qualifié et dûment formé.

### 5.3 BATTERY SAFETY PRECAUTIONS

Servicing of batteries should be performed or supervised by personnel experienced with batteries and the required precautions. Keep unauthorized personnel away from batteries.

When replacing batteries, use the same number and type of batteries.

## **WARNING**

Risk of electrical shock. Can cause personal injury and death.

Check for voltage with both AC and DC voltmeters before working within the UPS. Check for voltage with both AC and DC voltmeters before making contact.

Only properly trained and qualified personnel wearing appropriate safety headgear, gloves, shoes and glasses should be involved in installing the UPS or preparing the UPS for installation. When performing maintenance with any part of the equipment under power, service personnel and test equipment should be standing on rubber mats.

Lead-acid batteries contain hazardous materials. Batteries must be handled, transported and recycled or discarded in accordance with federal, state and local regulations. Because lead is a toxic substance, lead-acid batteries must be recycled rather than discarded.

Do not dispose of battery or batteries in a fire. The battery may explode.

Do not open or mutilate the battery or batteries. Released electrolyte is harmful to the skin and eyes. It is toxic.

The following precautions must be observed when working on batteries:

- Remove watches, rings and other metal objects.
- Use tools with insulated handles.
- Wear rubber gloves and boots.
- Do not lay tools or metal parts on top of batteries.
- Disconnect charging source prior to connecting or disconnecting battery terminals.
- Determine whether the battery is grounded. If it is grounded, remove source of ground. Contact with any part of a grounded battery can result in electrical shock. The likelihood of such shock will be reduced if such grounds are removed during installation and maintenance.

## **AVERTISSEMENT**

Risque de décharge électrique pouvant causer des blessures graves, voire mortelles.

Vérifiez les tensions au moyen de voltmètres c.a. et c.c. avant d'utiliser le système ASC. Vérifiez les tensions avec des voltmètres c.a. et c.c. avant d'établir tout contact.

Seuls des employés qualifiés et dûment formés portant un casque, des gants, des chaussures et des lunettes de sécurité adéquats doivent se charger d'installer le système ASC ou de le préparer pour l'installation. Les responsables de l'entretien et l'équipement d'essai doivent reposer sur des tapis de caoutchouc lors de toute intervention sur une pièce d'équipement sous tension.

Les batteries au plomb-acide renferment des matières dangereuses. Les batteries doivent être manipulées, transportées, recyclées ou jetées conformément aux règlements fédéraux, provinciaux et municipaux. Étant donné que le plomb est une substance toxique, les batteries au plomb-acide doivent être recyclées plutôt que mises au rebut.

Ne jetez jamais de batteries au feu car elles risquent d'exploser.

Vous ne devez ni ouvrir ni percer les batteries, car l'électrolyte qui s'en écroulerait est nocif pour la peau et les yeux. Cet électrolyte est toxique.

Lorsque vous travaillez avec des batteries, prenez les précautions suivantes :

- Retirez montre, bagues et tout autre objet métallique.
- Utilisez des outils dont le manche est isolé.
- Portez des gants et des bottes de caoutchouc.
- Ne posez aucun outil ni pièce métallique sur le dessus d'une batterie.
- Déconnectez la source de chargement avant de brancher ou de débrancher les bornes d'une batterie.
- Vérifiez si la batterie est mise à la terre. Le cas échéant, éliminez la cause de la mise à la terre. Le contact avec toute partie d'une batterie mise à la terre peut provoquer une décharge électrique. Pour réduire de tels risques d'accident, débranchez les prises de terre avant de procéder à l'installation ou à l'entretien.

Regular maintenance of the battery module is an absolute necessity. Periodic inspections of battery and terminal voltages, specific gravity, and connection resistance should be made. Strictly follow the procedures outlined in the battery manufacturer's manual. (See battery manufacturer's web site.)

Valve-regulated lead-acid batteries do require periodic maintenance. Although they do not require maintenance of electrolyte levels, visual inspections and checks of battery voltage and connection resistance should be made.

### NOTICE

Risk of damaging battery cases. Can cause breakage and leaking electrolyte.

Do not use cleaners on the batteries. Solvents can make the battery cases brittle. Use only a dry cloth or a cloth moistened with water.

Since individual battery characteristics are not identical and may change over time, the UPS module is equipped with circuitry to equalize battery cell voltages. This circuit temporarily increases charging voltage to maintain flooded type battery cells at full capacity.

### WARNING

Risk of electric shock, explosive reaction, hazardous chemicals and fire. Can cause equipment damage, personal injury and death.

Do not use equalize charging with valve-regulated, lead-acid batteries, such as those used in Liebert battery cabinets. Refer to the battery manufacturer's manual, available on the manufacturer's Web site, for specific information about equalize charging.

### AVERTISSEMENT

Risque de décharge électrique, de réaction explosive, d'incendie et d'exposition à des produits chimiques dangereux pouvant entraîner des dommages matériels, des blessures et même la mort.

N'utilisez pas de charge d'égalisation avec des batteries d'accumulateurs au plomb à régulation par soupape, comme celles utilisées dans les armoires de batterie Liebert. Reportez-vous au manuel du fabricant des batteries, disponible sur le site Web du fabricant, pour obtenir des renseignements précis sur la charge d'égalisation.

## 5.4 TORQUE REQUIREMENTS

All electrical connections must be tight.

**Tables 15** through **17** provide the torque values for the connections in the UPS and batteries. Use these values unless the equipment is labeled otherwise.

**Table 15 Busbars (for power wiring)**

Bolt Shaft Size	Lb-in	Nm
3/8" (M10)	192	22
1/2" (M12)	428	48

**Table 16 Terminal block with compression lugs (for control wiring)**

AWG Wire Size or Range	Lb-in	Nm
#22 - #14	3.5 to 5.3	0.4 to 0.6

**Table 17 Battery retorque values**

Battery Mfr.	Battery Model #	Retorque Value in-lb. (Nm)
EnerSys	12 HX100-FR	40 (4.5)
	12 HX150E-FR	40 (4.5)
	12 HX205-FR	65 (7.3)
	12 HX300-FR	65 (7.3)
	12 HX330-FR	65 (7.3)
	12 HX400-FR	65 (7.3)
	12 HX500-FR	65 (7.3)
	12 HX540-FR	65 (7.3)
East Penn	U1HR1500	45 (5.1)
	45HR2000	100 (11.3)
	HR3000	100 (11.3)
	HR3500	100 (11.3)
	HR4000	100 (11.3)
	31HR5000	100 (11.3)
	HR5500	100 (11.3)
C&D	UPS12-150MR	30 (3.4)
	UPS12-210MR	30 (3.4)
	USP12-300MR	110 (12.4)
	UPS12-350MR	110 (12.4)
	UPS12-400MR	110 (12.4)
	USP12-490MR	110 (12.4)
	UPS12-540MR	110 (12.4)



## **TECHNICAL SUPPORT / SERVICE**

### **Web Site**

[www.vertivco.com](http://www.vertivco.com)

### **Monitoring**

[liebert.monitoring@vertivco.com](mailto:liebert.monitoring@vertivco.com)

800-222-5877

Outside North America: +00800 1155 4499

### **Three-Phase UPS & Power Systems**

800-543-2378

Outside North America: 614-841-6598

## **LOCATIONS**

### **United States**

1050 Dearborn Drive

P.O. Box 29186

Columbus, OH 43229

### **Europe**

Via Leonardo Da Vinci 8

Zona Industriale Tognana

35028 Piove Di Sacco (PD) Italy

+39 049 9719 111

Fax: +39 049 5841 257

### **Asia**

29/F, The Orient Square Building

F. Ortigas Jr. Road, Ortigas Center

Pasig City 1605

Philippines

+63 2 687 6615

Fax: +63 2 730 9572

---



**VertivCo.com | Vertiv Headquarters**, 1050 Dearborn Drive, Columbus, OH, 43085, USA

© 2016 Vertiv Co. All rights reserved. Vertiv and the Vertiv logo are trademarks or registered trademarks of Vertiv Co. All other names and logos referred to are trade names, trademarks or registered trademarks of their respective owners. While every precaution has been taken to ensure accuracy and completeness herein, Vertiv Co. assumes no responsibility, and disclaims all liability, for damages resulting from use of this information or for any errors or omissions. Specifications are subject to change without notice.

SL-25656\_REV2\_12-16