

FRONT VIEW

EXTERNAL BATTERY
CABINET DETECTION
TERMINALS

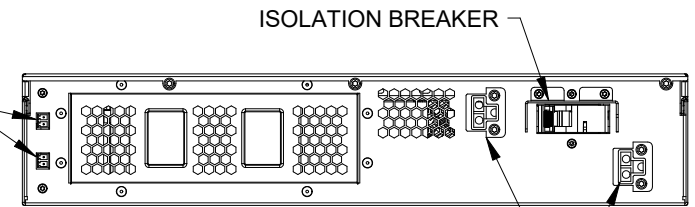

EXTERNAL BATTERY
CONNECTOR

REAR VIEW

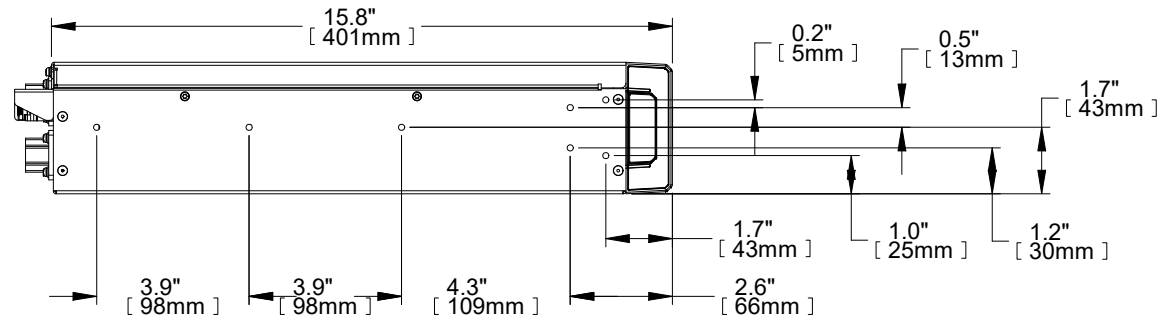

SIDE VIEW

NOTES:

1. UNIT DIMENSIONS (WxDxH): 16.9" x 15.8" x 3.3" (2U)
(430mm) x (401mm) x (85mm)
2. UNIT WEIGHT: 49.72lbs (22.6kg)
3. SHIPPING DIMENSIONS (WxDxH): 22.4" x 24.3" x 10.3"
(570mm) x (617mm) x (262mm)
4. SHIPPING WEIGHT: 63.14lbs (28.7kg)
5. MINIMUM AIRFLOW CLEARANCE IS 4.0" (100mm)
FRONT AND REAR.

DRAWN BY B. LAY	SHEET NO. 1 OF 1
CHK BY M. MCCLINCY	ECN NO.
REF. DWG.	ORDER NO.

OUTLINE DRAWING
LIEBERT GXT5
36V EXTERNAL BATTERY CABINET

DWG. NO. GXT5-36VEBC_OD	DATE 1/30/19	REV. # 0	1050 DEARBORN DRIVE P.O. BOX 29186 COLUMBUS, OHIO 43229
----------------------------	-----------------	-------------	---

