



Liebert[®] MCV

Installer/User Guide

60 Hz and 50 Hz, High Density Microchannel Condenser

The information contained in this document is subject to change without notice and may not be suitable for all applications. While every precaution has been taken to ensure the accuracy and completeness of this document, Vertiv assumes no responsibility and disclaims all liability for damages resulting from use of this information or for any errors or omissions.

Refer to local regulations and building codes relating to the application, installation, and operation of this product. The consulting engineer, installer and/or end user is responsible for compliance with all applicable laws and regulations relating to the application, installation, and operation of this product.

The products covered by this instruction manual are manufactured and/or sold by Vertiv. This document is the property of Vertiv and contains confidential and proprietary information owned by Vertiv. Any copying, use or disclosure of it without the written permission of Vertiv is strictly prohibited.

Names of companies and products are trademarks or registered trademarks of the respective companies. Any questions regarding usage of trademark names should be directed to the original manufacturer.

Technical Support Site

If you encounter any installation or operational issues with your product, check the pertinent section of this manual to see if the issue can be resolved by following outlined procedures.

Visit <https://www.vertiv.com/en-us/support/> for additional assistance.

TABLE OF CONTENTS

1 Important Safety Instructions	1
2 Nomenclature and Components	5
2.1 Vertiv™ Liebert® MCV Model Number Nomenclature	5
2.2 Component Location	6
2.3 Product Description and Features	7
2.3.1 Control, Fan Types, and Features	7
3 Pre-installation Preparation and Guidelines	9
3.1 Planning Dimensions	10
3.2 Unit Weights	10
4 Equipment Inspection and Handling	11
4.1 Packaging Material	11
4.2 Lift Points for Moving the Skid	11
4.3 Removing Shipping Panels and Brackets	12
5 Piping	13
5.1 Refrigerant Piping and Charging	14
5.1.1 Refrigerant Piping Guidelines for Air Cooled Systems	14
5.1.2 Refrigerant Charge Requirements	16
5.1.3 Additional Oil Requirements	16
5.2 System Dehydration/Leak Test	16
5.3 Charging for Condensers	16
6 Electrical Connections	17
6.1 Line Voltage Wiring	18
6.2 Wye vs. Delta Connected Power Supply for EC Fans	20
6.3 Wye vs. Delta Connected Power Supply for Alternative EC Fans	20
6.4 Low Voltage Control Wiring—CANbus Communication	21
7 Checklist for Completed Installation	23
7.1 Moving and Placing Equipment	23
7.2 Electrical Installation Checks	23
7.3 Piping Installation Checks	23
7.4 Other Installation Checks	23
8 Initial Start-up Checks and Commissioning Procedure for Warranty Inspection	25
9 Troubleshooting	27
10 Control Operation	29
10.1 Vertiv™ Liebert® EconoPhase Pumped Refrigerant Economizer with a Vertiv™ Liebert® DSE System	29
10.2 Overview of Operating Modes	30
10.3 Vertiv™ Liebert® EconoPhase Operation	32
10.3.1 Vertiv™ Liebert® EconoPhase Control	33

- 10.3.2 Pump Start-up Routine 35
- 10.3.3 Switch from Compressor Operation to Pump Operation 35
- 10.3.4 Switch from Pump Operation to Compressor Operation 35
- 10.4 Premium Efficiency Control Board and Interface 36
 - 10.4.1 Initial Display upon Power On 37
 - 10.4.2 Navigating the Controller Interface Main Menu 37
 - 10.4.3 Analog Signals Menu 38
 - 10.4.4 Active Alarms Menu 41
 - 10.4.5 History Alarms Menu 41
- 11 Maintenance 47**
- 11.1 General Maintenance 48
- 11.2 Condenser Cleaning - Standard Coil 48
 - 11.2.1 When to Clean the Condenser Coil 48
 - 11.2.2 What to Use to Clean the Condenser Coil 48
 - 11.2.3 Cleaning the Condenser Coil 49
- 11.3 Condenser Cleaning - E-coat Coil 49
 - 11.3.1 General Instructions: (detailed instructions to follow) 49
 - 11.3.2 Detailed Instructions 51
- 11.4 Replacing the Condenser EC Fan 53
 - 11.4.1 Fan Replacement 54
 - 11.4.2 P--Menu Programming 54
 - 11.4.3 Manual Fan Addressing (No P-- Menu) 55
 - 11.4.4 Verifying the Fan Address 57
- 11.5 Replacing the Premium Efficiency Control Board 58
 - 11.5.1 Preparing to Replace the Board 58
 - 11.5.2 Installing the Replacement Board 59
- 12 Preventive Maintenance Checklist 61**
- Appendices 65**
- Appendix A: Technical Support and Contacts 65
- Appendix B: Submittal Drawings 67

1 Important Safety Instructions

SAVE THESE INSTRUCTIONS

This manual contains important safety instructions that should be followed during the installation and maintenance of the Vertiv™ Liebert® MCV. Read this manual thoroughly before attempting to install or operate this unit.

Only qualified personnel should move, install or service this equipment.

Adhere to all warnings, cautions, notices and installation, operating, and safety instructions on the unit and in this manual. Follow all installation, operation, and maintenance instructions and all applicable national and local building, electrical, and plumbing codes.



WARNING! Arc flash and electric shock hazard. Open all local and remote electric power supply disconnect switches, verify with a voltmeter that power is Off and wear appropriate, OSHA-approved personal protective equipment (PPE) per NFPA 70E before working within the electric control enclosure. Failure to comply can cause serious injury or death. Customer must provide earth ground to unit, per NEC, CEC, and local codes, as applicable. Before proceeding with installation, read all instructions, verify that all the parts are included, and check the nameplate to be sure the voltage matches available utility power. The Vertiv™ Liebert® iCOM™ controller does not isolate power from the unit, even in the Unit Off mode. Some internal components require and receive power even during the Unit Off mode of the Liebert® iCOM™ controller. The only way to ensure that there is NO voltage inside the unit is to install and open a remote disconnect switch. Refer to unit electrical schematic. Follow all local codes.



WARNING! Risk of electric shock. Can cause equipment damage, injury or death. Open all local and remote electric power supply disconnect switches and verify with a voltmeter that power is off before working within any electric connection enclosures. Service and maintenance work must be performed only by properly trained and qualified personnel and in accordance with applicable regulations and manufacturers' specifications. Opening or removing the covers to any equipment may expose personnel to lethal voltages within the unit even when it is apparently not operating and the input wiring is disconnected from the electrical source.



WARNING! Risk of electric shock. Can cause serious injury or death. The Liebert® iCOM™ microprocessor does not isolate power from the unit, even in the Unit Off mode. Some internal components require and receive power even during the "unit off" mode of the Liebert® iCOM™ control. Open all local and remote electric power disconnect switches and verify with a voltmeter that power is Off before working on any component of the system.



WARNING! Risk of electric shock. Can cause serious injury or death. Open all local and remote electric power supply disconnect switches and verify with a voltmeter that power is off before working within the fan motor electric connection enclosures. Fan motor controls can maintain an electric charge for 10 minutes after power is disconnected. Wait 10 minutes after power is verified as off before working within the fan electric control/connection enclosures. Use only fully trained and qualified HVAC technicians to perform maintenance on the fans.



WARNING! Risk of over pressurization of the refrigeration system. Can cause explosive discharge of high pressure refrigerant, loss of refrigerant, environmental pollution, equipment damage, injury, or death. This unit contains fluids and gases under high pressure. Use extreme caution when charging the refrigerant system. Do not pressurize the system higher than the design pressure marked on the unit's nameplate.



WARNING! Risk of contact with high speed rotating fan blades. Can cause serious injury or death. Open all local and remote electric power supply disconnect switches, verify with a voltmeter that power is off, and verify that all fan blades have stopped rotating before working in the unit cabinet or on the fan assembly. If control voltage is applied, the fan motor can restart without warning after a power failure. Do not operate the unit with any or all cabinet panels removed.



WARNING! Risk of improper wiring, piping, moving, lifting and handling. Can cause equipment damage, serious injury or death. Installation and service of this equipment should be done only by qualified personnel who have been specially trained in the installation of air conditioning equipment and who are wearing appropriate, OSHA-approved PPE.



WARNING! Risk of improper moving, lifting, or handling of the unit. Can cause equipment damage, injury or death. Read all of the following instructions and verify that all lifting and moving equipment is rated for the weight of the unit before attempting to move, lift, remove packaging from or prepare the unit for installation. See **Table 3.2** on page 10, for weights.



WARNING! Risk of improper wire sizing/rating and loose electrical connections. Can cause overheated wire and electrical connection terminals resulting in smoke, fire, equipment and building damage, injury or death. Use correctly sized copper wire only and verify that all electrical connections are tight before turning power On. Check all electrical connections periodically and tighten as necessary.



WARNING! Risk of electrical fire and short circuit. Can cause property damage, injury or death. Select and install the line side electrical supply wire and overcurrent protection device(s) according to the specifications on the unit nameplate(s), per the instructions in this manual and according to the applicable national, state and local code requirements. Use copper conductors only. Verify that all electrical connections are tight. Unit specific wiring diagrams are provided on each unit.



CAUTION: Risk of improper moving, lifting and handling. Can cause equipment damage or injury. Only properly trained and qualified personnel should work on this equipment. Condenser fan modules weigh in excess of 115 lb (52.2 kg). Use proper lifting techniques and wear appropriate, OSHA-approved PPE to avoid injury and dropping the fan module during removal. Equipment used in handling/lifting, and/or installing the fan assembly must meet OSHA requirements. Use handling/lifting equipment rated for the weight of the fan assembly. Use ladders rated for the weight of the fan assembly and technicians if used during installation. Refer to handling/lifting, and/or installation equipment operating manual for manufacturer's safety requirements and operating procedures.



CAUTION: Risk of contact with sharp edges, splinters, and exposed fasteners. Can cause injury. Only properly trained and qualified personnel wearing appropriate, OSHA-approved PPE should attempt to move, lift, remove packaging from or prepare the unit for installation.



CAUTION: Risk of contact with hot surfaces. Can cause injury. The electronics housing, humidifier components, compressor, refrigerant discharge lines, fan motor, and some electrical components are extremely hot during unit operation. Allow sufficient time for them to cool to a touch safe temperature before working within the unit cabinet. Use extreme caution and wear appropriate, OSHA-approved PPE when working on or near hot components.



CAUTION: Risk of exposure to harmful noise levels. Can cause hearing injury or loss. Depending on the installation and operating conditions, a sound pressure level greater than 70 dB(A) may arise. Take appropriate technical safety measures. Operating personnel must wear appropriate, OSHA-approved PPE and observe all appropriate hearing-protection safety requirements.

NOTICE

Risk of improper power supply connection. Can cause equipment damage and loss of warranty coverage.

Prior to connecting any equipment to a main or alternate power source (for example: backup generator systems) for start up, commissioning, testing, or normal operation, ensure that these sources are correctly adjusted to the nameplate voltage and frequency of all equipment to be connected. In general, power source voltages should be stabilized and regulated to within $\pm 10\%$ of the load nameplate nominal voltage. Also, ensure that no three phase sources are single phased at any time.

NOTICE

Risk of oil contamination with water. Can cause equipment damage.

Liebert® MCV systems require the use of POE (polyolester) oil. POE oil absorbs water at a much faster rate when exposed to air than previously used oils. Because water is the enemy of a reliable refrigeration system, extreme care must be used when opening systems during installation or service. If water is absorbed into the POE oil, it will not be easily removed and will not be removed through the normal evacuation process. If the oil is too wet, it may require an oil change. POE oils also have a property that makes them act as a solvent in a refrigeration system. Maintaining system cleanliness is extremely important because the oil will tend to bring any foreign matter back to the compressor.

NOTICE

Risk of control malfunction. Can cause improper unit operation.

Verify that all low voltage electrical wiring has been performed per the schematic diagram provided and that all low voltage wiring connections are tight.

This page intentionally left blank

2 Nomenclature and Components

This section describes the model number for Vertiv™ Liebert® MCV units and components.

2.1 Vertiv™ Liebert® MCV Model Number Nomenclature

Table 2.2 below describes each digit of the 25-digit configuration number. The 14-digit model number consists of the first 10 digits and last four digits of the configuration number.

Table 2.1 Liebert® MCV 25-Digit Configuration Number Example

Model # Part 1										Model Details										Model # Part 2				
1	2	3	4	5	6	7	8	9	10	11	12	13	14	15	16	17	18	19	20	21	22	23	24	25
M	C	V	3	3	0	E	2	A	D	0	G	0	0	U	0	2	0	0	0	0	*	*	*	*

Table 2.2 Liebert® MCV Model Number Digit Definitions

Digit	Description
Digits 1 and 2 = Unit Family	MC = Microchannel Condenser
Digit 3 Platform Size	V = V-coil arrangement
Digits 4-6 - Nominal Capacity, kW	330 = 330 kW 440 = 440 kW
Digit 7 - Control/Fan Type	E = Premium control and EC fan
Digit 8 - Refrigerant Circuits/System Refrigerant Type	2 = Dual refrigerant circuit, R-410A
Digit 9 - Power Supply	A = 460V/3ph/60Hz 2 = 380V/3ph/60Hz M = 380-415V/3ph/50Hz
Digit 10 - Packaging	D = Domestic, non-stackable E = Export crating, non-stackable
Digit 11 - Coil Coating	0 = None C = E-coat (epoxy with UV topcoat)

Table 2.2 Liebert® MCV Model Number Digit Definitions (continued)

Digit	Description
Digit 12 - Panel Material	G = Galvanized steel
Digit 13 - Connection Pipe Unit of Measurement	0 = Inches (std. ACR copper)
Digit 14 - Legs Included	0 = No legs (standard)
Digit 15 - Agency Certification	U = CSA listed, marked with CSA c-us logo
Digit 16 - Undefined, Reserved for future use.	
Digit 17 - Receiver/Software Configuration	0 = Liebert® DSE software, no receivers 2 = Liebert® DSE software, with receivers
Digits 18-21 - Undefined, Reserved for future use.	
Digits 22-25 - Factory configuration number	

2.2 Component Location

The unit component locations are described in the submittal documents included in [Submittal Drawings](#).

The following table lists the relevant documents by number and title.

Table 2.3 Heat Rejection Skid Component Location Drawings

Document Number	Title
DPN003888	Component Location Diagram, MCV330 + EconoPhase + Base Assembly
DPN003872	Component Location Diagram MCV330 (2) + EconoPhase (2) + Base Assembly
DPN00425	Component Location Diagram MCV440 + EconoPhase + Base Assembly
DPN004260	Component Location Diagram MCV440 (2) + EconoPhase + Base Assembly

2.3 Product Description and Features

The Vertiv™ Liebert® MCV condenser is a direct drive EC fan type, air cooled heat rejection unit suitable for mounting outdoors. It provides heat rejection for two separate refrigeration circuits, matches the heat rejection capacity corresponding with the outdoor ambient temperature and with each corresponding compressor heat rejection requirements. Constructed with a galvanized steel frame, galvanized steel panels, and aluminum microchannel coil, the unit is quiet and corrosion resistant. The condenser is quickly and easily installed, because all internal wiring is completed at the factory with only electrical connections to be made at the job site. All electrical connections and controls are enclosed in an integral, weatherproof section of the condenser.

Figure 2.1 Liebert® MCV Heat Rejection Skid

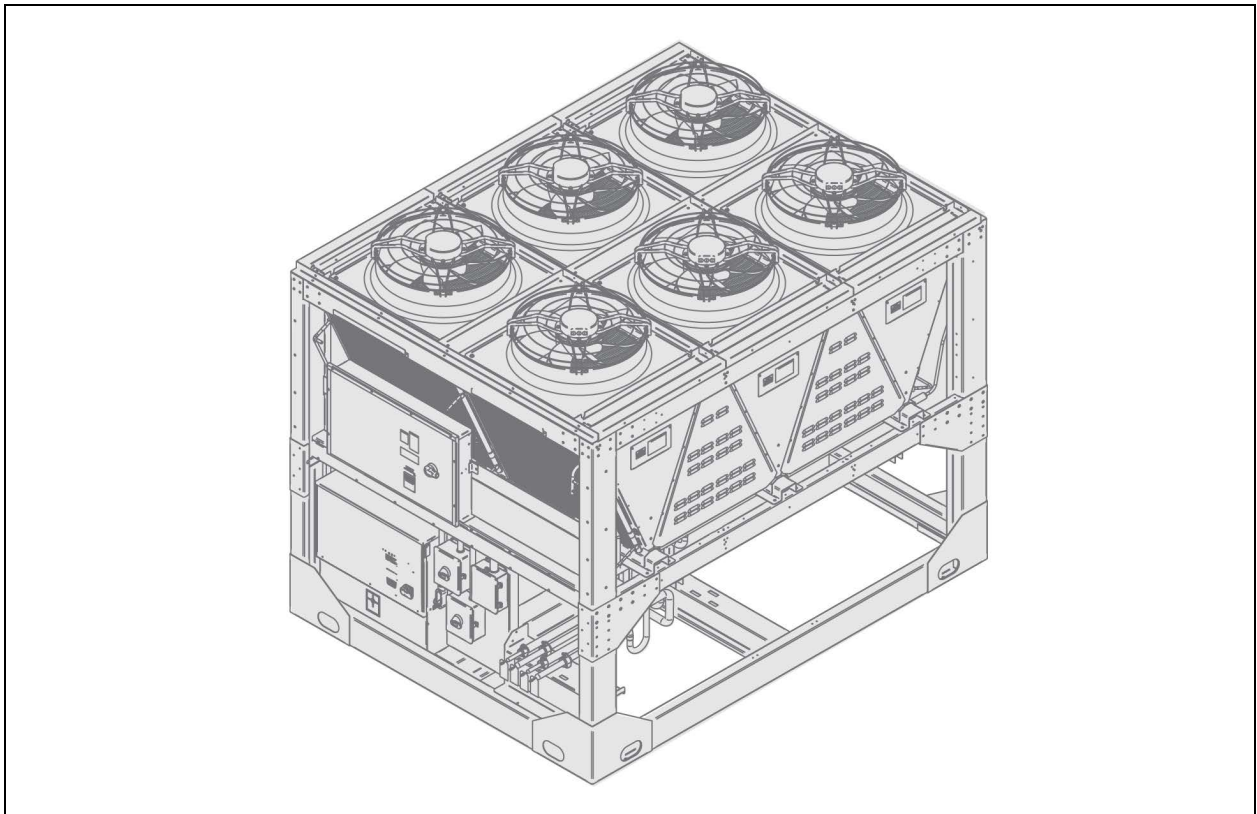

2.3.1 Control, Fan Types, and Features

Premium Efficiency Control/EC Fan

Premium Efficiency Controls and EC fans are matched to provide superior system energy efficiency. The premium control board allows CANbus communication with the indoor unit's Vertiv™ Liebert® iCOM™ control. This communication feature provides compressor run signals, condenser operating mode changes, condenser alarm monitoring, simplified system charging procedures, and outdoor temperature monitoring.

The Premium Efficiency Control board on a Vertiv™ Liebert® MCV controls EC fans on the same circuit to the same speed to maintain refrigerant head pressure in DX mode and refrigerant temperature in EconoPhase mode.

Anti-Freezing Operation

The EC fans must be operated periodically in cold weather to reduce the possibility of lock up due to ice and snow accumulation. During periods of fan inactivity and outdoor temperatures below 35°F (1.6°C), the EC fans will spin for at least 30 seconds every 15 minutes at 60% of the maximum fan speed.

Surge Protective Device

An optional Surge Protective Device (SPD) can be field wired to protect the condenser from power surges that threaten sensitive equipment. The condenser's electrical panel provides a terminal block to allow the SPD to be wired in parallel with the high voltage power. An additional low voltage terminal block is provided on condensers to allow monitoring of the SPD alarm circuit.

ASCO Series 420 surge protective device provides 50 kA per mode of surge current protection. An illuminated green LED indicates the SPD is on and operating properly. An illuminated red LED indicates that the device may require replacement.

When both LEDs are off, there is no power to the condenser, either from a power failure or because the condenser disconnect is in the off position.

3 Pre-installation Preparation and Guidelines

The unit dimensions, pipe connection locations, and piping schematics are described in the submittal documents included in the [Submittal Drawings](#) on page 67.

- Install the condenser in a location offering maximum security and access for maintenance.
- Avoid ground level sites with public access and areas prone to heavy snow or ice accumulations.
- To ensure adequate air supply, we recommend that condensers be installed in an area with clean air, away from loose dirt and foreign matter that might clog the coil. In addition, condensers should be located no closer than 3 ft. (1 m) from a wall, obstruction or adjacent unit.
- For roof installation, mount the condenser on suitable curbs or other supports in accordance with local codes.
- Locations that require additional coil-corrosion protection, such as coastal regions, heavy industrial, or agricultural air pollution, should specify coils with the optional epoxy e-coat.
- Condensers must not be installed in a pit.
- Condensers must be installed on a level surface to ensure proper refrigerant flow.
- The Vertiv™ Liebert® MCV heat rejection skid cannot be installed below the evaporator.
- The DA125 through DA250 are used with a Liebert® MCV heat rejection skid with receiver tanks. For this system, the outlet of the receivers on the outdoor Liebert® MCV heat rejection skid must be higher than the elevation of the electronic (EEV) valves inside of the indoor unit. If the vertical height of the receiver outlet is greater than 60 ft. (18.3m) above the EEV, consult the factory. Refer to DPN003965 in [Submittal Drawings](#) on page 67.
- The DA265 and XDM200/400 is used with a Liebert® MCV heat rejection skid without receiver tanks. For these systems, the bottom of the condenser coil on the outdoor Liebert® MCV heat rejection skid must be higher than the elevation of the EEVs inside of the indoor unit. If the vertical height between the condenser coil bottom and the EEV is greater than 60 ft. (18.3m), consult the factory. For DA265 applications refer to DPN005207 in [Submittal Drawings](#) on page 67. For XDM200/400 applications refer to DPN005138 in [Submittal Drawings](#) on page 67.
- Condensers must be installed in vertical airflow orientation to maintain the NEMA 3R rating of the electrical box.

3.1 Planning Dimensions

The condenser dimensions are described in the submittal documents included in the [Submittal Drawings](#) on page 67. Condensers mounted above and below the relative elevation of the indoor unit must follow the guidelines found in the submittal drawings listed in the table below.

The following table lists the relevant documents by number and title.

Table 3.1 Dimension Planning Drawings

Document Number	Title
Heat Rejection Skid Dimensions	
DPN003889	Cabinet and Anchor Dimensional Data Liebert® MCV330 + Liebert® EconoPhase + Base Assembly
DPN003875	Cabinet and Anchor Dimensional Data Liebert® MCV330 (2) + Liebert® EconoPhase (2) + Base Assembly
DPN004259	Cabinet and Anchor Dimensional Data Liebert® MCV440 + Liebert® EconoPhase + Base Assembly
DPN004261	Cabinet and Anchor Dimensional Data Liebert® MCV440 (2) + Liebert® EconoPhase (2) + Base Assembly
Condenser Elevation Above/Below Unit	
DPN003965	Air Cooled Piping Schematic Liebert® MCV Mounted Above Liebert® DA125-D250
DPN005207	Air Cooled Piping Schematic Liebert® MCV Mounted Above Liebert® DA265
DPN005138, page 1	Air Cooled piping schematic Liebert® MCV mounted above Liebert® XDM
DPN005138, page 2	Air Cooled piping schematic Liebert® MCV mounted below Liebert® XDM

3.2 Unit Weights

Table 3.2 Vertiv™ Liebert® MCV Heat Rejection Skid with Vertiv™ Liebert® EconoPhase Approximate Weights

Model	Number of Fans on Heat Rejection Skid	Number of MCV/PRE Pairs on Heat Rejection Skid	Domestic Shipping Weight lb (kg)	Dry Weight, lb (kg)
MCV330 + PRE with Receiver	6	1	5,000 (2,268)	4,980 (2,258)
MCV330 + PRE with Receiver	12	2	10,000 (4,535)	9,980 (4,526)
MCV440 + PRE with Receiver	8	1	5,900 (2,676)	5,880 (2,667)
MCV440 + PRE with Receiver	16	2	11,580 (5,252)	11,560 (5,243)
MCV440 + PRE without Receiver	8	1	5,800 (2,676)	5,780 (2,621)
MCV440 + PRE without Receiver	16	2	11,380 (5,152)	11,360 (5,152)

4 Equipment Inspection and Handling



WARNING! Risk of improper moving, lifting, or handling of the unit. Can cause equipment damage, injury or death. Read all of the following instructions and verify that all lifting and moving equipment is rated for the weight of the unit before attempting to move, lift, remove packaging from or prepare the unit for installation. See **Table 3.2** on page 10.



CAUTION: Risk of contact with sharp edges, splinters, and exposed fasteners. Can cause injury. Only properly trained and qualified personnel wearing appropriate, OSHA-approved PPE should attempt to move, lift, remove packaging from or prepare the unit for installation.

NOTICE

Risk of improper lifting. Can cause equipment damage. Make sure that the spreader bars are wider than the unit. If the spreader bars are too short, the slings may crush the unit.

NOTICE

Risk of damage from forklift. Can cause unit damage. Keep tines of the forklift level and at a height suitable to fit below the skid and/or unit to prevent exterior and/or underside damage.

NOTICE

Risk of improper storage. Keep the unit upright, indoors and protected from dampness, freezing temperatures and contact damage.

Upon arrival of the unit and before unpacking:

- Verify that the labeled equipment matches the bill of lading.
- Carefully inspect all items for visible or concealed damage.
- Report damage immediately to the carrier and file a damage claim with a copy sent to Vertiv or to your sales representative.

4.1 Packaging Material



All material used to package this unit is recyclable. Please save for future use or dispose of the material appropriately.

4.2 Lift Points for Moving the Skid

Refer to the appropriate submittal drawings to locate the lift points for your heat rejection skid located in the [Submittal Drawings](#).

- Use the indicated lifting points to lift the unit.
- Use spreader bars and/or shimmed blocks to prevent external damage.
- Lift the unit level. Tilting or twisting can damage internal components.
- Use the proper rigging equipment and make sure that attachment and lifting at the designated points is vertical.

The following table lists the submittal documents by title and number.

Table 4.1 Heat Rejection Skid Drawings

Document Number	Title
DPN003882	Cabinet Lifting Points Liebert® MCV330 + Liebert® EconoPhase + Base Assembly
DPN003883	Cabinet Lifting Points Liebert® MCV330 (2) + Liebert® EconoPhase (2) + Base Assembly
DPN004256	Cabinet Lifting Points Liebert® MCV440 + Liebert® EconoPhase + Base Assembly
DPN004263	Cabinet Lifting Points Liebert® MCV440 (2) + Liebert® EconoPhase (2) + Base Assembly

4.3 Removing Shipping Panels and Brackets

Shipping panels and securing brackets are located on each end of the unit. Before operating the unit, remove the panels and brackets from both ends of the unit, see **Figure 4.1** below.

Figure 4.1 Shipping Panels and Securing Brackets to Remove

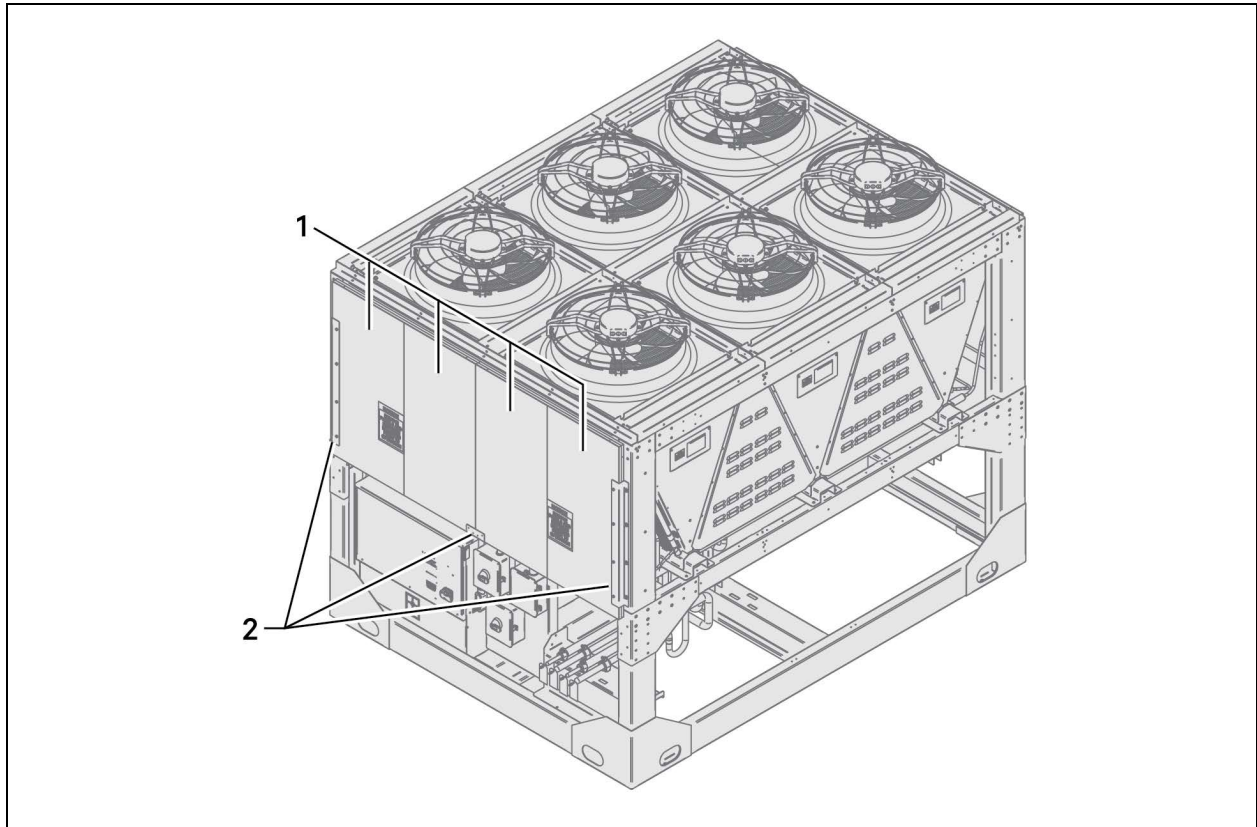

Item	Description
1	4 panels on each end, 8 total
2	3 brackets on each end, 6 total

5 Piping

All refrigeration connections to the unit are sweat copper. Factory installed piping brackets must not be removed. Field installed piping must be installed in accordance with local codes and must be properly assembled, supported, isolated, and insulated.

Refer to specific text and to the submittal documents included in [Submittal Drawings](#), for other unit specific piping requirements.

The following tables list the relevant documents by number and title.

Table 5.1 Piping General Arrangement Drawings

Document Number	Title
DPN004476	Piping Schematic DA125, DA150, and DA250 with Liebert® MCV
DPN005206	Piping Schematic DA265 with Liebert® MCV
DPN005067	Piping Schematic XDM200/400 with Liebert® MCV

Table 5.2 Piping Arrangements Vertiv™ Liebert® MCV Condenser and Vertiv™ Liebert® EconoPhase Pump Locations

Document Number	Title
DPN003965	Air Cooled Piping Schematic Liebert® MCV Mounted Above Liebert® DA125-D250
DPN005207	Air Cooled Piping Schematic Liebert® MCV Mounted Above Liebert® DA265
DPN005138	Air Cooled Piping Schematic Liebert® MCV Mounted Above & Below Liebert® XDM200/400

Table 5.3 Piping Connection Drawings

Document Number	Title
DPN003887	Primary Connection Locations Liebert® MCV330 + Liebert® EconoPhase + Base Assy. 460V and 575v
DPN004954	Primary Connection Locations Liebert® MCV330 + Liebert® EconoPhase + Base Assy. 380V and 415V
DPN004953	Primary Connection Locations Liebert® MCV330 (2) + Liebert® EconoPhase + Base Assy. 380V and 415V
DPN003878	Primary Connection Locations Liebert® MCV330 + Liebert® EconoPhase (2) + Base Assy. 460V and 575V
DPN004257	Primary Connection Locations Liebert® MCV440 + Liebert® EconoPhase + Base Assembly
DPN004262	Primary Connection Locations Liebert® MCV440 (2) + Liebert® EconoPhase (2) + Base Assembly

5.1 Refrigerant Piping and Charging



WARNING! Risk of over pressurization of the refrigeration system. Can cause explosive discharge of high pressure refrigerant, loss of refrigerant, environmental pollution, equipment damage, injury or death. This unit contains fluids and gases under high pressure. Use extreme caution when charging the refrigerant system. Do not pressurize the system higher than the design pressure marked on the unit's nameplate.

Consult local building and plumbing codes for installation requirements of additional pressure relief devices when isolation valves are field installed. Do not isolate any refrigerant circuits from over pressurization protection.

NOTICE

Risk of oil contamination with water. Can cause equipment damage.

Vertiv™ Liebert® MCV systems require the use of POE (polyolester) oil. POE oil absorbs water at a much faster rate when exposed to air than previously used oils. Because water is the enemy of a reliable refrigeration system, extreme care must be used when opening systems during installation or service. If water is absorbed into the POE oil, it will not be easily removed and will not be removed through the normal evacuation process. If the oil is too wet, it may require an oil change. POE oils also have a property that makes them act as a solvent in a refrigeration system. Maintaining system cleanliness is extremely important because the oil will tend to bring any foreign matter back to the compressor.

Table 5.4 System Refrigerant Pressures

Maximum Design Operating Pressure (High Side)	530 psig	3655 kPa	Noted on the unit serial tag
---	----------	----------	------------------------------

5.1.1 Refrigerant Piping Guidelines for Air Cooled Systems

- Field installed interconnecting piping should be properly selected based on local codes and unit labeling.
- Air cooled units and condensers ship with an inert gas holding charge. Do not vent the charge until all refrigerant piping is in place, ready for connection to the unit and condenser.
- Use copper piping with a brazing alloy with a minimum temperature of 1,350°F (732°C), such as Sil-Fos. Avoid soft solders, such as 50/50 or 95/5.
- Use a flow of dry nitrogen through the piping during brazing to prevent formation of copper oxide scale inside the piping. When copper is heated in the presence of air, copper oxide forms. POE oils will dissolve these oxides from inside the copper pipes and deposit them throughout the system, clogging filter driers and affecting other system components.
- A pure dry nitrogen flow of 1-3 ft³/min (0.5-1.5 l/s) inside the pipe during brazing is sufficient to displace the air. Control the flow using a suitable measuring device.
- Ensure that the tubing surfaces to be brazed are clean and that all burrs have been removed from the ends of the tubes.
- Ensure that all loose material has been cleaned from inside the tubing before brazing.
- Protect all refrigerant line components within 18 in. (460 mm) of the brazing site by wrapping them with a wet cloth or with a suitable heat-sink compound.
- Isolate piping from building using vibration isolating supports.
- The Vertiv™ Liebert® MCV heat rejection skid cannot be installed below the evaporator.

- The DA125 through DA250 are used with a Liebert® MCV heat rejection skid with receiver tanks. For these systems, the outlet of the receivers on the outdoor Liebert® MCV heat rejection skid must be higher than the elevation of the electronic expansion valves (EEV) inside of the indoor unit. If the vertical height of the receiver outlet is greater than 60 ft. (18.3m) above the EEV, consult the factory. Refer to DPN003965 in [Submittal Drawings](#).
- The DA265 is used with a Liebert® MCV heat rejection skid without receiver tanks. For these systems, the bottom of the condenser coil on the outdoor Liebert® MCV heat rejection skid must be higher than the elevation of the EEVs inside of the indoor unit. If the vertical height between the condenser coil and the EEV is greater than 60 ft. (18.3m), consult the factory. Refer to DPN005207 in [Submittal Drawings](#).
- The XDM200/400 is used with a Liebert® MCV heat rejection skid without receiver tanks. For these systems, the bottom of the condenser coil on the outdoor Liebert® MCV heat rejection skid must be higher than the elevation of the EEVs inside of the indoor unit. If the vertical height between the condenser coil and the EEV is greater than 60 ft. (18.3m), consult the factory. Refer to DPN005138 in [Submittal Drawings](#) on page 67.
- Install traps on hot gas (discharge) lines at the base of the vertical risers over 5 ft. (1.5m) and then for vertical risers over 25 ft. (7.6m). Install a trap in 20 ft. (6m) increments or evenly divided over the vertical rise. The DA250 and DA265 each have piping out of the top of the unit with internally installed traps on the hot gas lines.
- Consult factory for piping lengths exceeding the lengths in **Table 5.5** below.

Table 5.5 Piping Lengths

Indoor Unit	Maximum Actual Length	Maximum Equivalent Length
DA250, DA265	200 ft. (61m)	300 ft. (91m)
DA125, DA150, DA165	300 ft. (91m)	450 (137.2m)

- Pitch horizontal hot gas piping down at a minimum rate of 1/2 in. per 10 ft. (42 mm per 10 m) so that gravity will aid in moving oil in the direction of refrigerant/oil flow.
- Keep piping clean and dry, especially on units with R-410A refrigerant.
- Avoid piping runs through noise sensitive areas.
- Do not run piping directly in front of discharge air stream.
- Refrigerant oil – do not mix oil types. Consult the indoor-unit installation/user guide for refrigerant type and oil requirements.

Refer to ASHRAE Refrigeration Handbook for general, good practice refrigeration piping. The indoor cooling unit has a factory installed high pressure safety switch in the high side refrigerant circuit. A fusible plug is installed in each Vertiv™ Liebert® DSE receiver.

NOTE: Liebert® DSE and Liebert® XDM systems require all indoor refrigerant piping to be insulated 1/2 in. minimum.

All outdoor field refrigeration piping does not need to be insulated. The installing contractor is responsible for the insulating, securing, protecting, and the proper installation of all field refrigerant piping, observing the details outlined by the Engineer of Record.

5.1.2 Refrigerant Charge Requirements

Table 5.6 Approximate R-410A Refrigerant Required per Circuit for Vertiv™ Liebert® MCV Heat Rejection Skid

Heat Rejection Skid	System No.	Circuit Number	Charge per Circuit with or without Receivers lb. (kg)
MCV330 Single skid with (1) PRE unit	1	1	52
		2	(24.6)
MCV440 Single skid with (1) PRE unit	1	1	62
		2	(28.1)
MCV330 Dual skid with (2) PRE units	1	1	52 (24.6)
		2	
	2	1	
		2	
MCV440 Dual Skid with (2) PRE units	1	1	62 (28.1)
		2	
	2	1	
		2	

*The heat rejection skid contains:

- Liebert® MCV condensers
- Liebert® DSE receivers, when used with a DA125 through DA250 system
- Liebert® EconoPhase (PRE) units, and all internal piping

Liebert® DSE receivers are not used with a DA265 system.

5.1.3 Additional Oil Requirements

Refer to the indoor unit's Installer/User Guide to determine if additional oil is required for each circuit. The need for additional oil is affected by compressor type, piping lengths, receiver, and total refrigerant charge.

5.2 System Dehydration/Leak Test

Refer to the indoor unit's Installer/User Guide for the leak check and evacuation procedures for the entire thermal-management system. Refer to the section that refers to the winter control system used on the condenser.

5.3 Charging for Condensers

Refer to the Liebert® DSE Installer/User Guide for the leak check and evacuation procedures for the entire thermal-management system.

6 Electrical Connections

Line voltage electrical service is required for all models. Electrical service must conform to national and local electrical codes. Refer to equipment nameplate regarding wire size and circuit protection requirements. Refer to electrical schematic when making connections. Refer the appropriate submittal drawing, listed in **Table 6.1** on the next page, for electrical service entrances into unit.

A manual electrical disconnect switch should be installed in accordance with local codes and distribution system. Consult local codes for external disconnect requirements.

All internal wiring is completed at the factory.



WARNING! Arc flash and electric shock hazard. Open all local and remote electric power supply disconnect switches, verify with a voltmeter that power is Off and wear appropriate, OSHA-approved personal protective equipment (PPE) per NFPA 70E before working within the electric control enclosure. Failure to comply can cause serious injury or death. Customer must provide earth ground to unit, per NEC, CEC, and local codes, as applicable. Before proceeding with installation, read all instructions, verify that all the parts are included and check the nameplate to be sure the voltage matches available utility power. The Vertiv™ Liebert® iCOM™ controller does not isolate power from the unit, even in the Unit Off mode. Some internal components require and receive power even during the Unit Off mode of the Liebert® iCOM™ controller. The only way to ensure that there is NO voltage inside the unit is to install and open a remote disconnect switch. Refer to unit electrical schematic. Follow all local codes.



WARNING! Risk of improper wiring, piping, moving, lifting and handling. Can cause equipment damage, serious injury or death. Installation and service of this equipment should be done only by qualified personnel who have been specially trained in the installation of air conditioning equipment and who are wearing appropriate, OSHA-approved PPE.



WARNING! Risk of improper wire sizing/rating and loose electrical connections. Can cause overheated wire and electrical connection terminals resulting in smoke, fire, equipment and building damage, injury or death. Use correctly sized copper wire only and verify that all electrical connections are tight before turning power On. Check all electrical connections periodically and tighten as necessary.

NOTICE

Risk of improper power supply connection. Can cause equipment damage and loss of warranty coverage.

Prior to connecting any equipment to a main or alternate power source (for example: backup generator systems) for start up, commissioning, testing, or normal operation, ensure that these sources are correctly adjusted to the nameplate voltage and frequency of all equipment to be connected. In general, power source voltages should be stabilized and regulated to within $\pm 10\%$ of the load nameplate nominal voltage. Also, ensure that no three phase sources are single phased at any time.

NOTE: Use copper wiring only. Make sure that all connections are tightened to the proper torque mentioned on the component.

The electrical connections are described in the submittal documents included in the [Submittal Drawings](#).

The following table lists the relevant documents by number and title.

Table 6.1 Electrical Field Connection Drawings

Document Number	Title
DPN003879	Electrical Panel Layout Liebert® MCV330
DPN004212	Electrical Panel Layout, Liebert® MCV440 Condenser Section
DPN003887	Primary Connection Locations Liebert® MCV330 + Liebert® EconoPhase + Base Assy. 460V and 575V
DPN003878	Primary Connection Locations Liebert® MCV330 + Liebert® EconoPhase + Base Assy. 460V and 575V
DPN004954	Primary Connection Locations Liebert® MCV330 + Liebert® EconoPhase + Base Assy. 380V and 415V
DPN004953	Primary Connection Locations Liebert® MCV330 (2) + Liebert® EconoPhase + Base Assy. 380V and 415V
DPN004257	Primary Connection Locations Liebert® MCV440 + Liebert® EconoPhase + Base Assembly
DPN004262	Primary Connection Locations Liebert® MCV440 (2) + Liebert® EconoPhase (2) + Base Assembly
DPN003886	CANbus and Interlock Connections Liebert® MCV + Liebert® EconoPhase + Base Assy.

6.1 Line Voltage Wiring



WARNING! Risk of electrical fire and short circuit. Can cause property damage, injury or death. Select and install the line side electrical supply wire and overcurrent protection device(s) according to the specifications on the unit nameplate(s), per the instructions in this manual and according to the applicable national, state, and local code requirements. Use copper conductors only. Verify that all electrical connections are tight. Unit specific wiring diagrams are provided on each unit.

NOTICE

Risk of improper power supply connection. Can cause equipment damage and loss of warranty coverage.

Prior to connecting any equipment to a main or alternate power source (for example: backup generator systems) for start up, commissioning, testing, or normal operation, ensure that these sources are correctly adjusted to the nameplate voltage and frequency of all equipment to be connected. In general, power source voltages should be stabilized and regulated to within $\pm 10\%$ of the load nameplate nominal voltage. Also, ensure that no three phase sources are single phased at any time.

NOTE: For acceptable and unacceptable power supplies, see [Wye vs. Delta Connected Power Supply for EC Fans](#) on page 20.

Condenser rated voltage should be verified with available power supply before installation. Refer to the unit's electrical schematic and serial tag for specific electrical requirements.

Vertiv™ Liebert® MCV condenser power connections are provided for three phase wires and one earth ground wire. Line voltage electrical service is required for all condensers at the location of the condenser. The voltage supply to the condenser may not be the same voltage supply as required by the indoor unit. Consider using a UPS on both indoor cooling units and Liebert® MCV condensers to maintain uninterrupted cooling capability. Refer to the unit's serial tag for specific condenser electrical requirements. A unit disconnect is standard. However, a site disconnect may be required by local code to isolate the unit for maintenance. Route the supply power to the site disconnect switch and then to the unit. Route the conduit to the knockout provided in the bottom right end of the electrical control enclosure. Connect the earth ground wire lead to the marked earth ground connection terminal provided near the factory installed disconnect switch per the appropriate drawing in the [Submittal Drawings](#).

NOTE: A separate neutral wire does not need to be run to the Liebert® MCV Condenser.

Table 6.2 Vertiv™ Liebert® MCV Condenser Only Electrical Data, 3 Phase

Model	Voltage	FLA	WSA	OPD
MCV330	2 = 380V/60Hz	21.0	21.9	25
	A = 460V/60Hz	16.8	17.5	20
	M = 380-415V/50Hz	21.0	21.9	25
	G = 415V/50Hz	21.0	21.9	25
MCV440	2 = 380V/60Hz	28.0	28.9	30
	A = 460V/60Hz	22.4	23.1	25
	M = 380-415V/50Hz	28.0	28.9	30
	G = 415V/50 Hz	28.0	28.9	30

Source: DPN005045, Rev. 4

Table 6.3 Heat Rejection Skid Electrical Data, 3 Phase

Model	Voltage	FLA	WSA	OPD
MCV330 + PR125	2 = 380V/60Hz	29.4	30.5	35
	A = 460V/60Hz	23.8	24.7	25
	G = 415V/50Hz	28.4	29.3	30
	B = 575V/60Hz	19.0	19.7	30
MCV330 + PR200	2 = 380V/60Hz	NA	NA	NA
	A = 460V/60Hz	21.4	22.1	25
	G = 415V/50Hz	N/A	N/A	N/A
	B = 575V/60Hz	N/A	N/A	N/A
MCV440 + PRE	2 = 380V/60Hz	36.4	37.5	40
	A = 460V/60Hz	29.4	30.3	35
	G = 415V/50Hz	35.4	36.3	40
	B = 575V/60Hz	23.5	24.2	35

FLA = Full Load Amps; WSA = Wire Size Amps; OPD = Maximum Overcurrent Protection Device.
Source: DPN005045, Rev. 4

NOTE: Heat rejection skids with 12 or 16 fans contain two 3 phase connection boxes, and each box requires a separate supply input per Table 6.3 above.

6.2 Wye vs. Delta Connected Power Supply for EC Fans

Acceptable Power Supplies—380 V to 460 V Nominal Units

- 380V wye with solidly grounded neutral and 220V line to ground
- 480V wye with solidly grounded neutral and 277V line to ground
- Wye with high resistance (or impedance) ground
- Delta with corner ground

Unacceptable Power Supplies

- Delta without ground or with floating ground
- Delta with grounded center tap

6.3 Wye vs. Delta Connected Power Supply for Alternative EC Fans

Figure 6.1 Power Supply Requirements for 380V-575V Units: Acceptable

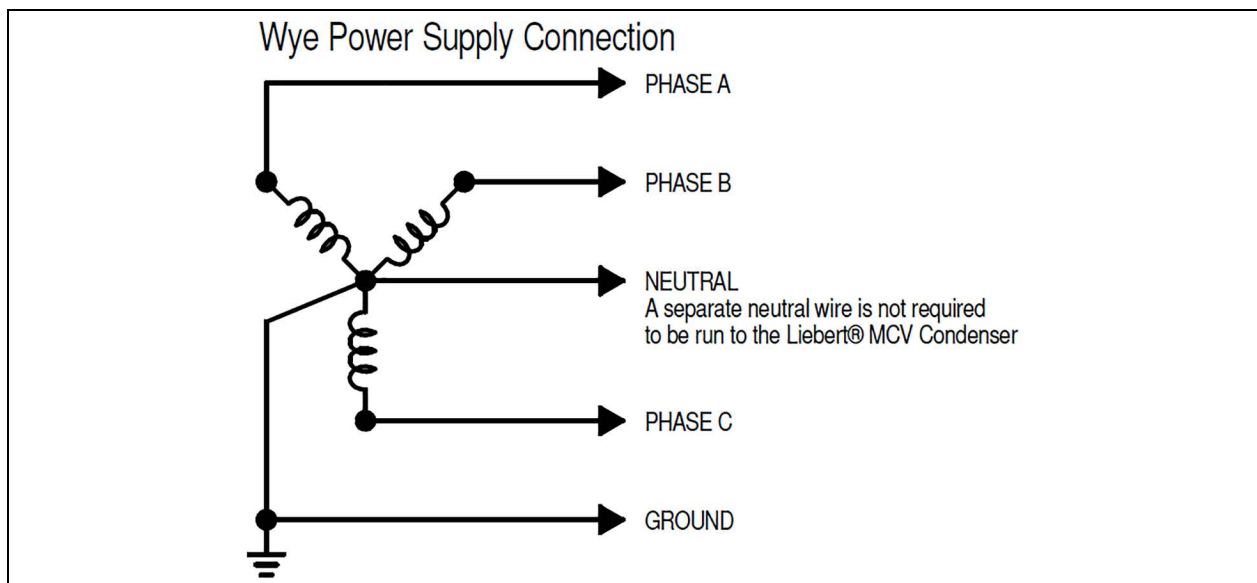
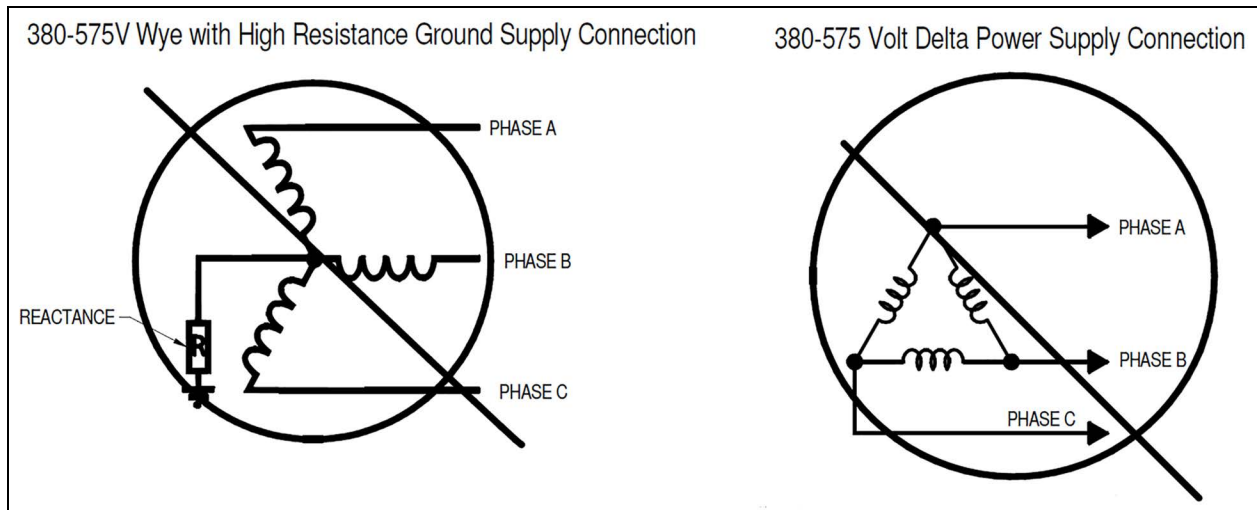

Figure 6.2 Unacceptable



NOTE: The 380-575 volt unit is designed to operate with Wye-connected power with a solidly grounded neutral. It will not operate properly with Wye-connected power with high-resistance (or impedance) ground or with Delta-connected power. A separate neutral wire is not required to be run to the Liebert® MCV Condenser.

Acceptable Power Supplies—380-575V Nominal Units

- 380-575V wye with solidly grounded neutral and 277V line-to-neutral

Unacceptable Power Supplies— 380-575V Nominal Units

- Wye with high-resistance (or impedance) ground
- Delta without ground or with floating ground
- Delta with corner ground
- Delta with grounded center tap

Service Kit Number for ROSENBERG EC FAN: 10027590P1S

Liebert® MCV330 units with Rosenberg EC Fans must use Service Kit number 10027590P1S.

No other EC Fan replacement kit part number allowed.

6.4 Low Voltage Control Wiring—CANbus Communication

NOTICE

Risk of control malfunction. Can cause improper unit operation.

Verify that all low voltage electrical wiring has been performed per the schematic diagram provided and that all low voltage wiring connections are tight.

CANbus communication and interlock wiring are required between the indoor and the outdoor units. CANbus cables are supplied by others to connect the indoor unit to the outdoor condenser. No special considerations are required when the total external cable connection between the indoor unit and outdoor unit is less than 450 ft. (137 m). A CANbus isolator is required for total external cable connections longer than 450 ft. (137 m) but less than 800 ft. (243 m).

The control wiring connections are described in the submittal documents included in the [Submittal Drawings](#).

The following tables list the relevant documents by number and title.

Table 6.4 CANbus Communication Connection Drawings

Document Number	Title
DPN003886	CANbus and Interlock Connections between Unit and Condenser

7 Checklist for Completed Installation

7.1 Moving and Placing Equipment

1. Unpack and check received material.
2. Proper clearance for service access has been maintained around the equipment.
3. Equipment is level and mounting fasteners are tight.

7.2 Electrical Installation Checks

1. Line voltage connected and matches equipment nameplate.
2. Power line circuit breakers or fuses have proper ratings for equipment installed.
3. CANbus communication and interlock wiring connections completed between indoor cooling unit and condenser.
4. All internal and external high and low voltage wiring connections are tight.
5. Confirm that unit is properly grounded to an earth ground.
6. Control transformer setting matches incoming power.
7. Electrical service conforms to national and local codes.
8. Verify that the condenser is not connected to an unacceptable power supply, see [Wye vs. Delta Connected Power Supply for EC Fans](#) on page 20.
9. Verify that the CANbus wiring, CANbus END of Line jumper position, and the CANbus Device Address DIP Switch setting are correct according to the application at the job site.
10. Verify that terminals 70, 71, (and 230 when applicable) are used and properly wired for interlock wiring, particularly on systems that use two condensers for one indoor unit.

7.3 Piping Installation Checks

1. Piping completed to corresponding indoor cooling unit refrigeration circuit.
2. Piping is leak checked, evacuated, and charged with specified refrigerant.
3. Additional refrigerant oil is added per circuit, if required.
4. Piping is properly sized, sloped, and trapped for proper oil return.
5. Check piping inside and outside of equipment for proper support and adequate spacing to prevent rub through or chafing.

7.4 Other Installation Checks

1. Installation materials and tools have been removed from equipment (literature, shipping materials, construction materials, tools, etc.).
2. Locate blank start-up sheet, ready for completion by installer or start-up technician.

This page intentionally left blank

8 Initial Start-up Checks and Commissioning Procedure for Warranty Inspection



WARNING! Arc flash and electric shock hazard. Open all local and remote electric power supply disconnect switches, verify with a voltmeter that power is Off and wear appropriate, OSHA-approved personal protective equipment (PPE) per NFPA 70E before working within the electric control enclosure. Failure to comply can cause serious injury or death. Customer must provide earth ground to unit, per NEC, CEC and local codes, as applicable. Before proceeding with installation, read all instructions, verify that all the parts are included and check the nameplate to be sure the voltage matches available utility power. The Vertiv™ Liebert® iCOM™ controller does not isolate power from the unit, even in the Unit Off mode. Some internal components require and receive power even during the Unit Off mode of the Liebert® iCOM™ controller. The only way to ensure that there is NO voltage inside the unit is to install and open a remote disconnect switch. Refer to unit electrical schematic. Follow all local codes.



WARNING! Risk of improper wiring, piping, moving, lifting and handling. Can cause equipment damage, serious injury or death. Installation and service of this equipment should be done only by qualified personnel who have been specially trained in the installation of air conditioning equipment and who are wearing appropriate, OSHA-approved PPE.



WARNING! Risk of contact with high speed rotating fan blades. Can cause serious injury or death. Open all local and remote electric power supply disconnect switches, verify with a voltmeter that power is off, and verify that all fan blades have stopped rotating before working in the unit cabinet or on the fan assembly. If control voltage is applied, the fan motor can restart without warning after a power failure. Do not operate the unit with any or all cabinet panels removed.



CAUTION: Risk of exposure to harmful noise levels. Can cause hearing injury or loss. Depending on the installation and operating conditions, a sound pressure level greater than 70 dB(A) may arise. Take appropriate technical safety measures. Operating personnel must wear appropriate, OSHA-approved PPE and observe all appropriate hearing-protection safety requirements.

- Confirm that all items on [Checklist for Completed Installation](#) on page 23 have been done.
- Locate the “Liebert® MCV Warranty Inspection Check Sheet” in the unit’s electric panel. (PSWI-8542-408CO).
- Complete the “Liebert® MCV Warranty Inspection Check Sheet” during start-up. (PSWI-8542-408CO).
- Forward the completed “Liebert® MCV Warranty Inspection Check Sheet” to your local sales office. **This information must be completed and forwarded to validate warranty.**
- Contact your local sales representative or technical support if you have any questions or problems during unit start-up and commissioning. Visit <https://www.Vertiv.com/en-us/support/> or call 1-800-543-2778 for contacts.

This page intentionally left blank

9 Troubleshooting

When an Vertiv™ Liebert® EconoPhase unit triggers an alarm, please refer to the *Liebert® EconoPhase Installer/User Guide* available on the product page at www.Vertiv.com.

Table 9.1 Troubleshooting MCV Condenser Section

Symptom	Possible Cause	Check or Remedy
Condenser will not start	No power to condenser.	Check voltage at input terminal block.
	Circuit breaker or fuse for low voltage transformer in condenser is tripped.	Locate problem in condenser electrical panel and repair.
	No low voltage signal to/from indoor unit.	Locate open circuit and repair.
Low discharge pressure	Faulty head pressure control valve or premium efficiency control board.	Replace if defective.
High discharge pressure	Dirty condenser fins.	Clean coil.
	Condenser fans not operating.	Check for low voltage signal from indoor unit.
		Check fan motors and fuses.
High refrigerant charge	Check refrigerant charge.	
SPD green and red LEDs are extinguished	No voltage or improper phasing exists at condenser.	Check voltage at input terminal block.
	Electrical connections to SPD are faulty.	Locate connection problem and repair.
	Condenser disconnect is turned Off.	Recheck lights with disconnect switch in the On position.
SPD red LED is illuminated	A surge exceeding the rating of the SPD has occurred.	Replace SPD and inspect other components for damage and replace them if necessary.
Control Board LEDs do not light.	Connection to P24 is loose or disconnected.	Check the connection to P24 to verify that is connected securely.
		Check the connector from the transformer for loose terminals.
	Fuse located next to P24 has blown.	Verify that the fuses next to P24 have not blown. Replace as needed.
	24V transformer has failed.	With a voltmeter verify that the output from the transformer is 24Vac \pm 10%. If the value exceeds \pm 10%, verify that the correct primary leads are being used.
Premium Efficiency Control Board has failed.	If there is no output voltage, verify that the primary connections are secure and receiving the correct voltage. If they are, replace the transformer.	
Fan will not run	Jumper not installed in fans, if needed.	Install a jumper if schematic states one is needed based on fan supplier.
	Communication cable connections are loose or incorrect.	Check wiring at each of the fans.
	Fan address is not properly defined.	Use the parameter list label on the door to find the correct fan parameters. Verify that the fan has the correct manufacturer and address selected.

This page intentionally left blank

10 Control Operation

The Vertiv™ Liebert® MCV Premium Efficiency Control takes about 30 seconds to boot during which time, the LED on the Premium Efficiency Control Board reads “888.” When fully booted, “F00” displays, then the value for F00. When using the control, the condenser fan(s) respond less than 5 seconds after receiving a compressor or signal from the indoor unit. Consider using UPS equipment on both data center cooling units and Liebert® MCV condensers to maintain uninterrupted cooling capability.

For the first 60 seconds of operation after the compressor turns on, the condenser fan(s) run at a factory set fixed speed, based on ambient temperature: faster at higher temperatures, slower at lower temperatures. After 60 seconds, the control adjusts the fan speed based on the liquid pressure transducer. If the liquid-pressure transducer fails, the condenser uses temperature sensors to control the fan speed based on the liquid line temperature. The condenser fans continue to operate for approximately 30 seconds after compressors turn off.

The Liebert® MCV fans have various alarm conditions, such as loss of voltage and loss of control signal, that stop the condenser fans. When an alarm condition is no longer present, the fans turn on automatically if compressors are on.

10.1 Vertiv™ Liebert® EconoPhase Pumped Refrigerant Economizer with a Vertiv™ Liebert® DSE System

Liebert® DSE systems are designed to provide precision air conditioning to computer racks in a data center or computer room as efficiently and effectively as possible.

A Liebert® DSE system with Liebert® EconoPhase is composed of individually-shipped components or components assembled together on skids. Some examples are:

System example 1

- Liebert® DSE—High efficiency, floor mounted indoor unit
- Liebert® MC Condenser—Air cooled microchannel condenser, premium version
- Liebert® EconoPhase—Liebert® EconoPhase pumped-refrigerant economizer (PRE)

System example 2

- Liebert® DSE—High efficiency, floor mounted indoor unit
- Liebert® MCV Heat rejection skid—Air cooled microchannel condenser, premium version with a Liebert® EconoPhase pumped refrigerant economizer (PRE)

The Liebert® EconoPhase PRE is an add on module for use with an air cooled Liebert® DSE system. The Liebert® EconoPhase allows the system to switch to Liebert® EconoPhase operation when the outdoor temperature is low enough to provide the required temperature difference between the inside air and the outside air, which, in turn, provides significant energy savings because the compressor(s) do not operate. At lower temperatures, the system switches one or both circuits from Compressor Mode to Pump Mode. The pump consumes roughly one-tenth of the power consumed by the compressor.

The Liebert® EconoPhase system maintains this energy efficiency by employing the heat absorption properties of a liquid (pumped refrigerant) through a phase change. Refrigerant is pumped as a liquid, becomes a gas within the Liebert® DSE evaporator and is then returned to the condenser where it condenses to a liquid. The subcooled liquid refrigerant from the condenser is run directly into the Liebert® EconoPhase pumps and circulates back to the Liebert® DSE unit (see **Figure 10.1** on the next page). The system operates as a typical air cooled direct expansion system when outdoor ambient conditions are unfavorable to Liebert® EconoPhase operation. The pumps in the Liebert® EconoPhase PRE are turned off and bypassed during compressor operation.

Figure 10.1 Vertiv™ Liebert® EconoPhase Pumped Refrigerant Pressure Enthalpy Diagram

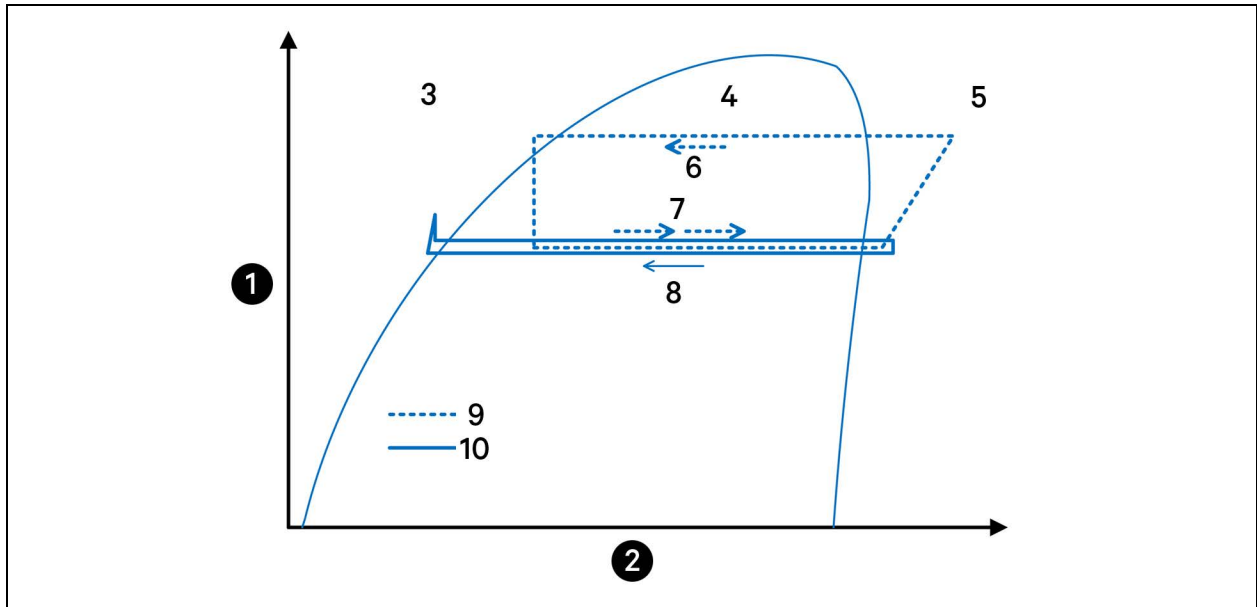

Item	Description	Item	Description
1	Pressure	6	Condenser (DX mode)
2	Enthalpy	7	Indoor unit
3	Liquid	8	Condenser (pump mode)
4	Liquid/vapor maximum	9	Traditional vapor compression cycle
5	Vapor	10	EconoPhase cycle

10.2 Overview of Operating Modes

Each circuit on a system combining a Vertiv™ Liebert® EconoPhase, Vertiv™ Liebert® DSE and Vertiv™ Liebert® MCV condenser has six distinct operating modes:

- Idling with compressor and pumps Off
- Start-up
- Compressor operation
- Compressor to pump changeover
- Pump operation
- Pump to compressor changeover

A circuit will run most of the time in either compressor or pump operation mode. These modes both efficiently remove heat from the conditioned space and reject it via the air cooled condenser. The flow paths during each mode of operation are detailed in [Compressorized Operation Flow Path](#) below and [Pump Operation Flow Path](#) on the next page.

A couple of differences to note between Compressor Mode and Vertiv™ Liebert® EconoPhase operation:

- The unit does not dehumidify in Liebert® EconoPhase operation. If dehumidification is desired, Liebert® EconoPhase operation must be disabled.
- Bubbles may be seen in the site glass in the indoor unit when the system is in Liebert® EconoPhase operation. This does not necessarily mean the system is low on charge. Refer to the Liebert® DSE user manual (available at www.Vertiv.com) for complete charging instructions for the Liebert® DSE/EconoPhase system.

Figure 10.2 Compressorized Operation Flow Path

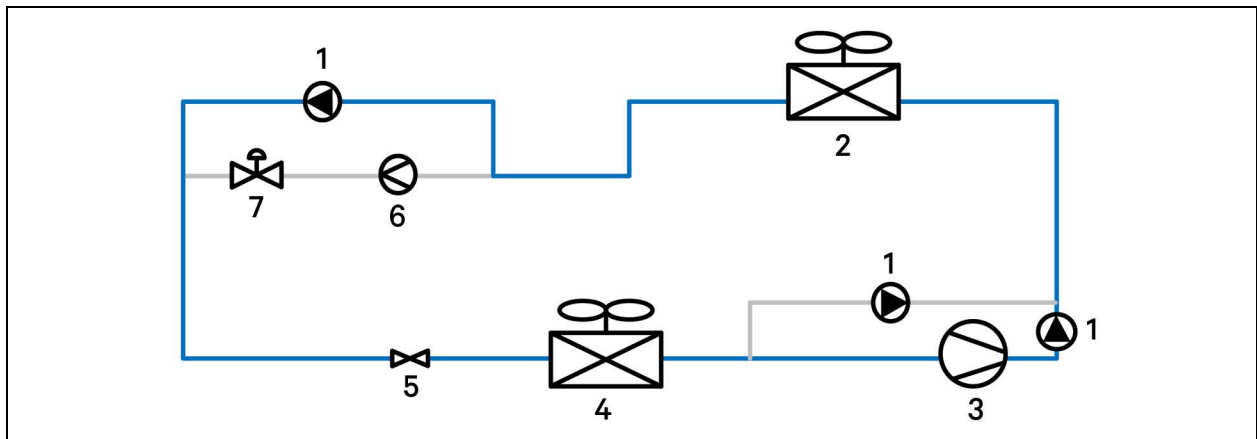

Item	Description	Item	Description
1	Check valve	5	Electronic expansion valve (EEV)
2	Condenser	6	Pump
3	Compressor	7	Solenoid valve
4	Evaporator		

Figure 10.3 Pump Operation Flow Path

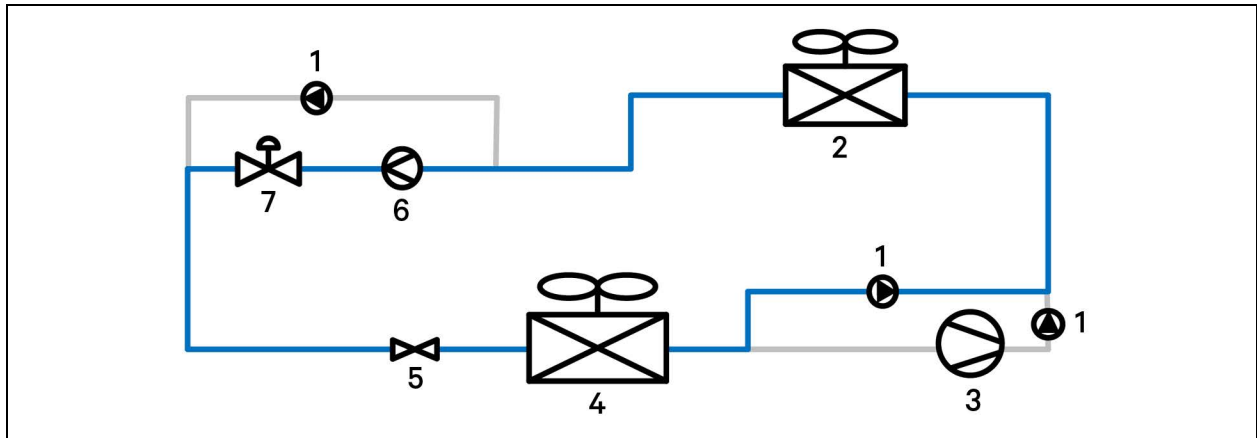

Item	Description	Item	Description
1	Check valve	5	Electronic expansion valve (EEV)
2	Condenser	6	Pump
3	Compressor	7	Solenoid valve
4	Evaporator		

10.3 Vertiv™ Liebert® EconoPhase Operation

The Liebert® EconoPhase unit enables the Vertiv™ Liebert® DSE system to operate in any of three modes to control temperature, depending on the outdoor temperature and the load.

- Compressor Mode
- Pump Mode
- Mixed Mode

When the outdoor temperature becomes low enough to provide the required temperature difference between the inside air and the outside air, there is no need to compress the refrigerant to a higher pressure/temperature. When the outdoor temperature is low enough, the system switches from Compressor Mode to Pump Mode or to Mixed Mode.

- Compressor Mode: All available compressors may be used to maintain the control temperature. All the available Liebert® EconoPhase pumps are Off. The control will typically run in this mode when the load and temperatures are such that full or partial Liebert® EconoPhase operation is not possible, or because certain pumps have experienced alarms.
- Pump Mode: All of the available pumps may be used to maintain the Control Temperature. All the compressors in the system are Off. The control will typically run in this mode when load and temperatures permit.
- Mixed Mode: (Dual pump models only): The pump in Circuit 1 is On and the compressor(s) in Circuit 2 is On. Some systems may not have Mixed Mode capability, depending on the manufacture date. Contact the factory to inquire about a software upgrade.

10.3.1 Vertiv™ Liebert® EconoPhase Control

Liebert® EconoPhase operation has three main controlled parameters:

- Room temperature
- Refrigerant temperature
- Pump pressure differential (outlet pressure - inlet pressure)

Room Temperature

When the system is in Pump Mode, the room temperature is controlled by modulating the pump speed with a variable frequency drive. The load requirement will determine if one pump or two are needed. **Figure 10.4** below, shows the sequence of operation in terms of pump speed. Minimum speed is 45% and maximum speed is 100%. See **Table 10.1** below, for more detail on the events depicted and the conditions that trigger action.

Figure 10.4 Two Circuit Pump Control

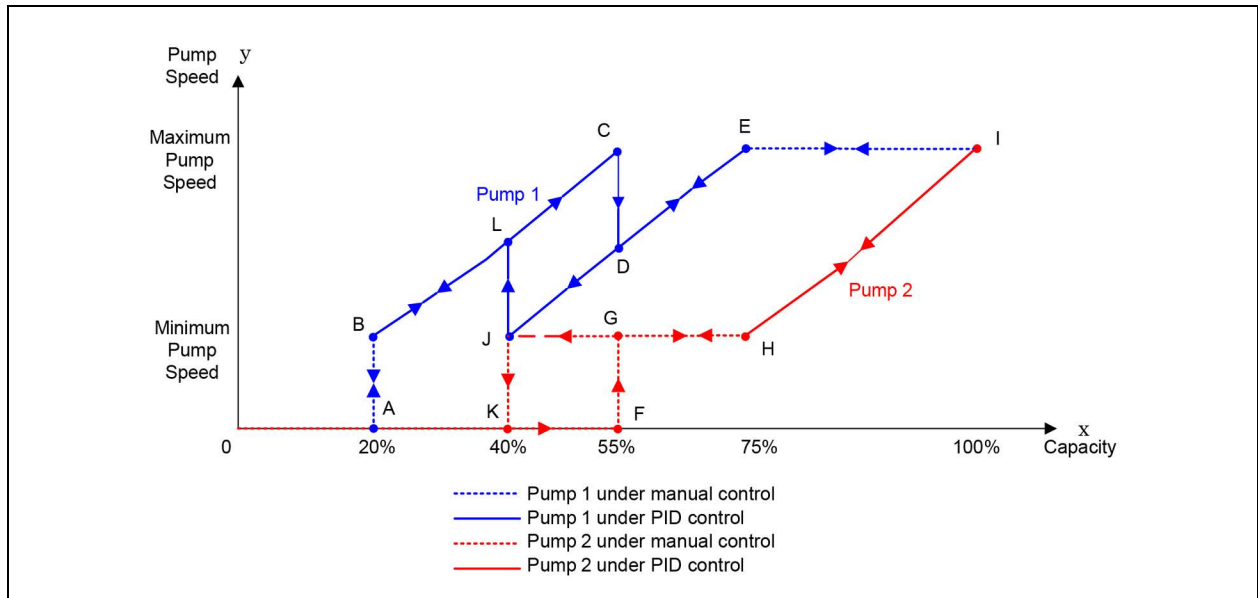

Table 10.1 Events and Actions of 2 Circuit Pump Control

Event	Condition to Trigger Action	Action
B to A	Pump 2 Off; and Pump 1 at minimum speed for 60 sec; and Delta T [indoor air temperature - setpoint] <-4°F (2.2°C)	Pump 1 turns Off. Pump 2 remains Off.
A to B	Both Pump 1 and Pump 2 Off and Delta T >0°F (0°C)	Pump 1 turns On and runs on PID. Pump 2 remains Off.
F to G	Pump 2 Off and Pump 1 at maximum speed for 600 seconds and Delta T >1°F (-0.6°C)	Pump 2 turns On at starting speed, then goes to minimum speed immediately. Pump 1 continues to run on PID.

Table 10.1 Events and Actions of 2 Circuit Pump Control (continued)

Event	Condition to Trigger Action	Action
At E and H upward	Pump 1 at maximum speed; and Pump 2 at minimum speed and Delta T >1°F (-0.6°C)	Pump 1 runs at maximum speed, while Pump 2 runs on PID.
At E and H downward	Pump 1 at maximum speed; and Pump 2 at minimum speed; and Delta T < -1°F (-0.6°C)	Pump 1 runs on PID, while Pump 2 runs at minimum speed.
J to K	Both Pump 1 and Pump 2 at minimum speed for 60 sec. and Delta T < -1°F (-0.6°C)	Pump 2 turns Off, while Pump 1 runs at minimum speed.
Pump 2 Early Start-up	Pump 2 Off and Delta T >2°F (1.1°C)	No action to Pump 1; turn On Pump 2 at 80% speed. Once the start-up procedure is finished, step change to minimum speed immediately.

In the case of a transition from Compressor Mode to Pump Mode, the pumps will be given initial speeds based on the call for cooling at the time of transition. The pumps will go to this initial speed after the start-up routine is completed. This will mean that, depending on the load, both pumps will start immediately at the transition to Pump Mode from Compressor Mode.

When the system is in Mixed Mode, the room temperature is controlled either by modulating the digital compressor(s) on Circuit 2 with the pump on Circuit 1 at 100%, or by modulating the pump speed on Circuit 1 with the compressor(s) operating at the minimum digital percent.

Refrigerant Temperature

When a circuit is running in Pump Mode, the refrigerant temperature is controlled by the condenser fan speed. When a circuit switches from Compressor Mode to Pump Mode, the condenser fan speed control changes from pressure control to temperature control, with the controlled parameter being condenser outlet refrigerant temperature.

The default setpoint on Circuit 1 is 45°F, while on Circuit 2 it is 37°F. The condenser fan speed will modulate to provide the respective temperature. But if the outdoor temperature is warm enough, or if the load is high enough, the fans might be at 100% and the actual refrigerant temperature might be above the setpoint. In that case, the temperature will depend on the heat rejection capability of the condenser at the given conditions.

Actual fan speed will depend on the load and the outdoor temperature. The fan speed will be lower for a given heat load with lower outdoor temperature in order to maintain the setpoint.

Because the refrigerant temperature could be below the dew point inside, the indoor piping must be insulated to prevent condensation. In addition, the outdoor piping must be insulated so that heat is not lost to the outdoor air at very low ambient temperatures, causing the refrigerant temperature to fall and increasing the possibility of frost at the evaporator.

Pump Pressure Differential

The pump pressure differential must be maintained above a minimum for cooling and lubricating flow to be provided to the pump motor and bearings. The differential is controlled by EEV position. When the system switches to EconoPhase operation, the EEV control changes from superheat control to manual control. The Vertiv™ Liebert® iCOM™ controller then signals the EEV to control its position based on pump differential. Unless during pump mode operation, the suction superheat drops below the minimum acceptable level, then the EEV will begin to close and restrict refrigerant mass flow to build superheat.

The pump differential setpoint is 20 psid. If the pump is running at a high speed at a steady rate, the actual pump differential may be above 25 psid.

If the pump differential drops below 5 psid continuously for 30 minutes, the system will switch to direct expansion mode for 30 minutes. The system will switch back to Vertiv™ Liebert® EconoPhase if the conditions are still qualified for pump operation.

10.3.2 Pump Start-up Routine

When either pump attempts to start, the first attempt will be at 80% of full speed. If flow is not established (as detected by pump differential being at least 12 psid within 60 seconds), the pump will turn Off for 10 seconds before trying again at 90% speed. If flow is still not established, the pump will turn Off for 10 seconds before trying again at 100% speed. If flow is not established after the 100% speed attempt, the system will switch to DX mode for 10 minutes before attempting to start the pumps again if the conditions are still compatible.

The second start-up routine is the same as above. If the second start-up attempt is unsuccessful, the system will switch to DX mode for 60 minutes before trying again.

The third start-up routine will be the same as above. If the third start-up attempt is unsuccessful, a Pump Startup Fail alarm will be displayed and Vertiv™ Liebert® EconoPhase operation will be locked out until the user manually resets the event at the Vertiv™ Liebert® iCOM™.

10.3.3 Switch from Compressor Operation to Pump Operation

The Vertiv™ Liebert® iCOM™ runs the system in the most efficient operating mode, given the load and temperature conditions. If Mixed Mode is available, the system will change from Compressor Mode to Mixed Mode when partial Vertiv™ Liebert® MCV operation is possible and from Compressor or Mixed Mode to Pump Mode when full Liebert® MCV operation is possible.

10.3.4 Switch from Pump Operation to Compressor Operation

The unit will switch from Pump Mode to Mixed Mode or Compressor Mode when at least one of the following is true:

- The difference between the actual controlled air temperature and the setpoint is 75% into the Cooling Proportional Band for five minutes. The default is 75%, but the percentage can be changed at the Vertiv™ Liebert® iCOM™.

NOTE: At start-up and at switchover from compressor operation to pump operation, more time is allowed to bring the temperature under control, but the temperature will never be allowed to go outside the cooling proportional band + 2°F (1.2°C).

- The pump differential pressure is below 5 psid for 30 minutes.
- The refrigerant temperature leaving the pump is below 30°F for 60 minutes.
- The pump does not establish flow at a pump start-up attempt.
- Power is lost at the Vertiv™ Liebert® EconoPhase unit.

10.4 Premium Efficiency Control Board and Interface

The Premium Efficiency Control board has a stacked-board arrangement. The human machine interface consists of three 7 segment LEDs and keys (see **Figure 10.6** on the facing page).

NOTE: Indicator lights should be On to indicate signal is present. See Figure 10.5 below.

The Premium Efficiency Controls are factory configured for refrigerant type, whether or not a receiver is included, and the indoor cooling unit. No field configuration is necessary for proper and efficient condenser operation.

Figure 10.5 Premium Efficiency Fan Control Board

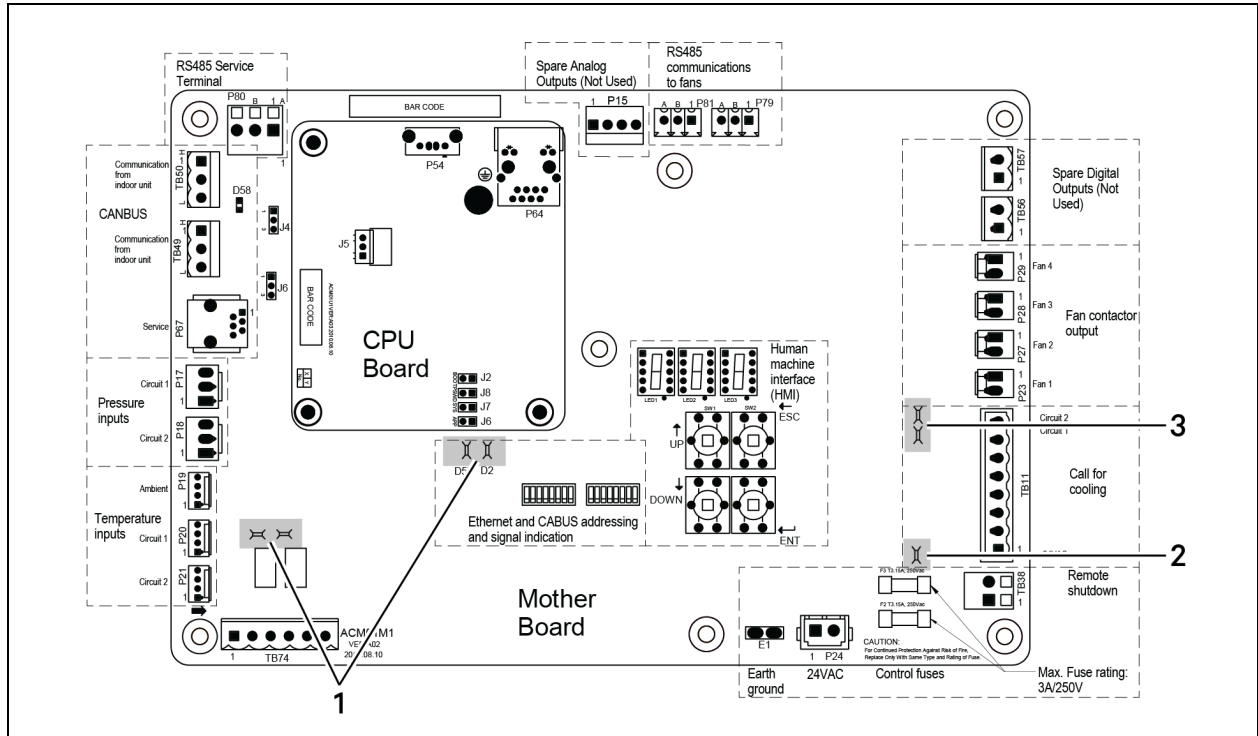

Item	Description
1	LED indicates signal is present when lit.
2	LED indicates signal is present when lit.
3	LED indicates signal is present when lit.

Figure 10.6 Control Board HMI

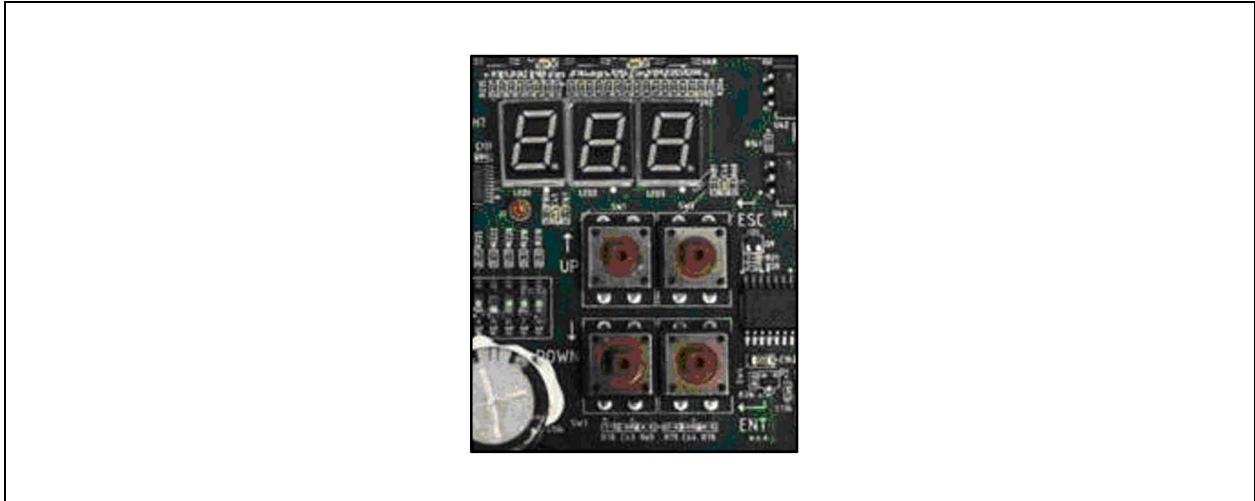

10.4.1 Initial Display upon Power On

After power on, first item of the analog signals menu displays. *F00* and the pressure value of condenser 1 display alternately. *F00* is the item ID of Condenser Pressure 1, see **Table 10.2** on page 40, for the description of the analog signal item IDs.

Figure 10.7 below, shows the alternating ID and example compressor 1 pressure of 16.1.

Figure 10.7 Initial Display on the Controller

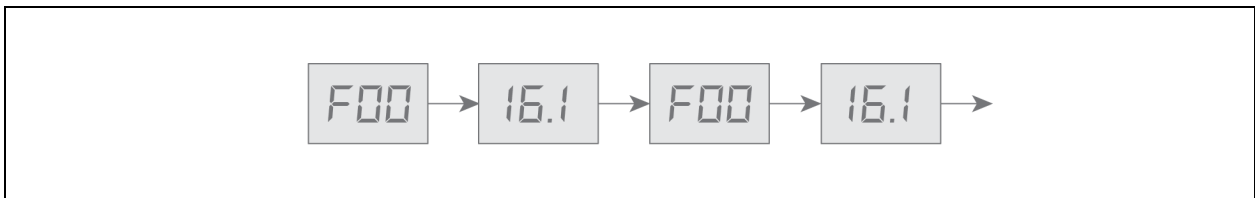

10.4.2 Navigating the Controller Interface Main Menu

At the initial display, press ESC to display the first item of the main menu, which includes four options:

- Analog Signals Menu
- Active Alarms Menu
- History Alarms Menu
- Configuration Menu

Use the Up and Down keys to scroll through the menus, and press ENT to enter the sub menus. **Figure 10.8** on the next page, shows the operation and structure of the main menu.

Figure 10.8 Main Menu Operation and Structure

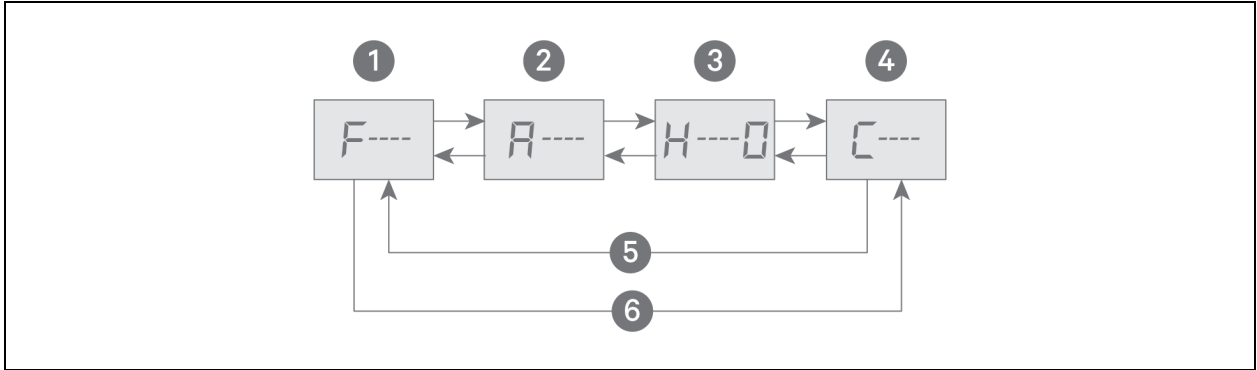

Item	Description
1	Analog signals menu
2	Active alarms menu
3	History alarms menu
4	Configuration menu
5	Pressing up arrow from analog signals displays the configuration menu.
6	Pressing down arrow from configuration menu displays the analog signals menu.

NOTICE

Risk of improperly altered configuration menu settings. Can compromise equipment operation.

Changing the configuration menu settings can cause unanticipated results. These settings should be changed only by properly trained and qualified personnel or as directed by the factory.

10.4.3 Analog Signals Menu

In the analog signals menu, F--, press ENT to enter the analog signal items described in **Table 10.2** on page 40. The item ID and signal value display alternately. **Figure 10.9** on the facing page, shows the operation and item structure of analog signals menu.

Figure 10.9 Analog Signals Menu

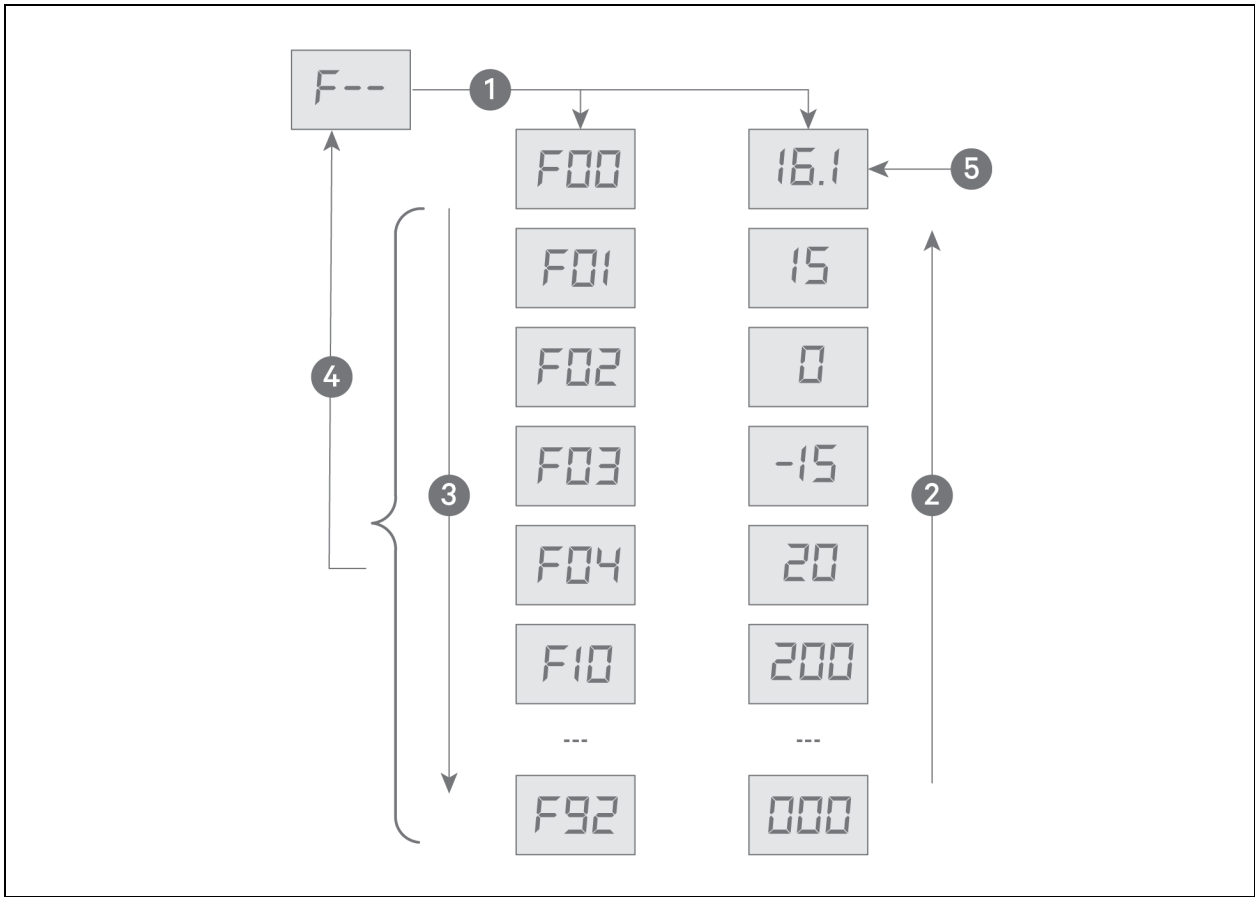

Item	Description
1	Pressing ENT displays the first analog signal item which alternately displays the ID and the reading.
2	Pressing up arrow, cycles up through the menu items/readings.
3	Pressing down arrow, cycles down through the menu items/readings.
4	Pressing ESC returns to the analog signals menu.
5	Initial screen, item F00 with example 16.1 reading.
6	Down from configuration menu displays the analog signals menu.

Table 10.2 Analog Signal Definitions

Item ID	Meaning	Units (C90)	
		Imperial	Metric
F00	Condenser pressure 1	psi	bar
F01	Condenser pressure 2	psi	bar
F02	Ambient temperature	°F	°C
F03	Refrigerant temperature 1	°F	°C
F04	Refrigerant temperature 2	°F	°C
F10	EC Fan 1 actual speed	RPM	RPM
F11	EC Fan 1 requested speed	%	%
F12	EC Fan 1 power	kW	kW
F13	EC Fan 1 firmware version	Hex format	Hex format
F20	EC Fan 2 actual speed	RPM	RPM
F21	EC Fan 2 requested speed	%	%
F22	EC Fan 2 power	kW	kW
F23	EC Fan 2 firmware version	Hex format	Hex format
F30	EC Fan 3 actual speed	RPM	RPM
F31	EC Fan 3 requested speed	%	%
F32	EC Fan 3 power	kW	kW
F33	EC Fan 3 firmware version	Hex format	Hex format
F40	EC Fan 4 actual speed	RPM	RPM
F41	EC Fan 4 requested speed	%	%
F42	EC Fan 4 power	kW	kW
F43	EC Fan 4 firmware version	Hex format	Hex format
F50	Subcooling 1	°F	°C
F51	Subcooling 2	°F	°C
F90	Firmware Version Major		1.02.004
F91	Firmware Version Minor	—	
F92	Firmware Version Build	—	
Source: 303847 Rev. 5			

10.4.4 Active Alarms Menu

In the active alarms menu, A—, press ENT to enter the active alarm items, which displays all the active alarms of condenser, see **Table 10.3** on the next page, and **Table 10.4** on page 44, for descriptions of the system and EC fan alarms. When there are multiple alarms, the IDs display by order received/initiated with the most recent alarm displayed first. **Figure 10.10** below, shows the operation and structure of active alarms menu.

Figure 10.10 Active Alarms Menu

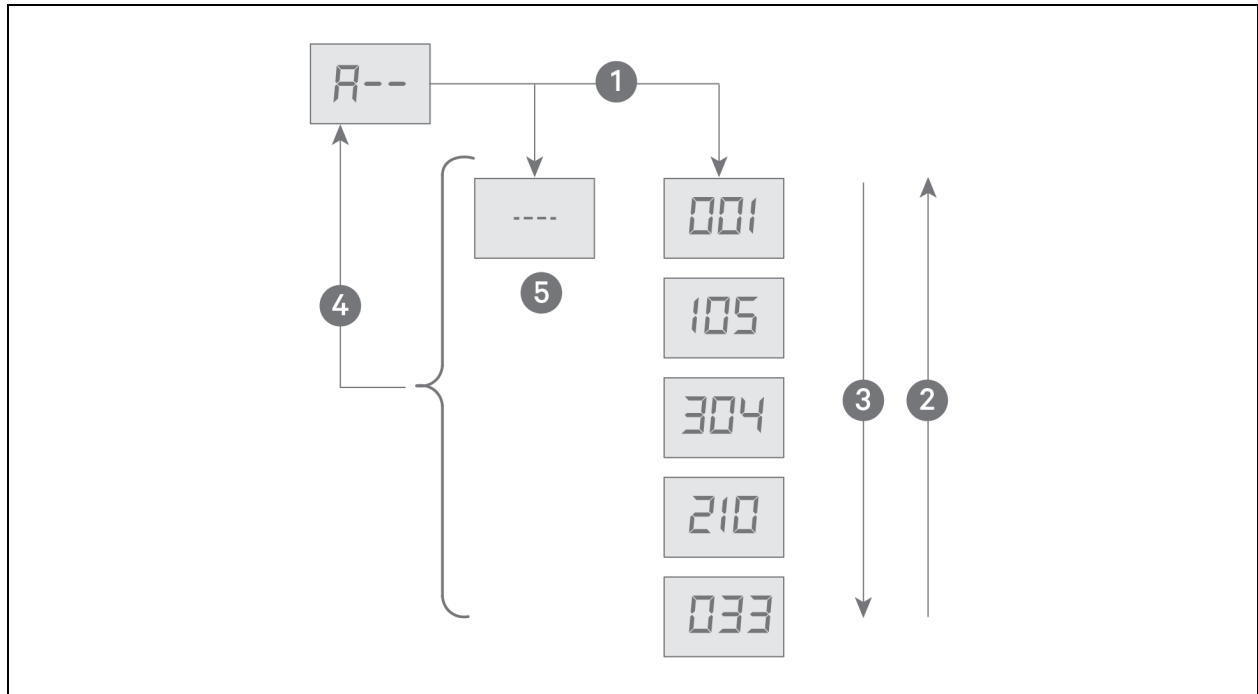

Item	Description
1	Pressing ENT displays dashes to indicate no alarm, or displays the most recent alarm ID first then in the order received/initiated. See Table 10.3 on the next page, and Table 10.4 on page 44, for a description of the alarm IDs.
2	Pressing up arrow, cycles up through the alarm IDs.
3	Pressing down arrow, cycles down through the alarm IDs.
4	Pressing ESC returns to the active alarms menu.
5	Dashes only display indicates no active alarms.

10.4.5 History Alarms Menu

In the history alarms menu, H—, press ENT to enter the history alarm items, which displays 100 history alarm records of the condenser, see **Table 10.3** on the next page, and **Table 10.4** on page 44, for descriptions of the system and EC fan alarms. The item ID is the sequence number of the history alarms. The item ID and alarm information ID display alternately. When there are no alarms, dashes --- display. You can clear the alarm history using the C98 configuration menu item. **Figure 10.11** on the next page, shows the operation and items structure.

Figure 10.11 History Alarms Menu

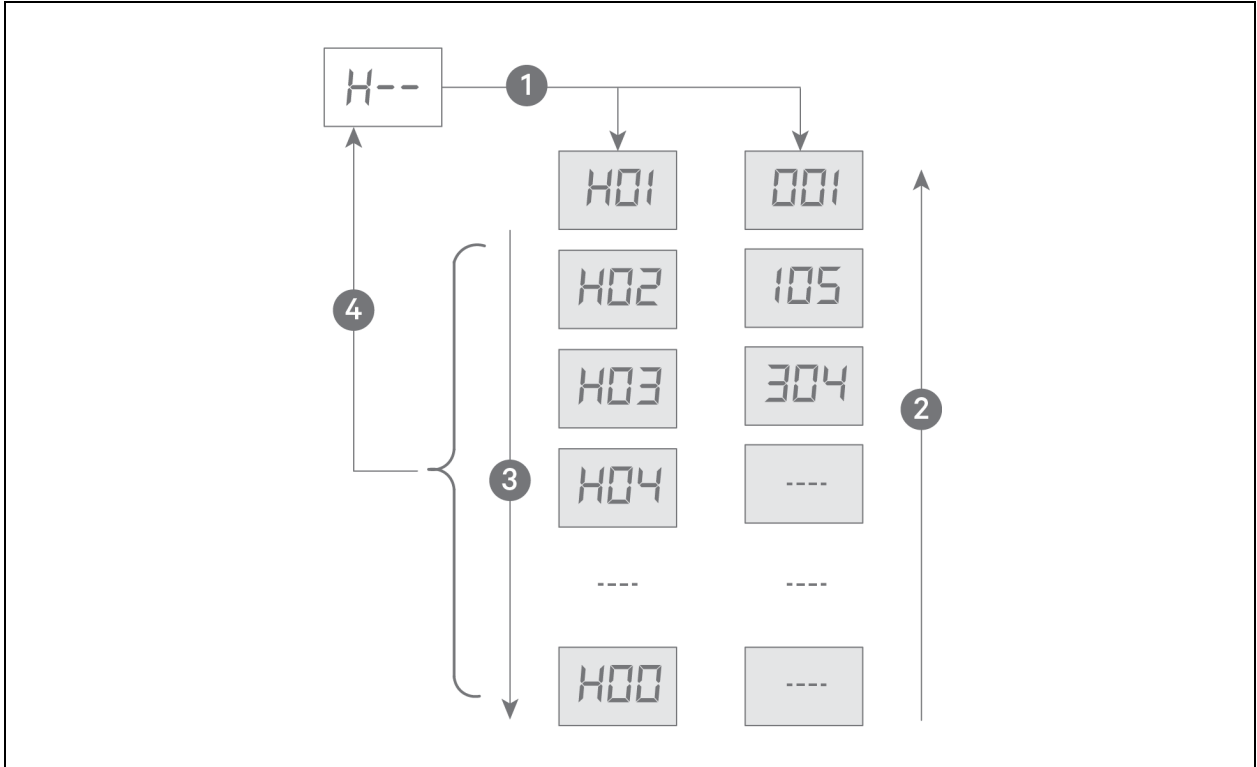

Item	Description
1	Pressing ENT displays the history alarm item(s), which alternately displays the sequence number and the alarm ID.
2	Pressing up arrow, cycles up through the sequence numbers.
3	Pressing down arrow, cycles down through the sequence numbers.
4	Pressing ESC returns to the history alarms menu.

Table 10.3 System Alarm Information

Alarm ID	Meaning	Possible Cause	Handling Method
000	CAN communication failure	Communication circuit missing or damaged.	Check communication circuit. Ignore alarm on condensers without CAN connections.
001	Ethernet communication failure	Ethernet hardware or connection failure	Ignore alarm, Ethernet connection is not present.
002	USB communication failure	USB device or file is damaged.	Replace USB device or file.
003	Data corruption	Memory chip is damaged.	Replace PCB board.
004	System error	Internal error	Reboot. If reboot fails, consult factory.

Table 10.3 System Alarm Information (continued)

Alarm ID	Meaning	Possible Cause	Handling Method
005	Remote shutdown	1. Remote shutdown signal is available. 2. TB38 is not connected.	For Cause 1, check the remote shutdown signal. For Cause 2, connect TB38.
006	Shutdown due to EC Fan alarm	All fans have failed.	Consult factory.
007	SPD alarm	SPD damaged	Replace SPD.
008	Condenser pressure Sensor 2 failure	Condenser pressure Sensor 1 damaged.	Replace condenser pressure Sensor 1.
009	Condenser pressure Sensor 2 failure	Condenser pressure Sensor 2 damaged.	Replace condenser pressure Sensor 2.
010	Condenser pressure 1 high alarm	High pressure: Fan failure, clogged coils. Low pressure: Loss of charge	High pressure alarms: Fix fan and clean coil. Low pressure alarms: Check for refrigerant leak.
011	Condenser pressure 2 high alarm		
012	Condenser pressure 1 low alarm		
013	Condenser pressure 2 low alarm		
014	EC Fan speed mode maximum must be overridden due to condenser pressure 1 high.	Condenser pressure 1 high	No action is needed.
015	EC Fan speed mode maximum must be overridden due to condenser pressure 2 high.	Condenser pressure 2 high	No action is needed.
016	Ambient temperature sensor failure	Ambient temperature sensor damaged.	Replace ambient temperature sensor.
017	Ambient temperature high alarm	Ambient temperature high	No action is needed.
018	Ambient temperature low alarm	Ambient temperature low	No action is needed.
019	Condenser temperature Sensor 2 failure	Condenser temperature Sensor 2 damaged.	Replace condenser temperature Sensor 1.
020	Condenser temperature Sensor 2 failure	Condenser temperature Sensor 2 damaged.	Replace condenser temperature Sensor 2.
021	Condenser temperature 1 high alarm	High temperature: Fan failure, clogged coils. Low temperature: Consult factory	High temperature alarms: Fix fan and clean coils. Low temperature alarms: consult factory.
022	Condenser temperature 2 high alarm		
023	Condenser temperature 1 low alarm		
024	Condenser temperature 2 low alarm		
025	EC Fan speed mode maximum must be overridden due to refrigerant temperature 1 high.	Refrigerant temperature 1 high	No action is needed.
026	EC Fan speed mode maximum must be overridden due to refrigerant temperature 2 high.	Refrigerant temperature 2 high	No action is needed.

NOTE: In Table 10.4 on the next page, (1-4) indicates the EC-fan addresses. For example, (1-4) 00 means 100 for EC Fan1, and means 200 for EC Fan2, and means 300 for EC Fan3, and means 400 for EC Fan4.

Table 10.4 EC Fan Alarm Information

Alarm ID	Meaning	Possible Cause	Handling Method
(1-4) 00	EC Fan high link current	1. EC Fan is locked. 2. EC Fan is damaged.	For cause 1, check if EC Fan is locked. For cause 2, replace EC Fan.
(1-4) 01	EC Fan drive error	EC Fan is damaged.	Replace EC Fan.
(1-4) 02	EC Fan earth to ground fault	EC Fan is damaged.	Replace EC Fan.
(1-4) 03	EC Fan electronics heat sink thermal overload	1. EC Fan is locked. 2. EC Fan is damaged. 3. Ambient temperature is too high.	For cause 1, check if EC Fan is locked. For cause 2, replace EC Fan. For cause 3, check ambient temperature.
(1-4) 04	EC Fan Hall failure	EC Fan is damaged.	Replace EC Fan.
(1-4) 05	EC Fan IGBT failure	EC Fan is damaged.	Replace EC Fan.
(1-4) 06	EC Fan line fault	Power supply abnormal	Check power supply.
(1-4) 07	EC Fan motor locked	Motor is locked.	Check if EC Fan is locked.
(1-4) 08	EC Fan motor thermal overload	1. EC Fan is locked. 2. EC Fan is damaged. 3. Ambient temperature is too high.	For cause 1, check if EC Fan is locked. For cause 2, replace EC Fan. For cause 3, check ambient temperature.
(1-4) 09	EC Fan phase failure alarm	Phase failure	Check power supply.
(1-4) 10	EC Fan specific unategorized alarm detected	Internal EC Fan issue	Reboot condenser if fans not running. If alarm persists and fans not running, replace fan.
(1-4) 11	EC Fan specific unategorized warning detected		
(1-4) 12	EC Fan electronics high temperature condition	1. EC Fan is locked. 2. EC Fan is damaged. 3. Ambient temperature is too high.	For cause 1, check if EC Fan is locked. For cause 2, replace EC Fan. For cause 3, check ambient temperature.
(1-4) 13	EC Fan high link voltage	1. EC Fan input power supply high voltage 2. EC Fan is damaged.	For cause 1, measure power supply voltage and check if the voltage is normal.
(1-4) 14	EC Fan low link voltage	1. EC Fan input power supply low voltage 2. EC Fan detection error	For cause 2, replace EC Fan.

Table 10.4 EC Fan Alarm Information (continued)

Alarm ID	Meaning	Possible Cause	Handling Method
(1-4) 15	EC Fan 485 communication failure	1. Communication between EC Fan and PCB board failure 2. EC Fan 485 communication failure 3. Board has problems. 4. EC fan not receiving power.	For cause 1, check EC Fan communication circuit. For cause 2, replace EC Fan. For cause 3, replace PCB board. For cause 4, check fan model is not set for 0, check that the contactor for the particular fan is energized, and check fan fuses.
(1-4) 16	EC vibration warning	Fan blade imbalance	Check ice has not formed on blades. Check to verify mounting bolts and secure. Replace fan.
(1-4) 17	EC Fan bearing fail	Fan bearings have failed.	Replace fan.

This page intentionally left blank

11 Maintenance



WARNING! Arc flash and electric shock hazard. Open all local and remote electric power supply disconnect switches, verify with a voltmeter that power is Off and wear appropriate, OSHA-approved personal protective equipment (PPE) per NFPA 70E before working within the electric control enclosure. Failure to comply can cause serious injury or death. Customer must provide earth ground to unit, per NEC, CEC and local codes, as applicable. Before proceeding with installation, read all instructions, verify that all the parts are included and check the nameplate to be sure the voltage matches available utility power. The Vertiv™ Liebert® iCOM™ controller does not isolate power from the unit, even in the Unit Off mode. Some internal components require and receive power even during the Unit Off mode of the Liebert® iCOM™ controller. The only way to ensure that there is NO voltage inside the unit is to install and open a remote disconnect switch. Refer to unit electrical schematic. Follow all local codes.



WARNING! Risk of electric shock. Can cause equipment damage, injury or death. Open all local and remote electric power supply disconnect switches and verify with a voltmeter that power is off before working within any electric connection enclosures. Service and maintenance work must be performed only by properly trained and qualified personnel and in accordance with applicable regulations and manufacturers' specifications. Opening or removing the covers to any equipment may expose personnel to lethal voltages within the unit even when it is apparently not operating and the input wiring is disconnected from the electrical source.



WARNING! Risk of electric shock. Can cause serious injury or death. The Liebert® iCOM™ microprocessor does not isolate power from the unit, even in the Unit Off mode. Some internal components require and receive power even during the "unit off" mode of the Liebert® iCOM™ control. Open all local and remote electric power disconnect switches and verify with a voltmeter that power is Off before working on any component of the system.



WARNING! Risk of contact with high speed rotating fan blades. Can cause serious injury or death. Open all local and remote electric power supply disconnect switches, verify with a voltmeter that power is off, and verify that all fan blades have stopped rotating before working in the unit cabinet or on the fan assembly. If control voltage is applied, the fan motor can restart without warning after a power failure. Do not operate the unit with any or all cabinet panels removed.

- Good maintenance practices are essential to minimizing operation costs and maximizing product life.
- Read and follow monthly and semi-annual maintenance schedules included in this manual. These MINIMUM maintenance intervals may need to be more frequent based on site specific conditions.
- We recommend the use of trained and authorized service personnel, extended service contracts, and factory specified replacement parts. Contact your Vertiv sales representative.

11.1 General Maintenance

Record the unit model number, serial number, and voltage. Please record those numbers in the spaces below.

- **Model Number** _____
- **Serial Number** _____
- **Voltage/Phase/Frequency** _____

Periodic attention is necessary for continued satisfactory operation of your unit. Restricted air flow through the condenser coil, reduced airflow from non-functioning fans, and low refrigerant system charge levels will reduce the operating efficiency of the unit and can result in high condensing temperatures and loss of cooling. In winter, do not permit snow to accumulate around the sides or underneath the condenser coil.

Monthly and semi-annual inspections and maintenance are recommended for proper system operation. Use copies of [Preventive Maintenance Checklist](#) on page 61, for each of these inspections.

11.2 Condenser Cleaning - Standard Coil

Keeping the outdoor condenser coils clean is an important factor in maintaining peak efficiency, reliability, and long life of the equipment. The unit will operate more efficiently with frequent cleanings. If you delay cleaning until heavy build up occurs, head pressure problems with the evaporator units can develop.

11.2.1 When to Clean the Condenser Coil

Normal conditions typically dictate cleaning twice a year, in spring and fall. On-site or area conditions such as cottonwood trees, construction, etc., can increase cleaning frequency. On your standard monthly preventive maintenance schedule, we recommend a visual inspection of the coil to monitor conditions.

11.2.2 What to Use to Clean the Condenser Coil

NOTICE

Risk of improper cleaning agent selection, including non-base paint solvents. Can cause building and equipment damage and loss of refrigerant charge.

Using acid based or sodium hydroxide based cleaners can damage the coil and cause a loss of charge. This could cause equipment damage as well as damage to the surrounding structure.

- Start with removing dirt, leaves, fibers, etc. with a soft brush or vacuum cleaner fitted with a soft brush attachment.
- Do not use a wire brush or scrape the coil with a metal vacuum hose. The best overall condenser coil cleaner is plain water.
- If the coil is maintained and cleaned at regular intervals, water is sufficient to remove dirt and debris from the fins.
- Water pressure from a garden hose and sprayer usually works well. If a pressure washer is used, make sure that the equipment is set to a lower pressure setting and that the nozzle is set to the fan spray, not stream. Otherwise, damage to the fins could result.
- If a cleaner is required, we recommend using a neutral cleaner, neither acidic nor base. Acid type cleaners can damage the coil fins and surrounding areas. Many sites do not allow the use of acidic cleaners for environmental reasons.

11.2.3 Cleaning the Condenser Coil

1. Clean the area around the condenser to ensure leaves, grass, or loose debris will not be blown into the coil.
2. Turn off the electrical power to the unit using the lockout system.
3. Remove access door panels located on the left or right side of the condenser to gain access to the coil(s) that are to be cleaned.
4. Remove surface dirt with a vacuum cleaner, preferably with a brush or other soft attachment rather than a metal tube.
5. Flush the outside of the coil with water to loosen residue dirt. Allow the water to soak for 10 to 20 minutes to loosen surface residue. Rinse only with warm water (< 100°F).

NOTE: Do not use any chemicals or commercial coil cleaner to clean micro channel exchangers as this may cause corrosion.

6. Remove dirt and water with a vacuum cleaner, preferably with a brush or other soft attachment rather than a metal tube.
7. Inspect the coil to make sure that it is draining correctly.
8. Rinse the coil thoroughly again.
9. Vacuum the surface of the coil again and remove any excess dirt and water.
10. Use compressed air blown from the inside out to dry out the coil.
11. Do not impact the coil with the vacuum tube or air nozzle.
12. Repeat the above steps until the coil is completely clean.
 - a. **Do not hit the coil face or header with the hose.** This type of damage will impact the coil performance and operation.
13. Apply low pressure air to the coil face and vacuum out the residual water from the coil to speed up drying and prevent pooling.
 - a. Low pressure spray will reduce possible impact damage to the coil.
14. Close the access panel doors to the coil section.
15. Turn on the electrical power to the unit and run the system.

NOTE: Spraying the coil from the outside repeatedly can push a majority of the dirt to the inner section of the fins and continue to restrict air flow. Keep in mind you may not have the luxury of shutting the unit(s) down for an extended time. A scheduled shutdown with the operator may be in order.

11.3 Condenser Cleaning - E-coat Coil

A scheduled and documented QUARTERLY cleaning procedure is REQUIRED for all HVAC/R equipment coated with Modine coil and/or cabinet protection.

11.3.1 General Instructions: (detailed instructions to follow)

Remove surface loaded fibers – Coils Only

Surface loaded fibers or dirt should be removed prior to cleaning and/or water rinse to prevent further restriction of airflow. If unable to back wash the side of the coil opposite that of the coils entering air side, then surface loaded fibers or dirt should be removed with a vacuum cleaner. If a vacuum cleaner is not available, a soft non-metallic bristle brush may be used while brushing the fins, typically vertically for RTPF coils. Coil surfaces can be easily damaged (fin edges bent over) if the brush is applied across the fins.

NOTE: Use of a water stream, such as a garden hose, against a surface loaded coil will drive the fibers, dirt, and salts into the coil. This will make cleaning efforts more difficult. Surface loaded fibers must be completely removed prior to completing low velocity cleaning and water rinses.

Required quarterly cleaning and chloride removal of Modine coated equipment (coil and cabinet surfaces)

Quarterly cleaning is required to maintain warranty coverage and is essential to maintain the life of a Modine coated coil and cabinet. Coil and cabinet cleaning shall be part of the unit's regularly scheduled maintenance procedures.

Failure to clean a Modine coated coil or cabinet on the prescribed quarterly cycle will void the warranty and may result in reduced efficiency and durability in the environment.

A routine two-step quarterly coil cleaning is required to maintain warranty. Step one is to clean the coil with the below approved coil cleaner (see approved products listed in [Recommended Coil Cleaners](#) below. Step two is to use the approved salt/chloride remover listed in [Recommended Chloride Remover](#) below to dissolve soluble salts and revitalize the unit. It is very important when cleaning and/or rinsing not to exceed 1300°F and potable water pressure is less than 100 psig to avoid damaging the unit and coil fin edges.

For routine quarterly cabinet cleaning, first clean the cabinet using a rag or sponge with a mild dish soap such as Dawn to remove dirt and/or contaminants. Once the cabinet surfaces have been cleaned, a thorough rinse should be completed. After the cabinet has been cleaned, use the approved chloride remover listed in [Recommended Chloride Remover](#) below to remove soluble salts and revitalize the units cabinetry. This is then followed by a thorough water rinse. It is very important when cleaning and/or rinsing not to exceed 1300°F and potable water pressure is less than 100 psig to avoid damaging the unit.

Recommended Coil Cleaners

The following coil cleaners, assuming it is used in accordance with the manufacturer's directions on the container for proper mixing and cleaning, have been approved for use on Modine coated coils to remove mold, mildew, dust, soot, greasy residue, lint, and other particulate. Never use any cleaners that are not approved.

Table 11.1 Step 1 of 2

Coil Cleaner
GulfCoat Coil Cleaner

Recommended Chloride Remover

The following chloride remover, assuming it is used in accordance with the manufacturer's directions on the container for proper mixing, has been approved for use on Modine coated coils and cabinets to remove chlorides/salts and sulfates. Never use any chloride removers that are not approved.

Table 11.2 Step 2 of 2

Chloride Remover
CHLOR*RID Concentrate

Harsh Chemical and Acid Cleaners

Harsh chemicals, household bleach or acid cleaners should not be used to clean outdoor or indoor Modine coated coils and/or cabinets. These cleaners can be very difficult to rinse out of the coil and can accelerate the corrosion attack of the coil.

High Velocity Water or Compressed Air

High velocity water from a pressure washer or compressed air should only be used at a very low pressure, (< 100 psi), to prevent fin and/or coil damages. The force of the water or air jet may bend the fin edges and increase air side pressure drop. Reduced unit performance or nuisance unit shutdowns may occur.

11.3.2 Detailed Instructions

Scope

The Warranty Protection plan consists of a two-step process. Step 1 is to clean the coils and step 2 is to remove the salts/chlorides.

The coils are to be thoroughly cleaned using an approved coil cleaner as listed above in **Table 11.1** on the previous page. Once cleaned, they will then need to have the chlorides/salts removed by using preferred chloride remover as listed in **Table 11.2** on the previous page.

Warranty Protection Step 1 of 2

Complete the coil cleaning following these steps.

1. Ensure that the power to the unit is off and locked out.
2. Clean the area around the unit, if needed, to ensure leaves, grass or loose debris will not be blown into the coil.
3. Remove panels or tops as required to gain access to the coil(s) to be cleaned.
4. Using a pump up sprayer, fill to the appropriate level with potable water and add the correct amount of approved cleaner as per manufacture instructions leaving room for the pump plunger to be reinserted.

NOTE: Coils should always be cleaned/back flushed, opposite of airflow to prevent impacting the dirt into the coil.

5. If the coils have heavy dirt, fibers, grass, leaves, etc. on the interior or exterior face areas, a vacuum and brush should be used to remove those surface contaminants prior to applying cleaner. The interior floor, drain tray or pan areas should also be vacuumed.
6. Apply the mixed cleaner to coil surfaces using a pressurized pump up sprayer maintaining a good rate of pressure and at a medium size nozzle spray, (not a solid stream and not a wide fan but somewhere in the middle). Work in sections/panels ensuring that all areas are covered and kept wetted.
7. Apply the cleaner to unit interior air exiting side coil surfaces first. Work in sections/panels moving side to side and from top to bottom.
8. Generously soak coils by spraying cleaner directly on and into the fin pack section to be cleaned and allow the cleaning solution to soak for 5 to 10 minutes.
9. Using pressurized potable water, (< 100 psi), rinse the coils and continue to always work in sections/panels. Start at the top of the coil and slowly move vertically downward to the bottom. Then, staying in the same vertical area, slowly move back up to the top where you started. Now move over slightly overlapping the area just completed and repeat above. Continue until all coil areas on the inside of the unit have been rinsed.
10. Complete steps 5 - 9 for the exterior air entering side of the coils.
11. Final rinse – Now complete a quick rinse of both sides of the coil including the headers, piping, u-bends and hairpins.
12. If the coil has a drain pan or unit floor that is holding rinse water or cleaner, extra time and attention will need to be taken in those areas to ensure a proper rinse has been completed.

Warranty Protection Step 2 of 2

Complete the coil chloride (salt) removal following these steps.

1. CHLOR*RID is a concentrate to be used for both normal inland applications at a 100:1 mix ratio OR for severe coastal applications 50:1 mix ratio with potable water, (2.56 ounces of CHLOR*RID to 1 gallon of water). Using a pump up sprayer, fill to the appropriate level with potable water and add the correct amount of CHLOR*RID salt remover leaving room for the pump plunger to be reinserted.
2. Apply CHLOR*RID to all external coil surfaces using a pressurized pump up sprayer, maintaining a good rate of pressure, and at a medium size nozzle spray, (not a solid stream and not a wide fan but somewhere in the middle). Work in sections/panels ensuring that all areas are covered and kept wetted.
3. Generously soak coils by spraying CHLOR*RID directly on and into the fin pack section. Let stand for 5 to 10 minutes keeping the area wetted. Do not allow to dry before rinsing.
4. Using pressurized potable water, (< 100 psi), rinse the CHLOR*RID and dissolved chlorides/salts off of the coils continuing to always work in sections/panels.
5. Starting at the top of the coil, begin rinsing the coil from side to side until you reach the bottom. Repeat as many times as is necessary to ensure all coil sections/panels have been completed and are thoroughly rinsed.
6. Reinstall all panels and tops that were removed.

Complete the cabinet cleaning and chloride removal following these steps.

1. Ensure that the power to the unit is off and locked out.
2. Clean the cabinet using a rag or sponge with a mild dish soap such as Dawn to remove dirt and/or contaminants.
3. Once the cabinet surfaces have been cleaned, a thorough rinse should be completed.
4. After the cabinet has been cleaned, use the approved chloride remover listed in [Recommended Chloride Remover](#) on page 50 to remove soluble salts and revitalize the unit's cabinetry.

NOTE: It is very important when cleaning and/or rinsing not to exceed 1,300°F and potable water pressure is less than 100 psig to avoid damaging the unit.

5. Final rinse – Now complete a quick rinse of all cabinetry and coils to ensure a proper final rinse.
6. Notify the proper personnel that the equipment may now be turned backed on.

11.4 Replacing the Condenser EC Fan



WARNING! Arc flash and electric shock hazard. Open all local and remote electric power supply disconnect switches, verify with a voltmeter that power is Off and wear appropriate, OSHA-approved personal protective equipment (PPE) per NFPA 70E before working within the electric control enclosure. Failure to comply can cause serious injury or death. Customer must provide earth ground to unit, per NEC, CEC and local codes, as applicable. Before proceeding with installation, read all instructions, verify that all the parts are included and check the nameplate to be sure the voltage matches available utility power. The Vertiv™ Liebert® iCOM™ controller does not isolate power from the unit, even in the Unit Off mode. Some internal components require and receive power even during the Unit Off mode of the Liebert® iCOM™ controller. The only way to ensure that there is NO voltage inside the unit is to install and open a remote disconnect switch. Refer to unit electrical schematic. Follow all local codes.



WARNING! Risk of electric shock. Can cause serious injury or death. Open all local and remote electric power supply disconnect switches and verify with a voltmeter that power is off before working within the fan motor electric connection enclosures. Fan motor controls can maintain an electric charge for 10 minutes after power is disconnected. Wait 10 minutes after power is verified as off before working within the fan electric control/connection enclosures. Use only fully trained and qualified HVAC technicians to perform maintenance on the fans.



WARNING! Risk of contact with high speed rotating fan blades. Can cause serious injury or death. Open all local and remote electric power supply disconnect switches, verify with a voltmeter that power is off, and verify that all fan blades have stopped rotating before working in the unit cabinet or on the fan assembly. If control voltage is applied, the fan motor can restart without warning after a power failure. Do not operate the unit with any or all cabinet panels removed.



CAUTION: Risk of contact with hot surfaces. Can cause injury. The electronics housing, humidifier components, compressor, refrigerant discharge lines, fan motor, and some electrical components are extremely hot during unit operation. Allow sufficient time for them to cool to a touch safe temperature before working within the unit cabinet. Use extreme caution and wear appropriate, OSHA-approved PPE when working on or near hot components.



CAUTION: Risk of improper moving, lifting and handling. Can cause equipment damage or injury. Only properly trained and qualified personnel should work on this equipment. Condenser fan modules weigh in excess of 115 lb (52.2 kg). Use proper lifting techniques and wear appropriate, OSHA-approved PPE to avoid injury and dropping the fan module during removal. Equipment used in handling/lifting, and/or installing the fan assembly must meet OSHA requirements. Use handling/lifting equipment rated for the weight of the fan assembly. Use ladders rated for the weight of the fan assembly and technicians if used during installation. Refer to handling/lifting, and/or installation equipment operating manual for manufacturer's safety requirements and operating procedures.

NOTE: If at any time a parameter is entered and the condenser display does not show 888 or if the display shows Err, re-enter the parameter. If the display still shows Err after ENT is pressed, power cycle the control board by unplugging P24, waiting 15 seconds and plugging P24 back in. Contact the factory if the parameter still displays Err after ENT is pressed.

11.4.1 Fan Replacement

1. Turn power off to the unit using the disconnect.
2. Use a voltmeter to verify that voltage is no longer present at the unit. Wait a minimum of 10 minutes to allow the EC fan capacitors to discharge before proceeding.
3. Remove the fan cover, disconnect electrical connections internal to the EC fan and remove the cable glands from the EC fan to be replaced.
4. Remove hardware that attaches the EC fan to the condenser.
5. Use lifting equipment or an adequate number of personnel to remove the EC fan from the condenser.

NOTE: A spreader bar may be required for the lifting equipment if only one technician is performing the fan replacement.

6. Install a spreader bar over the new EC fan if only one technician is performing the fan replacement.
7. Verify that the wire harness on the new EC fan is secured out of the way before lifting the fan.
8. Verify that the lifting cable/chains are not in contact with fan blades before lifting the new fan into place on the condenser.
9. Install the new fan in the condenser and connect the mounting hardware.
10. Verify that the fan blades rotate freely when installed in unit.
11. Install the new cable glands included with the new EC fan. Torque for the cable glands is:
 - 630mm and 710mm fans: 19.5 to 24.75 in-lb (2.2 to 2.8 Nm)
 - 800mm fans: 32.75 to 38 in-lb (3.7 to 4.3Nm)

Dispose of the old cable glands once the new glands are installed.

12. Add a compression nut to the wire—Do not tighten the nut.
13. Reconnect the wiring to the proper terminals.
 - The torque for the electrical terminals is 11.5 in-lb (1.3 Nm). Tighten the compression nut to a torque of 22 in-lb (2.5 Nm).
14. With the PCB powered, the board display should read *FOO*.
15. Press the **ESC** button.
16. Press the **UP**-arrow button once:
 - If *P-* is displayed, see [P--Menu Programming](#) below.
 - if *P-* is not displayed, see [Manual Fan Addressing \(No P-- Menu\)](#) on the facing page.
 - Once set-up is complete, see [Verifying the Fan Address](#) on page 57.

NOTE: The complete list of P--, C--, and F-- parameters is located inside the lid of the electrical box panel.

11.4.2 P--Menu Programming

1. If *P-* is displayed, press the ENT button to enter the *P-* Menu.

The *P-* Menu allows compact setup/preparation of the condenser in the factory or in the field. Use the functions described in **Table 11.3** on the facing page, to establish a default control configuration for the board.

Table 11.3 P-- Menu Items and Definitions

Item ID	Meaning	Default	Notes
P01	Enter Preparation Mode	0	Setting this value to 1 enables preparation mode. All other P--menu items are disabled until this value is 1. Note that control operations may be affected during preparation mode, therefore the cooling unit should be off. Setting this value back to 0 creates new default values based upon selections in this menu. After default values are established, the board exits preparation mode and reboots.
P02	Automatic VSD Configuration	1	This item should only be used to address the VSDs for the unit. The value entered indicates the model of the VSD: 1 – EBM 2 – Ziehl-Abegg 3 – Fans Tech 4 – Rosenberg 6 – Multi-wing All fans must be the same model to use this parameter. When <i>ENT</i> is pressed, the board will operate and power contactors for the VSDs and assign ModBus addresses. This procedure may take up to 5 minutes to complete.
P03	Refrigerant Type	2	1 = R22 2 = R407C 3 = R410A
P04	Number of Circuits	1	1 = Single Circuit 2 = Dual Circuit
P05	Liebert® Lee Temp Option	0	0 = No Liebert® Lee-Temp installed 1 = Liebert® Lee-Temp installed
P06	Condenser	1	0 = Small

NOTE: Once set-up is complete, see [Verifying the Fan Address](#) on page 57.

11.4.3 Manual Fan Addressing (No P-- Menu)

1. Unplug all fans before making changes to the fan configuration menu. If a fan has been replaced or is being re-addressed, keep it unplugged until the fan type has been configured and it is ready to be addressed (Step 15).
2. Turn the power on.
3. The control board flashes *FOO* on the display when it has completed its boot cycle.
4. Press the ESC button.
5. Use the **UP** or **DOWN** arrows until *C--* is on display.
6. Press the **ENT** button.
7. Use the **UP** or **DOWN** arrows until *C03* is on display.
8. Press the **ENT** button.

9. Use the **UP** or **DOWN** arrows to select one of five options:

Table 11.4 Configuration Code Values

Configuration Code	Fan #	Value
C03	Fan 1	0 = No Fan
C04	Fan 2	1 = EBM Papst
C05	Fan 3	2 = Ziehl-Abegg
C06	Fan 4	4 = Rosenberg
		6 = Multi-wing

10. Press the **ENT** button.
11. If the new value is entered into the control board, the display flashes "888."
12. Press the **ESC** button for C03 to be shown on the display.
13. Repeat steps 4 through 11 for C04, C05, and C06 setting them to 0, No Fan.
14. Unplug the power connector to the Condenser controller board (P24).
15. Reconnect only the fan to be addressed, to P23 (on the control board), Fan 1's connection. Make sure to only plug in one fan at a time during this process or you may corrupt the settings in the other fans. Plugs listed below:
- P23 = Fan 1
 - P27 = Fan 2
 - P28 = Fan 3
 - P29 = Fan 4
16. Wait 30 seconds (60 seconds when using Multi-wing).
17. Power the condenser board back up and wait for the F00 to be displayed.
18. Use the **UP** or **DOWN** arrows to select one of the following parameters.
- The correct parameter depends on the supplier of the fan that will be addressed.
- C00—EBM Papst fan
 - C01—Ziehl-Abegg fan
 - C29 - Rosenberg fan
 - C30 = Multi-wing
19. Press the **ENT** button.
20. Use the **UP** or **DOWN** arrows to the correct fan address number. Fan 1 should be 1 (fan closest to electric panel end). Fan 2 should be 2, etc.
21. Press the **ENT** button. The display flashes 888 when the command is accepted.
22. Press the **ESC** button for the parameter to be shown on the display.
23. Repeat steps 7 through 22 for the rest of the fans that need to be addressed such that only the fan to be addressed is connected and it is plugged into the fan 1 output P23.
24. Once addressing is complete, unplug all fans so they can be connected to the correct output after configuration (Step 28).
25. Use the C3-C6 commands as shown in Step 9 so all installed fans are set to the correct matching brand.
26. Unplug the power plug, P24, from the control board.
27. Wait 30 seconds.

28. Plug all the contactor output plugs back into the board in their correct positions.
29. Plug P24 back into the control board.
30. Once the control board has completed its boot cycle and all the contactors are energized, wait 5 seconds.
31. Press the **ESC** button.
32. Use the **UP** or **DOWN** arrows until A-- is on the display.
33. Press **ENT** button.
34. Use the **UP** or **DOWN** arrows to see if any of the following errors are shown.
 - a. 115: Unable to communicate with Fan 1.
 - b. 215: Unable to communicate with Fan 2.
 - c. 315: Unable to communicate with Fan 3.
 - d. 415: Unable to communicate with Fan 4.
35. If any of these errors appear, check the communication wiring at the problem fan and the fan before it.
36. If the wiring is correct and properly wired to the terminal, repeat the fan addressing procedure in steps 14 through 34.
37. If none of the errors listed in step 34 are displayed, press the **ESC** button.

11.4.4 Verifying the Fan Address

To verify that each fan has a unique address:

1. Use the UP or DOWN arrow button until C-- displays.
2. Press the ENT button.
3. In the Manual/System Control Selection parameter use the UP or DOWN arrow button until C24 displays.
4. In the Manual Control configuration parameter, press the ENT button.
5. Use the UP or DOWN arrow button to select 0.
6. Press the ENT button. The display reads 888 if the command is accepted.
7. Press the ESC button to display C24.
8. Use the UP or DOWN arrow button until C34 displays.
9. Press ENT button. If Fan 1 is running, the fans speed should display in terms of percentage of full speed. If Fan 1 is not running, 0.00 should display.
10. Use the UP or DOWN arrow button to enter 100% speed.
11. Press the ENT button. The display reads 888 if the command is accepted.
 - Fan 1 should speed up to 100%, and all the other fans should stay the same speed.
12. If Fan 1 is not running or if any of the other fans also speed up to 100%, steps 15 through 22 of [Replacing the Condenser EC Fan](#) on page 53, must be repeated.
13. Press the ESC button for the parameter to be shown on the display.
14. Repeat steps 3 through 8 for the rest of the fans, if present.
 - C35: for Fan 2.
 - C36: for Fan 3.
 - C37: for Fan 4.

NOTE: All fans should be at 100% speed.

15. Use the UP or DOWN arrow button until C24 displays.
16. Press the ENT button.

17. In the System Control configuration parameter, use the UP or DOWN arrow button to select 1.
18. Press the ENT button. The display reads 888 if the command is accepted.
19. Press the ESC button to display C24. All fans should return to a normal speed based on the pressure input and the state of indoor unit's compressor.

11.5 Replacing the Premium Efficiency Control Board

Use these steps to replace the Premium Efficiency Control Board in the condenser.



WARNING! Arc flash and electric shock hazard. Open all local and remote electric power supply disconnect switches, verify with a voltmeter that power is Off and wear appropriate, OSHA-approved personal protective equipment (PPE) per NFPA 70E before working within the electric control enclosure. Failure to comply can cause serious injury or death. Customer must provide earth ground to unit, per NEC, CEC and local codes, as applicable. Before proceeding with installation, read all instructions, verify that all the parts are included and check the nameplate to be sure the voltage matches available utility power. The Vertiv™ Liebert® iCOM™ controller does not isolate power from the unit, even in the Unit Off mode. Some internal components require and receive power even during the Unit Off mode of the Liebert® iCOM™ controller. The only way to ensure that there is NO voltage inside the unit is to install and open a remote disconnect switch. Refer to unit electrical schematic. Follow all local codes.

11.5.1 Preparing to Replace the Board

1. Verify that the following jumpers are installed on the new board (see **Figure 11.1** on the facing page):
 - Jumper at J4 and J6 on Pins 2 and 3.
 - Jumper on J2.
 - Jumper on J5 on Pins 1 and 2.
2. Locate the latest revision of the HMI parameters label, 303847P1, included with the new control board.

NOTE: In Figure 11.1 on the facing page, J6 is the CANbus termination jumper. J4 is the RS485 service termination jumper. If the condenser is the last device in the CANbus communication line, the jumper must be placed between Pins 1 and 2 of J6. If the condenser is not the last device in the CANbus communication line, the jumpers on J6 must be placed on Pins 2 and 3. If the jumper is not in the correct positions, CANbus communication errors may occur. The jumper on J4 will always be placed between Pins 1 and 2.

NOTE: In Figure 11.1 on the facing page, a jumper must be present at J2. If a jumper is not present, the control board will not boot properly during power start-up.

Figure 11.1 Jumper Locations on Control Board

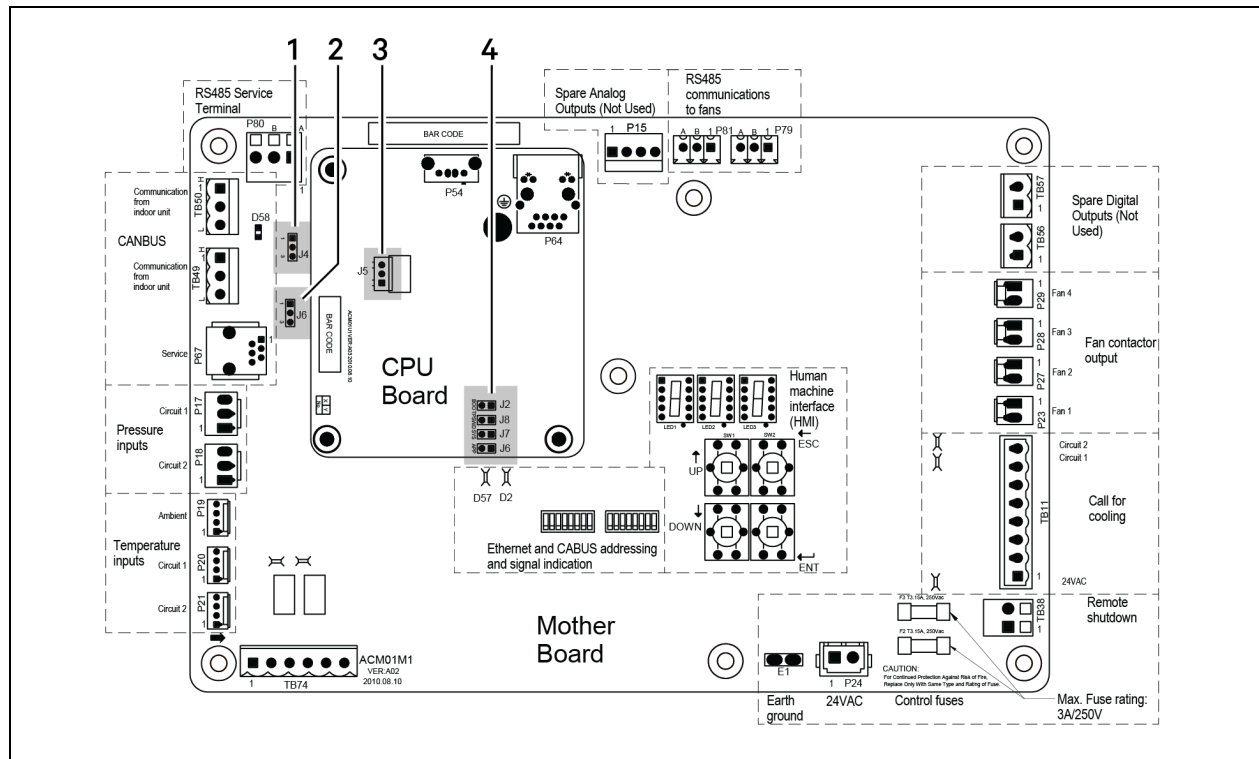

Item	Description
1	J4, RS485 service termination jumper
2	J6, CANbus termination jumper
3	J5
4	J2

11.5.2 Installing the Replacement Board



WARNING! Arc flash and electric shock hazard. Open all local and remote electric power supply disconnect switches, verify with a voltmeter that power is Off and wear appropriate, OSHA-approved personal protective equipment (PPE) per NFPA 70E before working within the electric control enclosure. Failure to comply can cause serious injury or death. Customer must provide earth ground to unit, per NEC, CEC and local codes, as applicable. Before proceeding with installation, read all instructions, verify that all the parts are included and check the nameplate to be sure the voltage matches available utility power. The Vertiv™ Liebert® iCOM™ controller does not isolate power from the unit, even in the Unit Off mode. Some internal components require and receive power even during the Unit Off mode of the Liebert® iCOM™ controller. The only way to ensure that there is NO voltage inside the unit is to install and open a remote disconnect switch. Refer to unit electrical schematic. Follow all local codes.

1. Turn Off the disconnect switch on the condenser enclosure cover.
2. Open the control enclosure cover.

3. Manually turn On the disconnect switch.

NOTE: Power is On and a shock hazard exists with exposure to hazardous voltage components.

4. If the board can still be powered up and has a display, record the parameter settings.
 - To obtain parameters go to the C-- menu and press the **UP** or DOWN arrow button to read and record the values for C03-09 and C27.
5. Record all of the DIP switch positions for the CANbus DIP switch package. Retain these for setting up the new board.
6. Record the positions of the jumpers for J2, J4, J5, and J6 on control board in the unit. Retain these for setting up the new board.
7. Disconnect power from the condenser by turning Off the main disconnect switch.
8. Use a voltmeter to verify that voltage is no longer present in the unit.
9. Remove the plugs and field installed wires from the old board. Note the polarity for the CANbus wiring going to P49 and P50, if present.
10. Mark wires P49-1, P49-3, etc, if they are not already marked.
11. Remove the mechanical fasteners holding the control board in place and remove the old control board.
12. Install the new control board using the fasteners removed in step 11.
13. Reattach the plugs. Refer to the hot stamps on the wire harnesses that correspond to the correct plug on the board. Verify that the plugs are installed properly.
14. Change the CANbus DIP switch positions so they match the control board that was removed. If the condenser is the second condenser on the CANbus communication line, set Position 1 of the CANbus DIP switch from On to Off.
15. Change the jumper positions for J2, J4, J5, and J6 to match the control board that was removed. If the condenser is the last device on the CANbus communication line, move the jumper at J6 from Pins 2 and 3 to Pins 1 and 2 (see **Figure 11.1** on the previous page).
16. Power up the unit.
17. Change the parameters to match the parameters from the control board that was removed if they were obtained from the old board in step 4. See step 18 if the parameters were unavailable.
18. If the old board parameters were unavailable, use the new HMI label included in kit to obtain the proper settings. Parameters C03, C04, C05, and C06 must be programmed with the proper EC fan supplier used on the unit.
19. Address the fans (refer to [Replacing the Condenser EC Fan](#) on page 53).
20. Compare the HMI label on the unit with the latest revision.
 - If there are differences, clean and dry the surface of the old HMI label; attach the new label on top of the old label, covering the old label with the new one.
21. Verify that the control board is reading pressure and temperature.
22. Verify that there are no communication alarms with the fans or with the cooling unit the condenser is serving.
23. Verify proper fan operation by adjusting the cooling unit that this condenser serves so that it calls for cooling.

12 Preventive Maintenance Checklist

Source: DPN003119, Rev 1

Inspection Date	Job Name
Indoor Unit Model #	Indoor Unit Serial Number #
Condensing Unit Model #	Condensing Unit Serial #
Room Temperature/Humidity °	% Ambient Temperature °

Not all units will have all components. To determine your unit's configuration, compare the Indoor Unit Model # above and the information in the Components and Nomenclature section.

Good maintenance practices are essential to minimizing operation cost and maximizing product life. Read and follow all applicable maintenance checks listed below. At a minimum, these checks should be performed semi-annually. However, maintenance intervals may need to be more frequent based on site specific conditions. Review the unit user manual for further information on unit operation. We recommend the use of trained and authorized service personnel, extended service contracts, and factory certified replacement parts. Contact your local sales representative for more details.

Check all that apply:

- Clean coil and free of debris.
- Free fans of debris.
- Check security mount fans.
- Check that motor bearings are in good condition.
- Check all refrigerant lines for vibration isolation. Support as necessary.
- Check/re-torque wire connections.
- Check contactors for pitting. Replace if pitted.
- Check surge protection device status indicator lights (if equipped).
- Verify operation sequence/setpoints.
- Check refrigerant lines for signs of leaks. Repair as found.
- Charge verification:
 - a. Outdoor ambient temperature _____
 - b. Subcooling _____
 - c. Indoor unit return air temperature _____
 - d. Sight glass level (if Vertiv™ Liebert® Lee-Temp or pumped refrigerant) _____

Check the motor amp draw.

#1	L1 _____	L2 _____	L3 _____
#2	L1 _____	L2 _____	L3 _____
#3	L1 _____	L2 _____	L3 _____
#4	L1 _____	L2 _____	L3 _____
#5	L1 _____	L2 _____	L3 _____
#6	L1 _____	L2 _____	L3 _____
#7	L1 _____	L2 _____	L3 _____
#8	L1 _____	L2 _____	L3 _____
#9	L1 _____	L2 _____	L3 _____
#10	L1 _____	L2 _____	L3 _____
#11	L1 _____	L2 _____	L3 _____
#12	L1 _____	L2 _____	L3 _____
#13	L1 _____	L2 _____	L3 _____
#14	L1 _____	L2 _____	L3 _____
#15	L1 _____	L2 _____	L3 _____
#16	L1 _____	L2 _____	L3 _____

Vertiv™ Liebert® EconoPhase Pumped Refrigerant Economizer:

- Clean coil and free of debris.
- Check/retorque wire connections.
- Check contactors for pitting. Replace if pitted.
- Check surge protection device status indicator lights (if equipped).
- Verify pump speed control operation.
- Check pump mounting.

Check all that apply:

- Clean coil and free of debris.
- Check mounts are tight.
- Check support/clamps are secure.
- Check/re-torque wire connections.
- Check contactors for pitting. Replace if pitted.
- Check surge protection device status indicator lights (if equipped).
- Check ambient thermostat settings: _____
- Check refrigerant level (Vertiv™ Liebert® Lee-Temp)
- Check refrigerant lines for signs of leaks. Repair as found.
- Check the motor amp draw.

Appendices

Appendix A: Technical Support and Contacts

A.1 Technical Support/Service in the United States

Vertiv Group Corporation

24x7 dispatch of technicians for all products.

1-800-543-2378

Liebert® Thermal Management Products

1-800-543-2778

Liebert® Channel Products

1-800-222-5877

Liebert® AC and DC Power Products

1-800-543-2378

A.2 Locations

United States

Vertiv Headquarters

1050 Dearborn Drive

Columbus, OH, 43085, USA

Europe

Via Leonardo Da Vinci 8 Zona Industriale Tognana

35028 Piove Di Sacco (PD) Italy

Asia

7/F, Dah Sing Financial Centre

3108 Gloucester Road

Wanchai, Hong Kong

This page intentionally left blank

Appendix B: Submittal Drawings

Table B.1 Submittal Drawings Contents

Document Number	Title
Heat Rejection Skid Component Location Drawings	
DPN003888	Component Location Diagram, MCV330 + EconoPhase + Base Assembly
DPN003872	Component Location Diagram MCV330 (2) + EconoPhase (2) + Base Assembly
DPN004258	Component Location Diagram MCV440 + EconoPhase + Base Assembly
DPN004260	Component Location Diagram MCV440 (2) + EconoPhase + Base Assembly
Dimension Planning Drawings	
DPN003889	Cabinet and Anchor Dimensional Data MCV330 + EconoPhase + Base Assembly
DPN003875	Cabinet and Anchor Dimensional Data MCV330 (2) + EconoPhase (2) + Base Assembly
DPN004259	Cabinet and Anchor Dimensional Data MCV440 + EconoPhase + Base Assembly
DPN004261	Cabinet and Anchor Dimensional Data MCV440 (2) + EconoPhase (2) + Base Assembly
Condenser Elevation Above/Below Indoor Unit	
DPN003965	Air Cooled Piping Schematic Liebert® MCV Mounted Above Liebert® DA125-D250
DPN005207	Air Cooled Piping Schematic Liebert® MCV Mounted Above Liebert® DA265
DPN005138, page 1	Air Cooled piping schematic Liebert® MCV mounted above Liebert® XDM
DPN005138, page 2	Air Cooled piping schematic Liebert® MCV mounted below Liebert® XDM
Heat Rejection Skid Drawings	
DPN003882	Cabinet Lifting Points MCV330 + EconoPhase + Base Assembly
DPN003883	Cabinet Lifting Points MCV330 (2) + EconoPhase (2) + Base Assembly
DPN004256	Cabinet Lifting Points MCV440 + EconoPhase + Base Assembly
DPN004263	Cabinet Lifting Points MCV440 (2) + EconoPhase (2) + Base Assembly
Piping General Arrangement Drawings	
DPN004476	Piping Schematic DA125, DA150, and DA250 with Liebert® MCV
DPN005206	Piping Schematic DA265 with Liebert® MCV
DPN005067	Piping Schematic Liebert® XDM with Liebert® MCV
Piping Connection Drawings	
DPN003887	Primary Connection Locations MCV330 + EconoPhase + Base Assy. 460V and 575V
DPN004954	Primary Connection Locations MCV330 + EconoPhase + Base Assy. 380V and 415V
DPN004953	Primary Connection Locations MCV330 (2) + EconoPhase + Base Assy. 380V and 415V
DPN003878	Primary Connection Locations MCV330 + EconoPhase (2) + Base Assy. 460V and 575V
DPN004257	Primary Connection Locations MCV440 + EconoPhase + Base Assembly
DPN004262	Primary Connection Locations MCV440 (2) + EconoPhase (2) + Base Assembly

Table B.2 Submittal Drawings Contents (continued)

Document Number	Title
Electrical Field Connection Drawings	
DPN003879	Electrical Panel Layout MCV330
DPN004212	Electrical Panel Layout, MCV440 Condenser Section
DPN003887	Primary Connection Locations MCV330 + EconoPhase + Base Assy. 460V and 575V
DPN003878	Primary Connection Locations MCV330 + EconoPhase + Base Assy. 460V and 575V
DPN004954	Primary Connection Locations MCV330 + EconoPhase + Base Assy. 380V and 415V
DPN004953	Primary Connection Locations MCV330 (2) + EconoPhase (2) + Base Assy. 380V and 415V
DPN004257	Primary Connection Locations MCV440 + EconoPhase + Base Assembly
DPN004262	Primary Connection Locations MCV440 (2) + EconoPhase (2) + Base Assembly
CANbus Communication Connection Drawings	
DPN003886	CANbus and Interlock Connections Liebert® DSE with Liebert® MCV + Liebert® EconoPhase + Base Assy.
DPN005140	CANbus and Interlock Connections - Liebert® XDM with Liebert® MCV + Liebert® EconoPhase + Base Assy.

HEAT REJECTION SKID

COMPONENT LOCATION DIAGRAM MCV330 + LIEBERT® ECONOPHASE + BASE ASSEMBLY

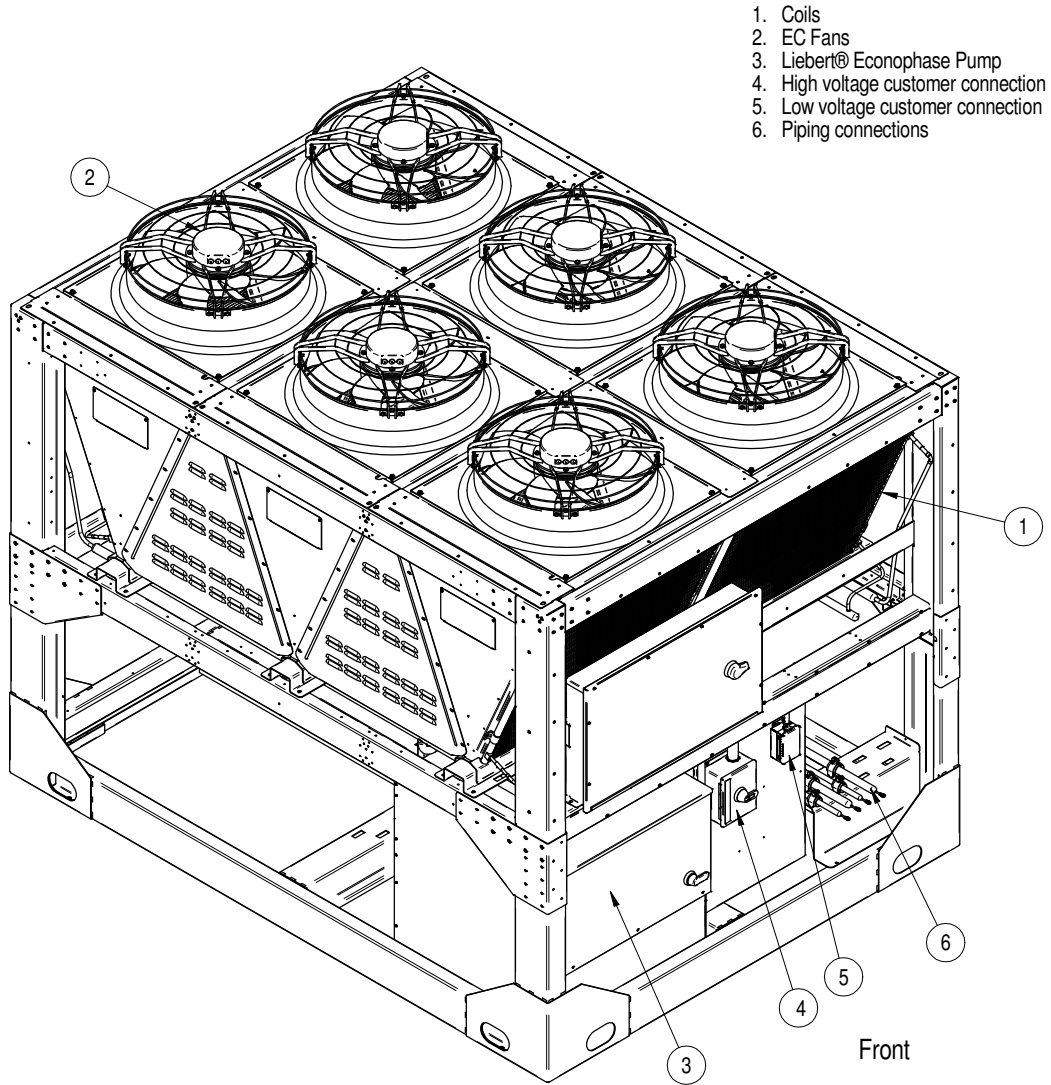

1. Coils
2. EC Fans
3. Liebert® Econophase Pump
4. High voltage customer connection
5. Low voltage customer connection
6. Piping connections

Note:

1. Piping connections for entire assembly are in one location (item 6).
2. Electrical connections for entire assembly are located in high voltage customer connection boxes (item 4) and low voltage customer connection box (item 5).

HEAT REJECTION SKID

COMPONENT LOCATION DIAGRAM

MCV330 (2) + LIEBERT® ECONOPHASE (2) + BASE ASSEMBLY

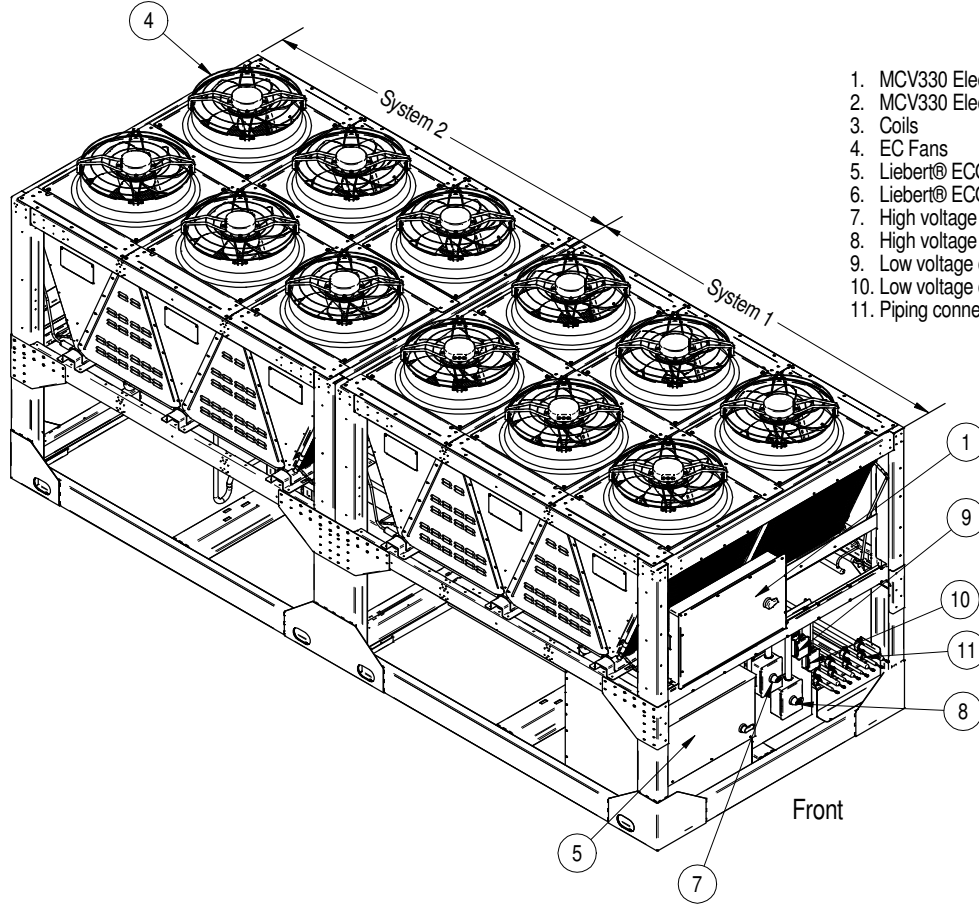

1. MCV330 Electric Panel System 1
2. MCV330 Electric Panel System 2
3. Coils
4. EC Fans
5. Liebert® ECONOPHASE- System 1
6. Liebert® ECONOPHASE- System 2
7. High voltage customer connection System 1
8. High voltage customer connection System 2
9. Low voltage customer connection System 1
10. Low voltage customer connection System 2
11. Piping connections Systems 1&2

Note:

1. Electrical connections for entire assembly are located in high voltage customer connection boxes (items 7 & 8) and low voltage customer connection box (item 9 & 10).
2. Piping connections for entire assembly are in one location (item 11).

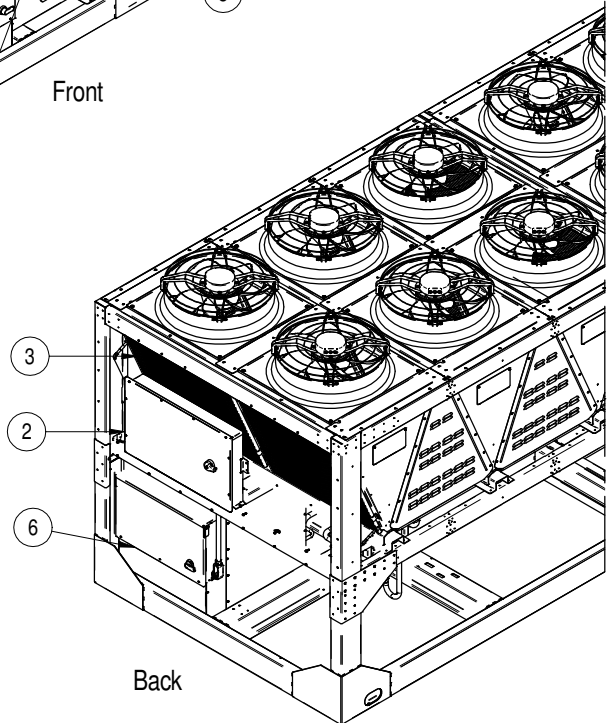

HEAT REJECTION SKID

COMPONENT LOCATION DIAGRAM MCV440 + LIEBERT® ECONOPHASE + BASE ASSEMBLY

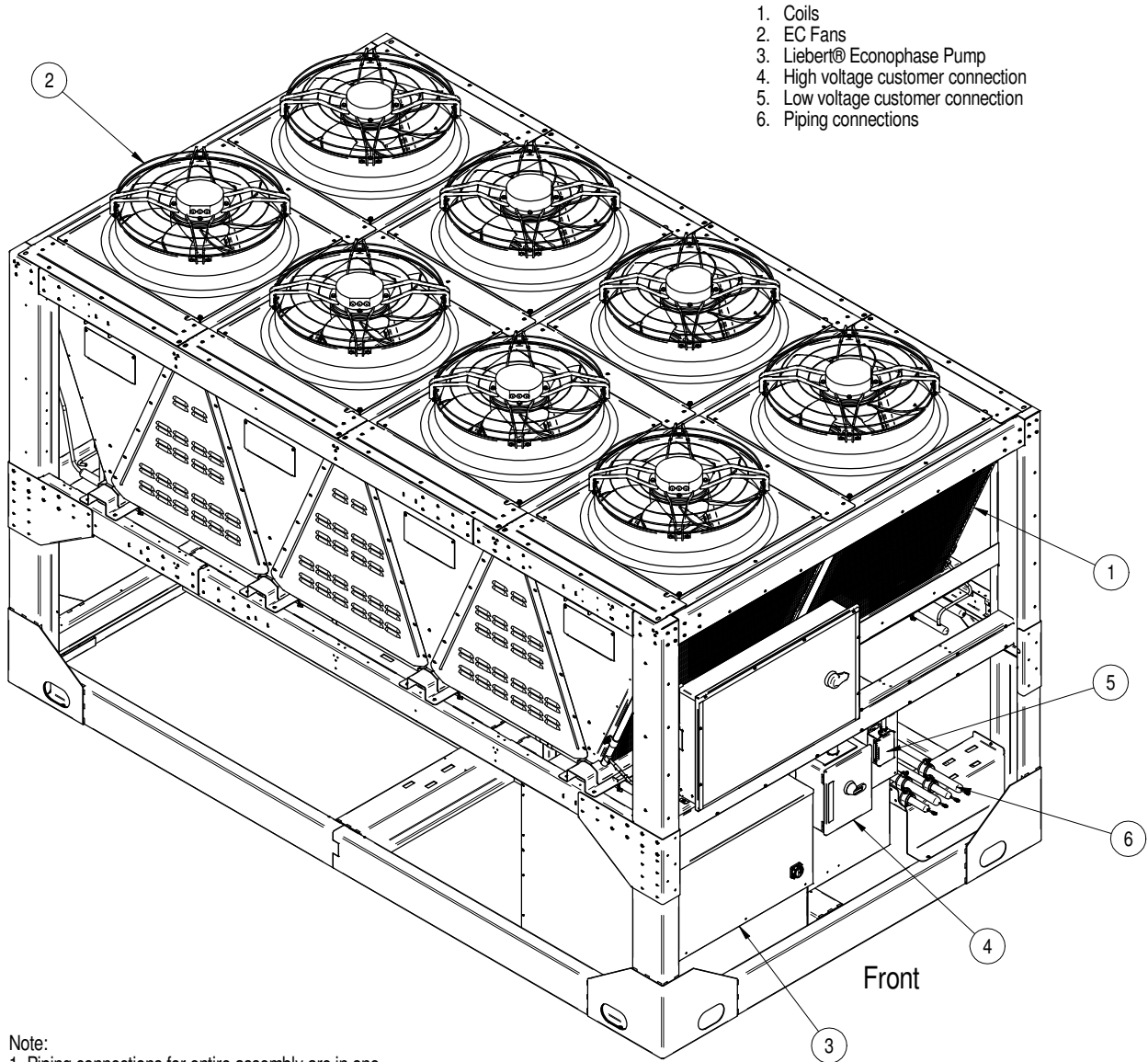

1. Coils
2. EC Fans
3. Liebert® Econophase Pump
4. High voltage customer connection
5. Low voltage customer connection
6. Piping connections

Note:

1. Piping connections for entire assembly are in one location (item 6).
2. Electrical connections for entire assembly are located in high voltage customer connection boxes (item 4) and low voltage customer connection box (item 5).

HEAT REJECTION SKID

COMPONENT LOCATION DIAGRAM

MCV440 (2) + LIEBERT® ECONOPHASE (2) + BASE ASSEMBLY

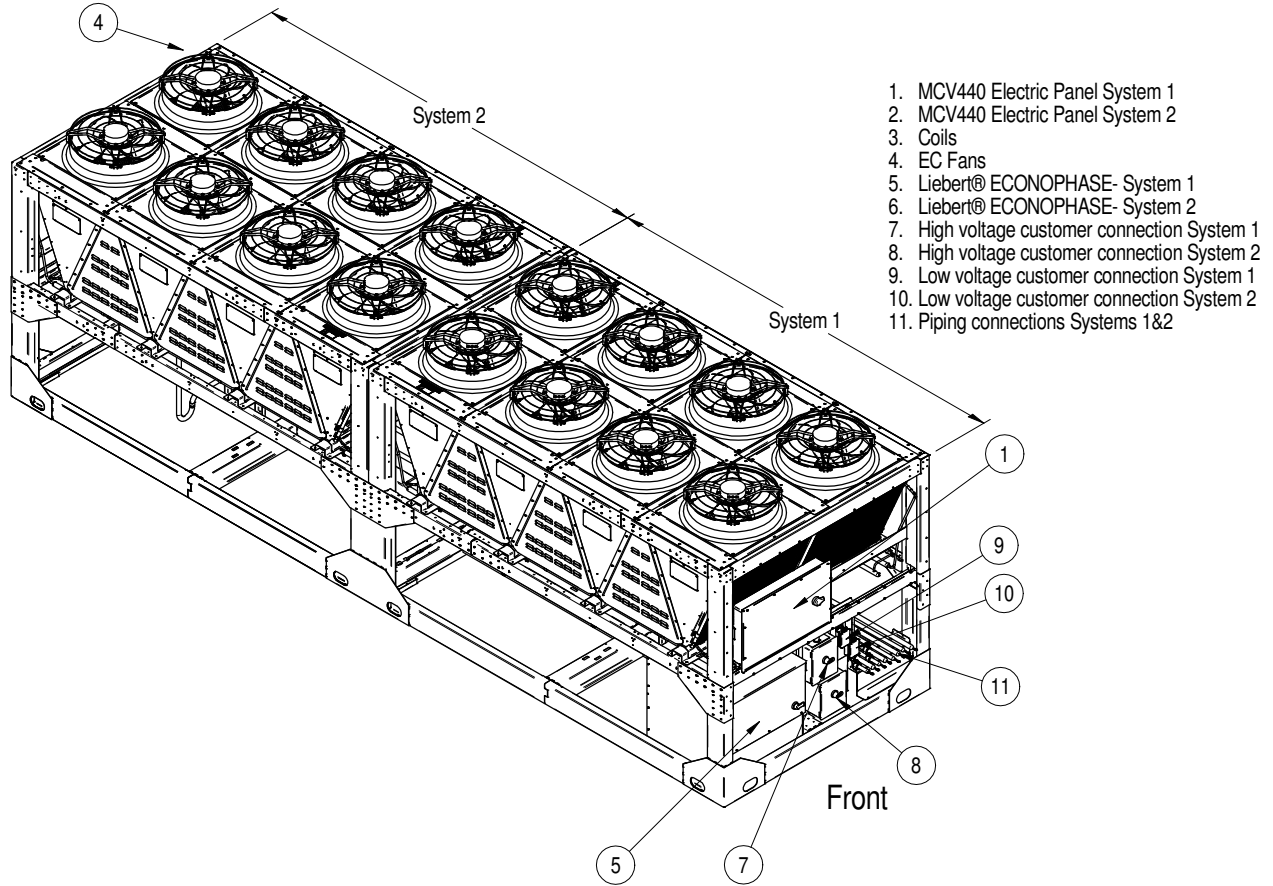

Note:

1. Electrical connections for entire assembly are located in high voltage customer connection boxes (items 7 & 8) and low voltage customer connection box (item 9 & 10).
2. Piping connections for entire assembly are in one location (item 11).

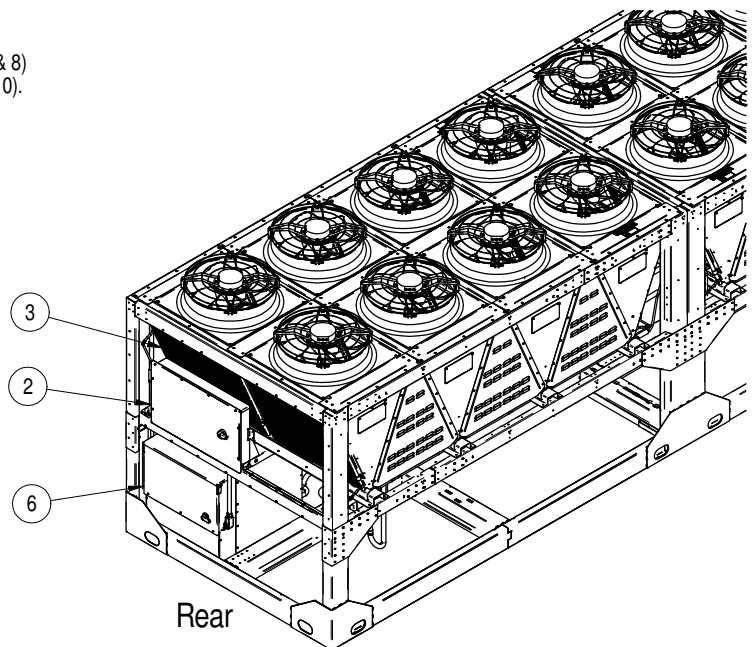



LIEBERT® HEAT REJECTION SKID

CABINET & ANCHOR DIMENSIONAL DATA

LIEBERT® MCV MCV330 + LIEBERT® ECONOPHASE + BASE ASSEMBLY

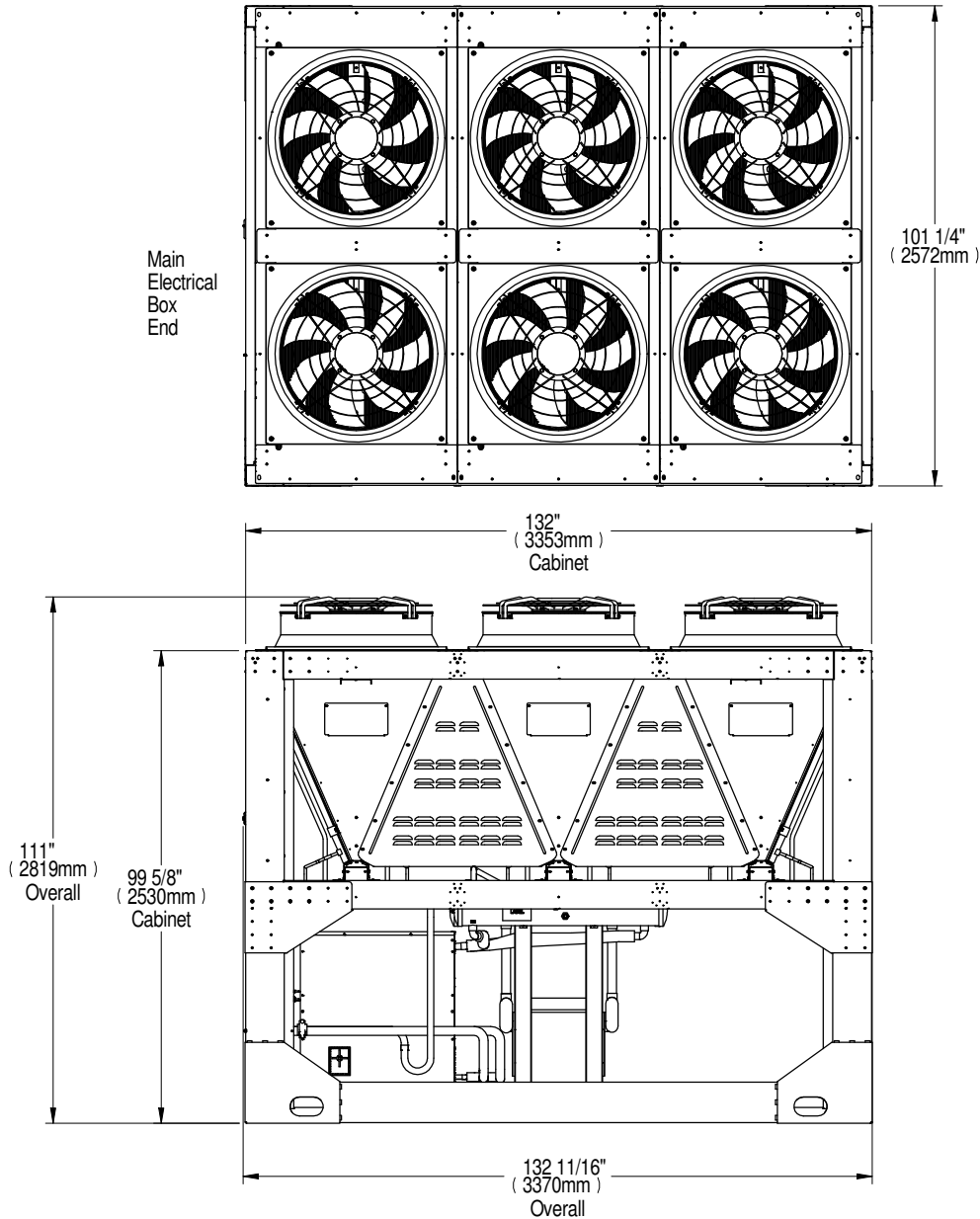

Model	Domestic Shipping Weight lb (kg)	Export Shipping Weight lb (kg)
MCV330 Single Skid with Receiver	5000 (2268)	5200 (2359)
MCV330 Single Skid without Receiver	4900 (2223)	5100 (2313)

NOTES:

- 1) Minimum clearance on the Main Unit Disconnect Enclosure shall be 48" (1219mm) or per local code.
- 2) Recommended minimum 48" (1219mm) clearance when multiple skids are mounted side by side to ensure proper airflow. Contact the factory for other spacing requirements.



LIEBERT® HEAT REJECTION SKID

CABINET & ANCHOR DIMENSIONAL DATA

LIEBERT® MCV MCV330 + LIEBERT® ECONOPHASE + BASE ASSEMBLY

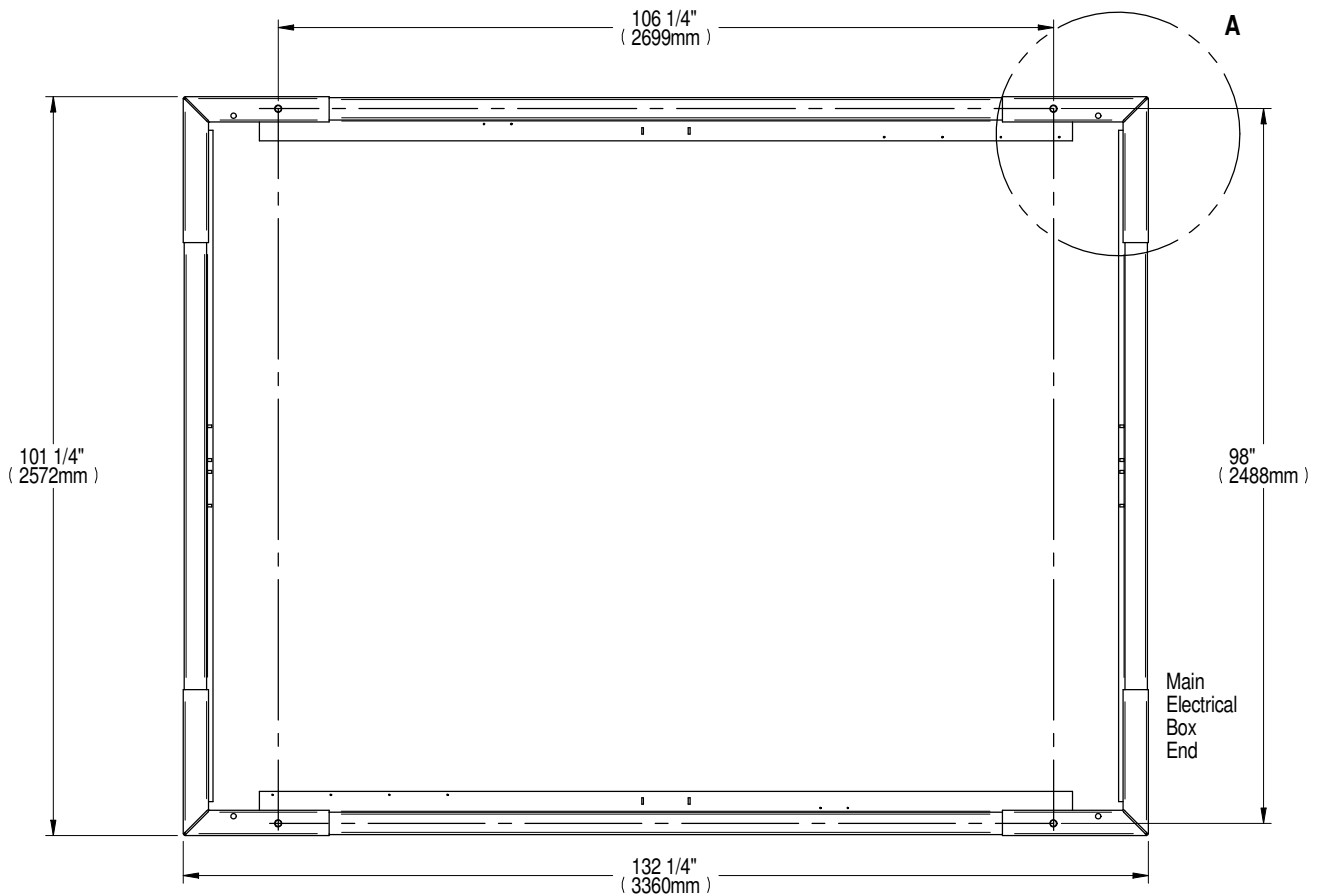
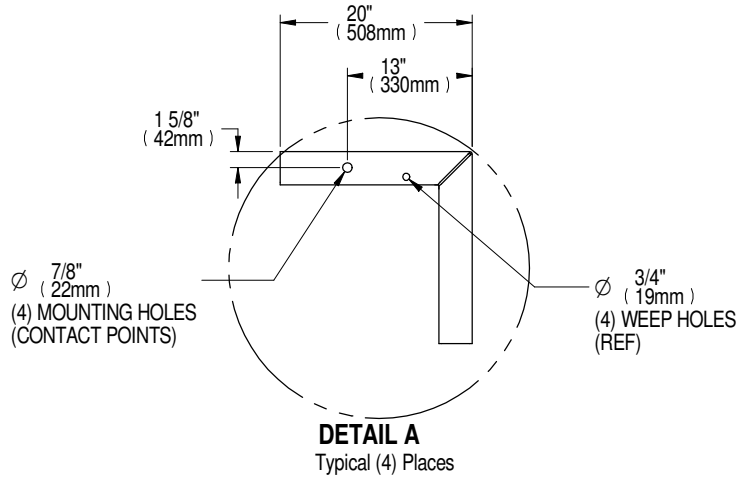

NOTES:

- 1) Underside of unit, coil and fan removed for clarity.
- 2) Four mounting holes and four 3/4" field supplied bolts required to secure skid base assembly to customer support structure. Bolt grade to be specified by local requirements.



LIEBERT® HEAT REJECTION SKID

CABINET & ANCHOR DIMENSIONAL DATA LIEBERT® MCV MCV330 (2) + LIEBERT® ECONOPHASE(2) + BASE ASSEMBLY

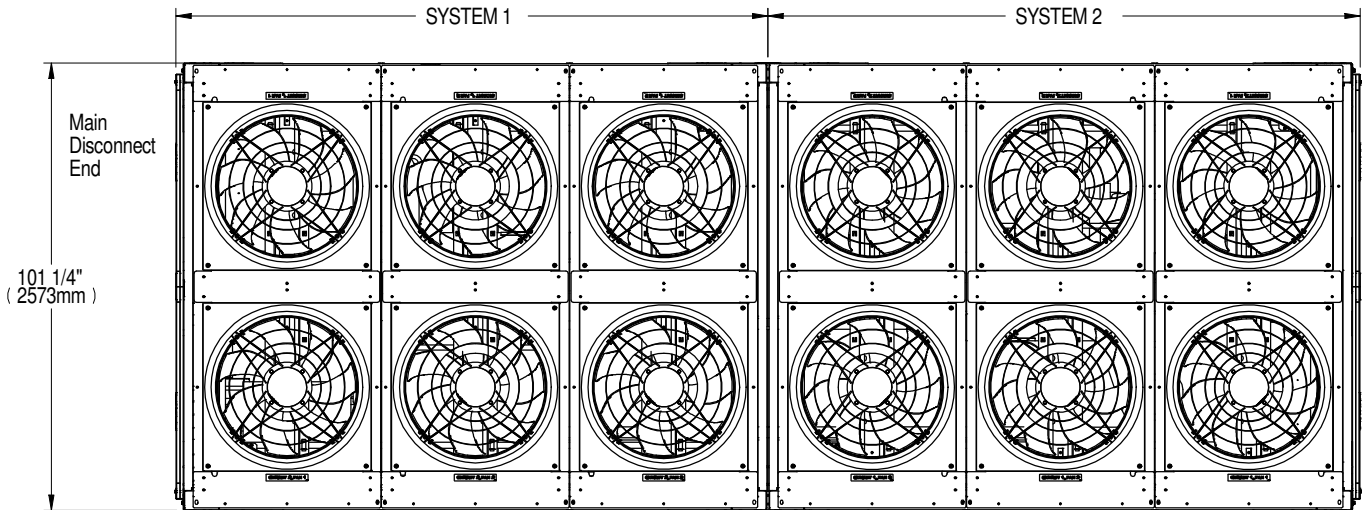

Top View

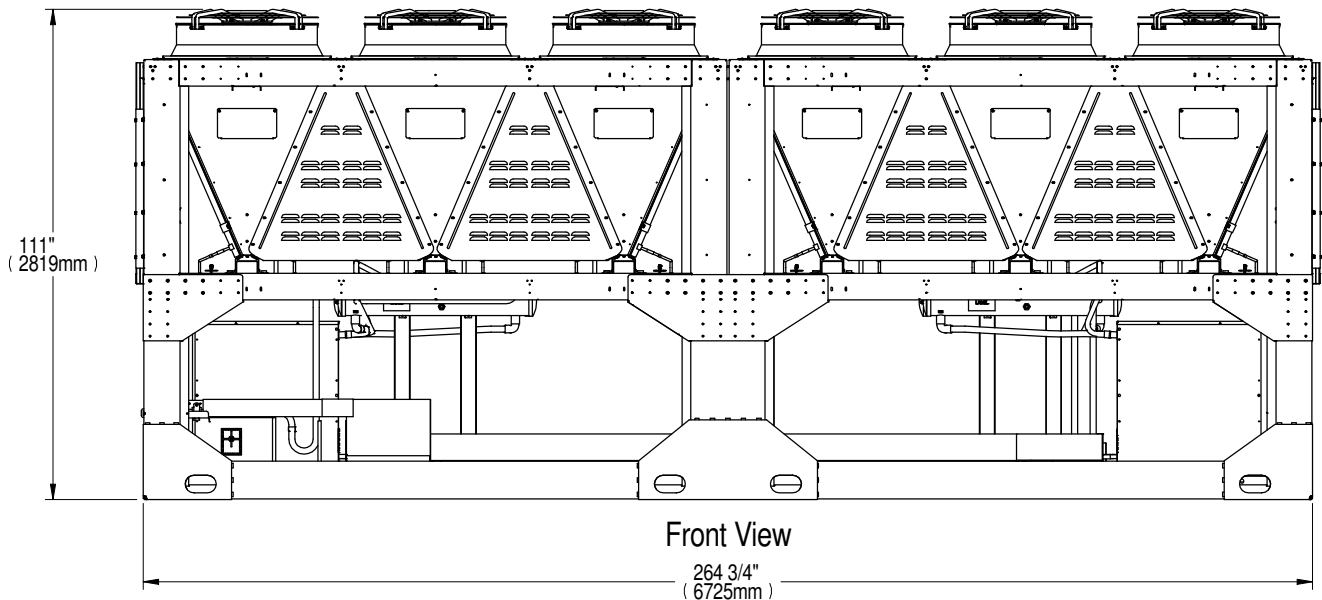

Front View

Model	Domestic Shipping Weight lb (kg)	Export Shipping Weight lb (kg)
MCV330 Dual Skid with Receiver	10,000 (4535)	10,350 (4695)
MCV330 Dual Skid without Receiver	9800 (4445)	10,150 (4604)

- Notes:
1. Minimum clearance of the Main Unit Disconnect Enclosure shall be 48" (1219mm) or per local electrical code.
 2. Recommended minimum 48" (1219mm) clearance when multiple skids are mounted side by side to ensure proper airflow. Contact the factory for other spacing requirements.



LIEBERT® HEAT REJECTION SKID

CABINET & ANCHOR DIMENSIONAL DATA LIEBERT® MCV MCV330 (2) + LIEBERT® ECONOPHASE(2) + BASE ASSEMBLY

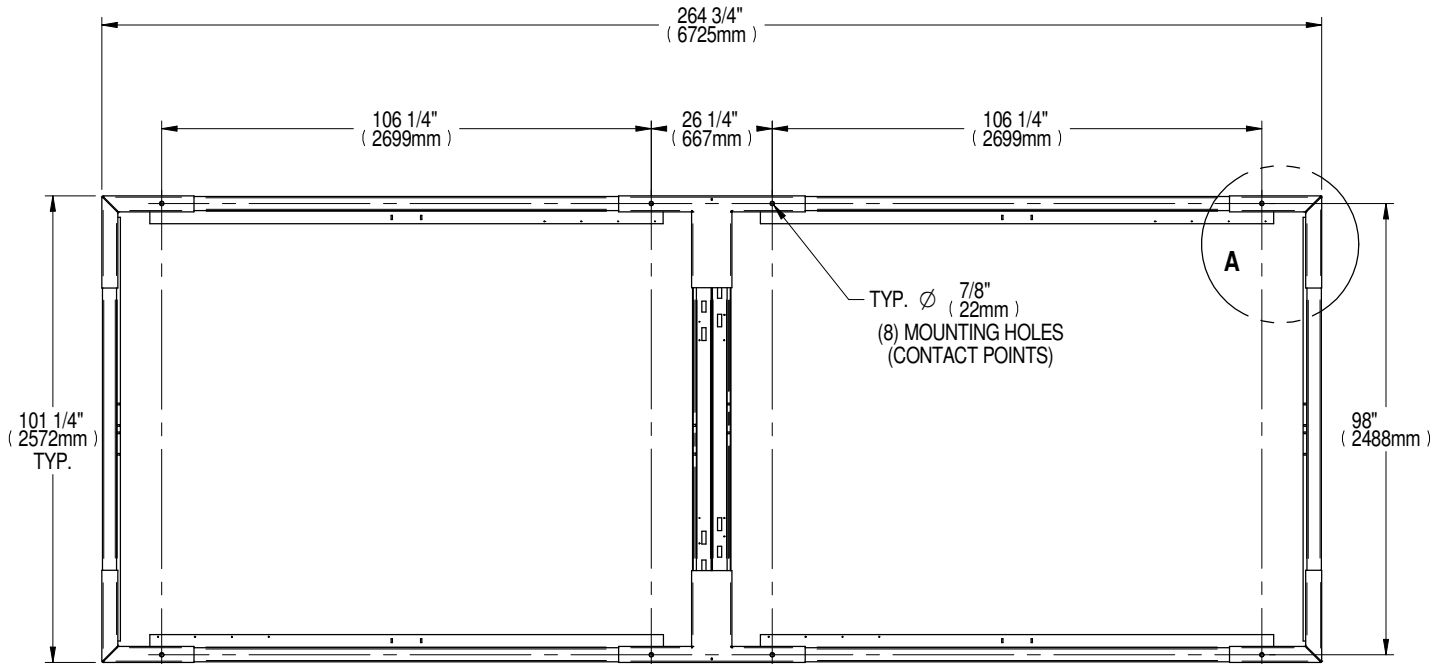

Underside of unit, coil and fan removed for clarity.

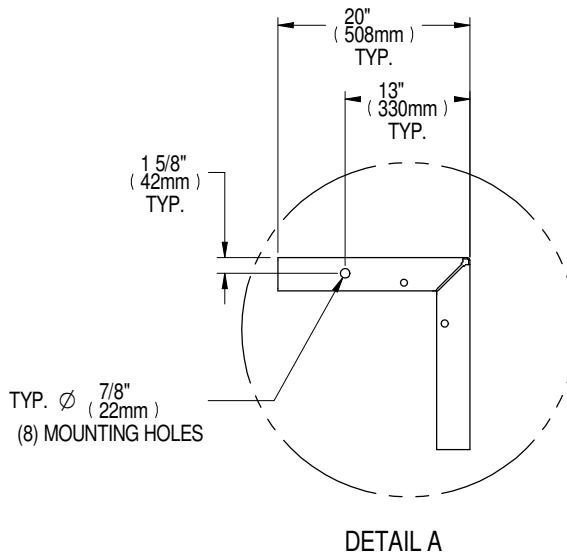

Notes:

1. Eight mounting holes and eight 3/4" field supplied bolts required to secure skid base assembly to customer support structure. Bolt grade to be specified by local requirements.



LIEBERT® HEAT REJECTION SKID

CABINET & ANCHOR DIMENSIONAL DATA

LIEBERT® MCV MCV440 + LIEBERT® ECONOPHASE + BASE ASSEMBLY

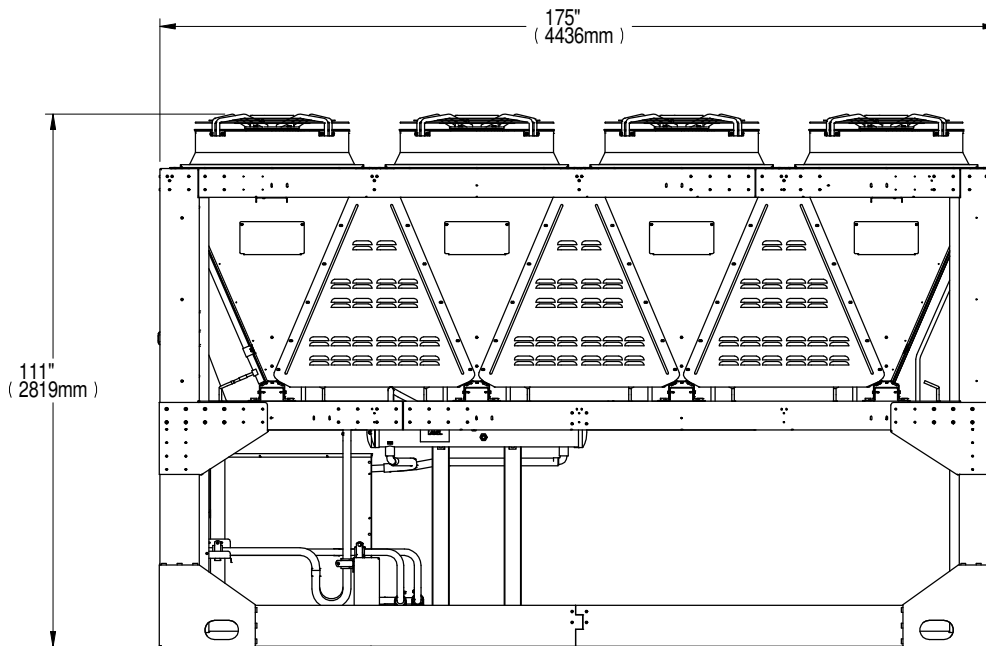
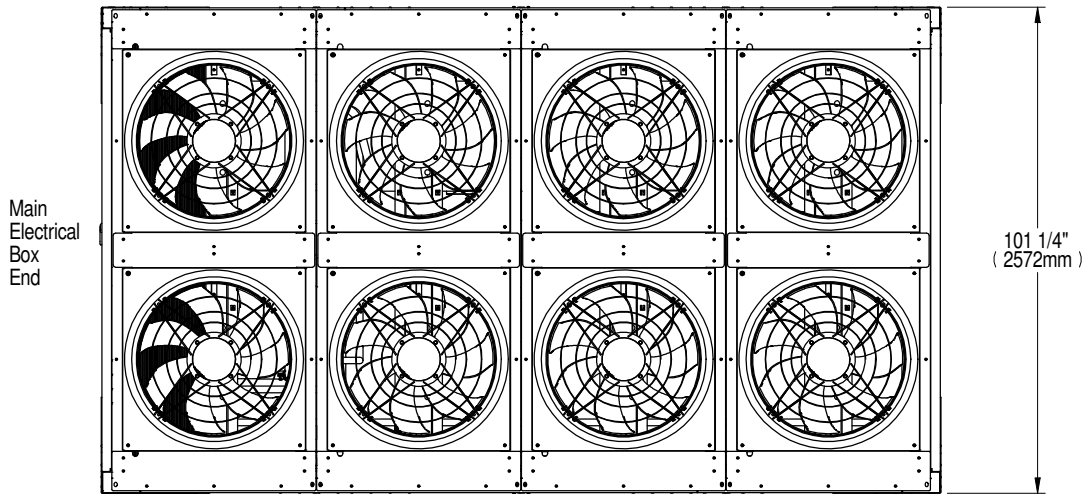

Model	Domestic Shipping Weight lb. (kg)	Export Shipping Weight lb. (kg)
MCV440 Single Skid with Receiver	5900 (2676)	6140 (2785)
MCV440 Single Skid without Receiver	5800 (2630)	6040 (2740)

NOTES:

- 1) Minimum clearance on the Main Unit Disconnect Enclosure shall be 48" (1219mm) or per local code.
- 2) Recommended minimum 48" (1219mm) clearance when multiple skids are mounted side by side to ensure proper airflow. Contact the factory for other spacing requirements.



LIEBERT® HEAT REJECTION SKID

CABINET & ANCHOR DIMENSIONAL DATA

LIEBERT® MCV MCV440 + LIEBERT® ECONOPHASE + BASE ASSEMBLY

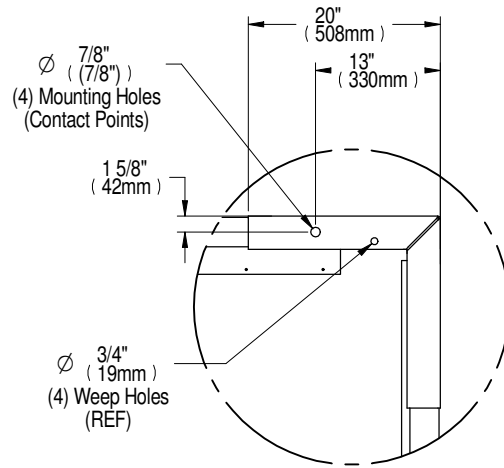

DETAIL A
Typ. (4) Places

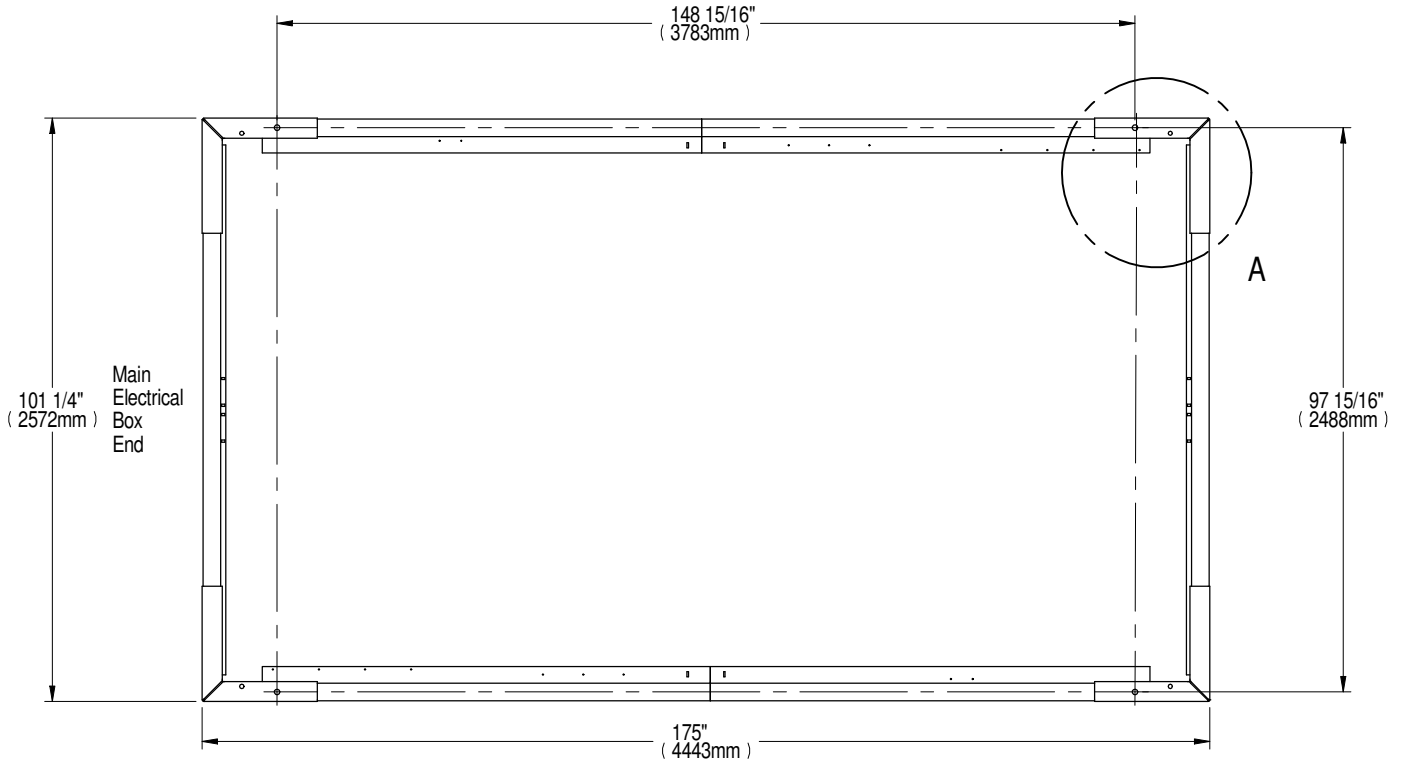

NOTES:

- 1) Underside of unit, coil and fan removed for clarity.
- 2) Four mounting holes and four 3/4" field supplied bolts required to secure skid base assembly to customer support structure. Bolt grade to be specified by local requirements.



LIEBERT® HEAT REJECTION SKID

CABINET & ANCHOR DIMENSIONAL DATA LIEBERT® MCV MCV440 (2) + LIEBERT® ECONOPHASE (2) + BASE ASSEMBLY

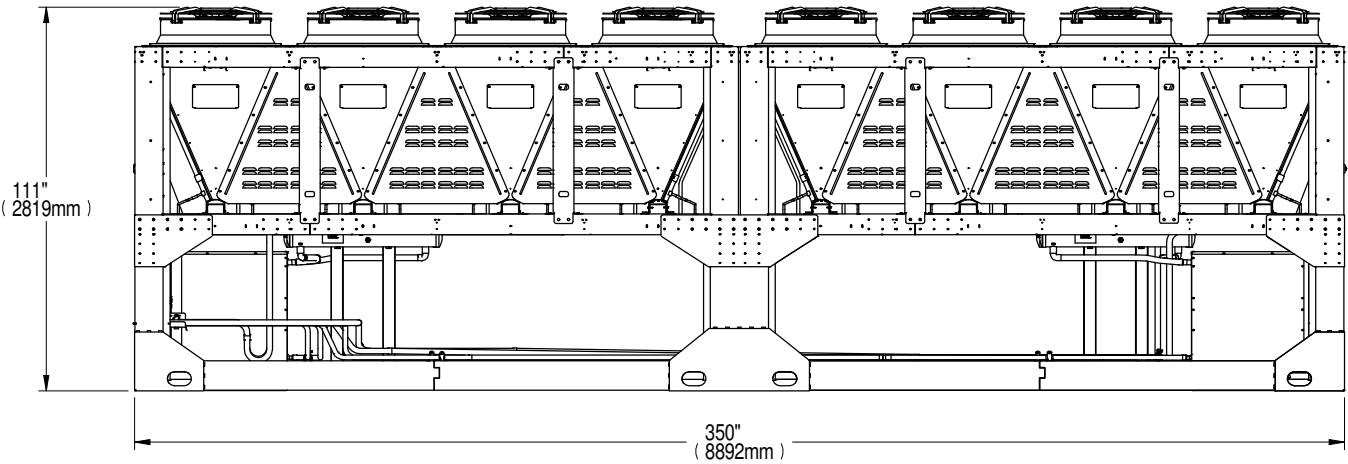
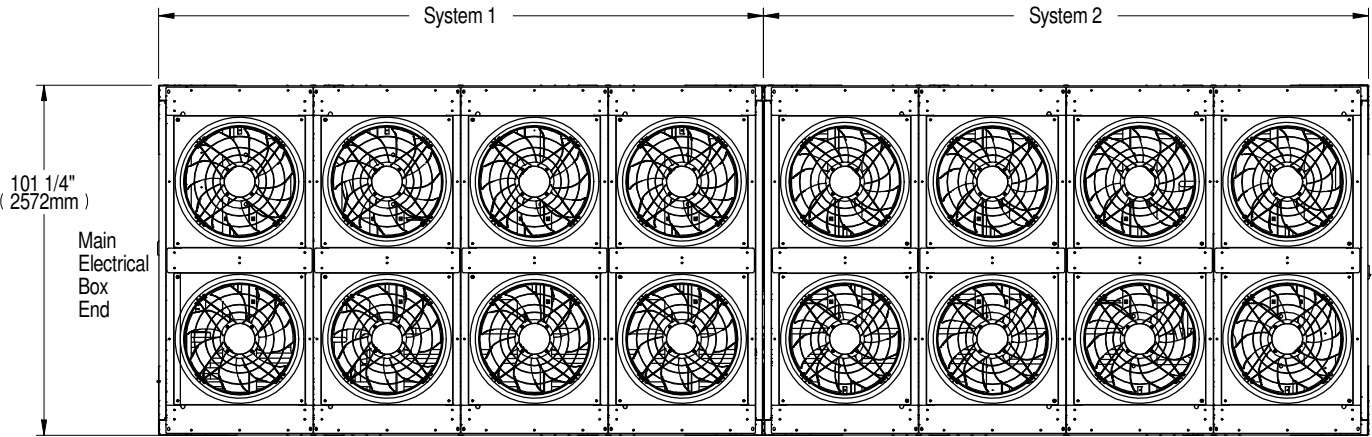

Model	Domestic Shipping Weight lb (kg)	Export Shipping Weight lb (kg)
MCV440 Dual Skid with Receiver	11,580 (5252)	11,960 (5425)
MCV440 Dual Skid without Receiver	11,380 (5162)	11,760 (5434)

Notes:

1. Minimum clearance of the Main Unit Disconnect Enclosure shall be 48" (1219mm) or per local electrical code.
2. Recommended minimum 48" (1219mm) clearance when multiple skids are mounted side by side to ensure proper airflow. Contact the factory for other spacing requirements.



LIEBERT® HEAT REJECTION SKID

CABINET & ANCHOR DIMENSIONAL DATA LIEBERT® MCV MCV440 (2) + LIEBERT® ECONOPHASE (2) + BASE ASSEMBLY

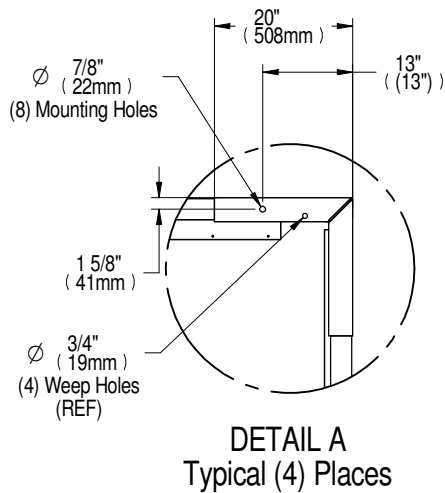
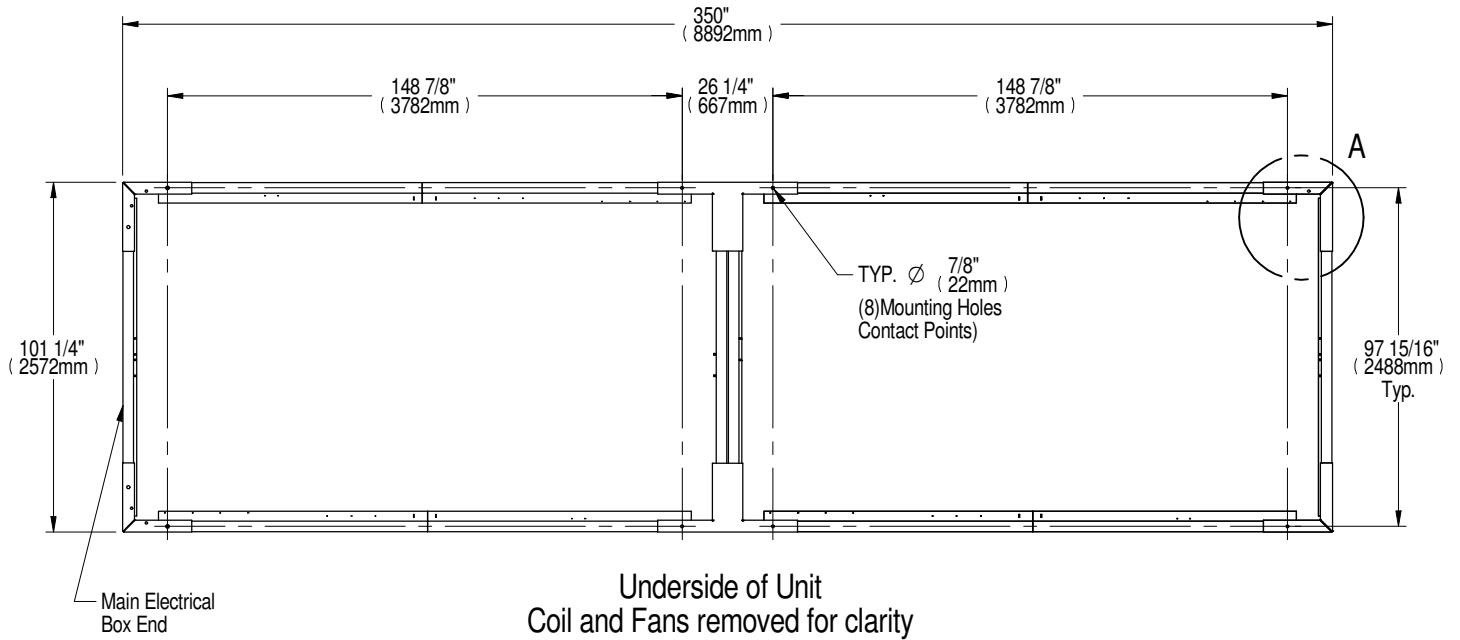

Notes:

1. Eight mounting holes and eight 3/4" field supplied bolts required to secure skid base assembly to customer support structure. Bolt grade to be specified by local requirements.

AIR COOLED PIPING SCHEMATIC LIEBERT® MCV WITH RECEIVERS MOUNTED ABOVE DA125-250

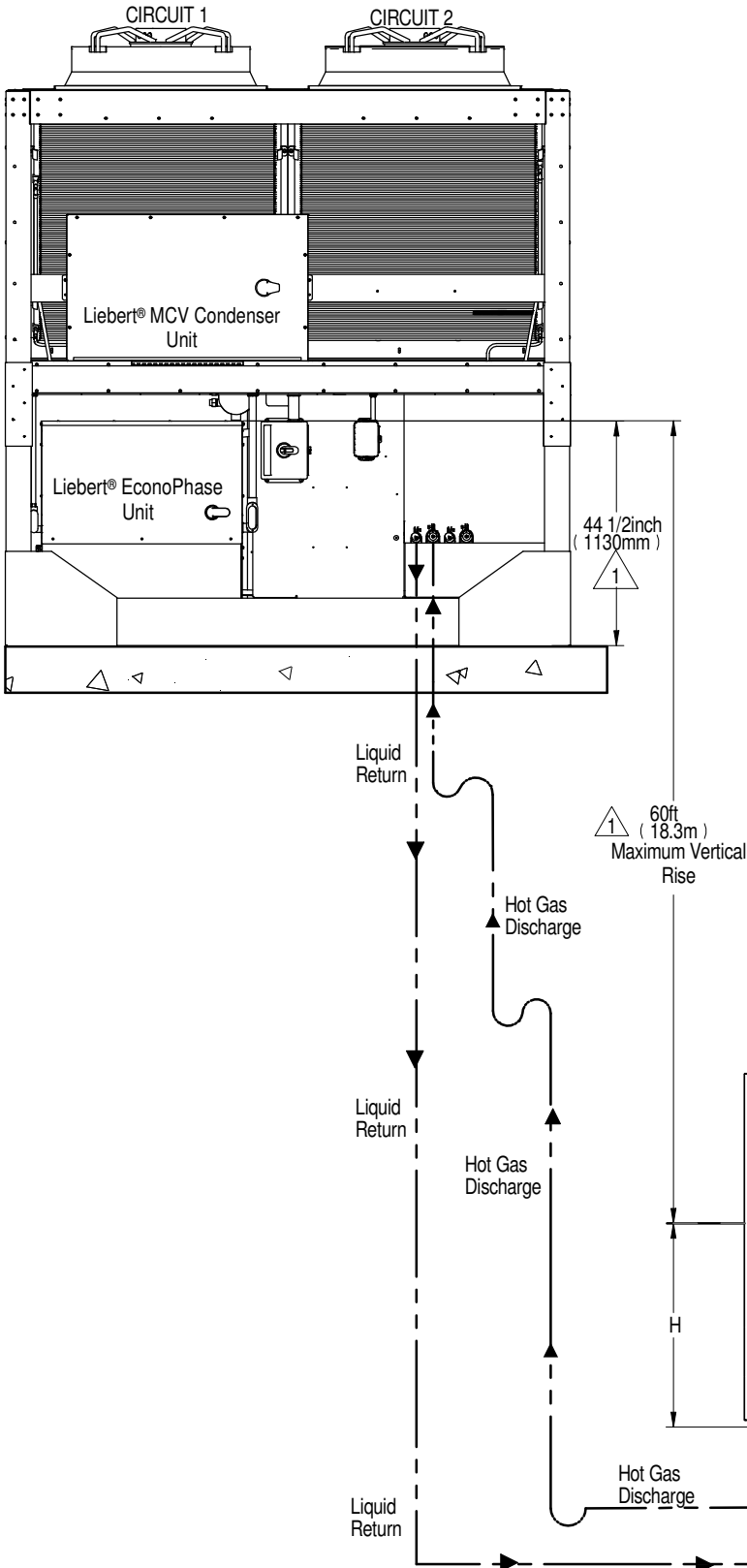

Notes:

1. The outlet of the receiver must be higher than the elevation of the EEV inside the indoor unit. The vertical height must not be greater than 60 ft (18.3 m).
2. Unit must be trapped at bottom of riser with any rise over 5 feet (1.5m) high. If rise exceeds 25 feet (7.5m), then a trap is required in 20 foot (6.1m) increments or evenly divided. DA250 with horizontal discharge has internally installed traps on the hot gas discharge line.
3. Pitch horizontal hot gas piping at a minimum of 1/2 inch per 10 feet (42mm per 10m) so that gravity will aid in moving oil in the direction of the refrigeration flow.
4. Unit piping entrance varies by unit and may be through the top of the unit.
5. All indoor field refrigerant piping must be insulated, 1/2" minimum thickness. All outdoor field refrigerant piping does not need to be insulated. The installing contractor is responsible for the insulating, securing, protecting and the proper installation of all field refrigerant piping, observing the details outlined by the Engineer of Record.
6. Consult factory for any exceptions to the above guidelines.

Internal EEV Height	H inch (mm)
DA125-DA165	43 (1092)
DA250	56 (1422)

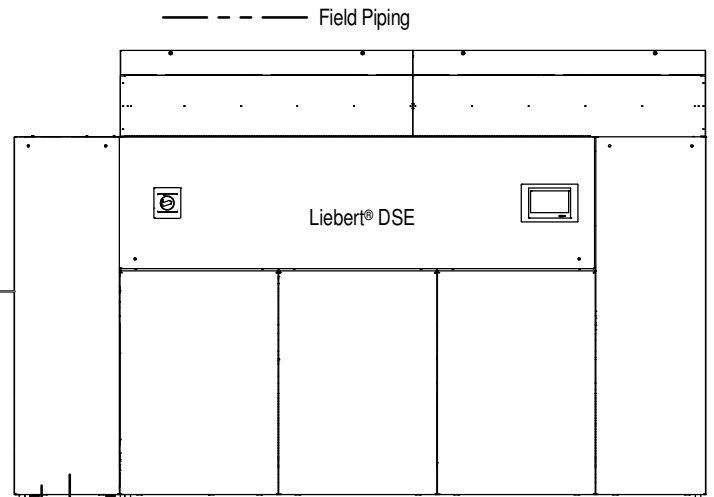

Notes:

DA250 with horizontal discharge should be piped out the top of the unit.

AIR COOLED PIPING SCHEMATIC DA125-250 AND LIEBERT® MCV WITH RECEIVERS AT SIMILAR LEVELS

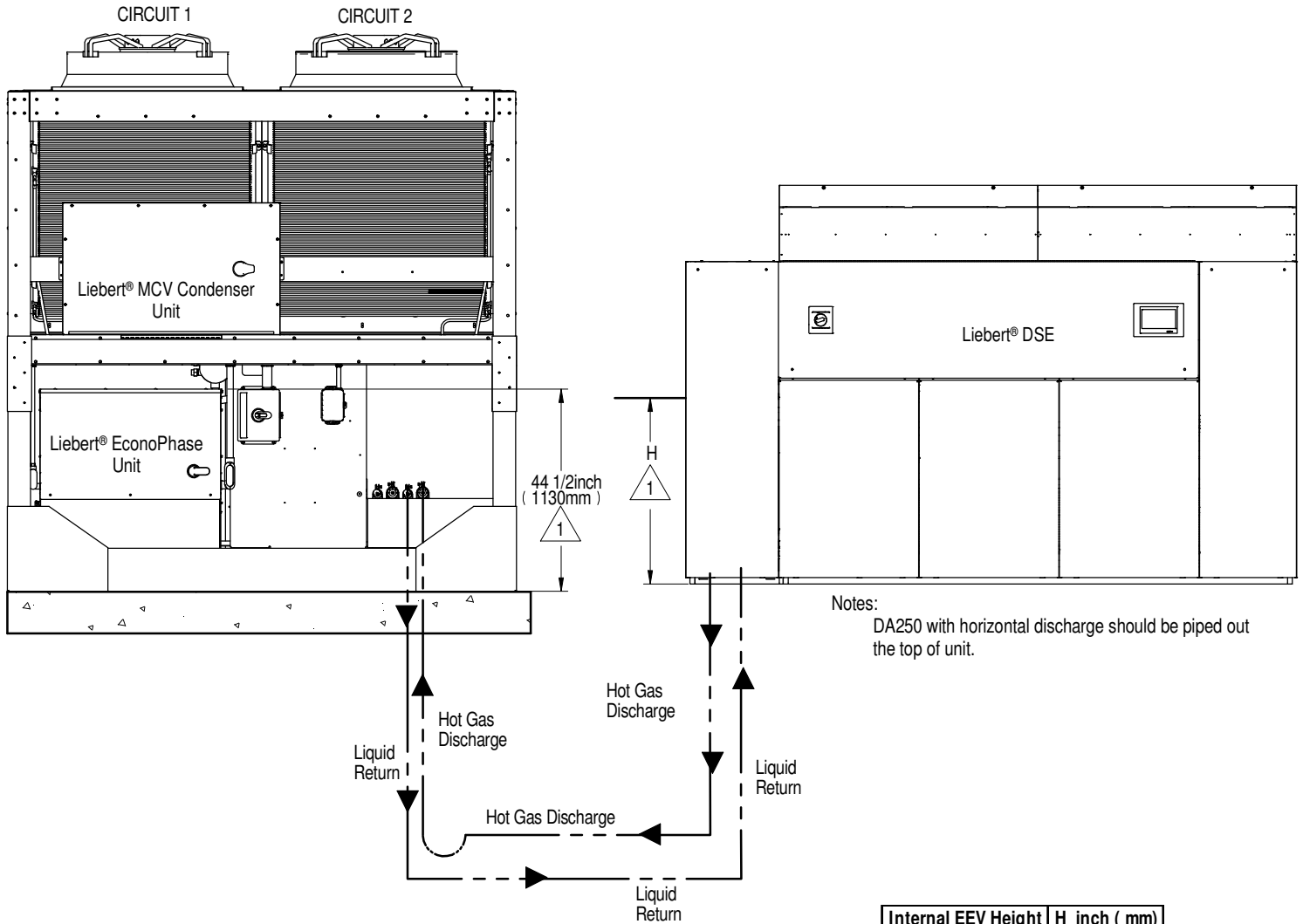

Notes:

1. The outlet of the receiver must be higher than the elevation of the EEV inside the indoor unit.
2. Unit must be trapped at bottom of riser with any rise over 5 feet (1.5m) high. If rise exceeds 25 feet (7.5m), then a trap is required in 20 foot (6.1m) increments or evenly divided. DA250 with horizontal discharge has internally installed traps on the hot gas discharge line.
3. Pitch horizontal hot gas piping at a minimum of 1/2 inch per 10 feet (42mm per 10m) so that gravity will aid in moving oil in the direction of the refrigeration flow.
4. Unit piping entrance varies by unit and may be through the top of the unit.
5. All indoor field refrigerant piping must be insulated, 1/2" minimum thickness. All external field refrigeration piping between the indoor and Liebert® Heat Rejection unit do not need to be insulated. The installing contractor is responsible for the insulating, securing, protecting and the proper installation of all field refrigerant piping, observing the details outlined by the Engineer of Record.
6. Consult factory for any exceptions to the above guidelines.

----- Field Piping

AIR COOLED PIPING SCHEMATIC

Liebert® MCV WITHOUT RECEIVERS MOUNTED ABOVE DA125-265

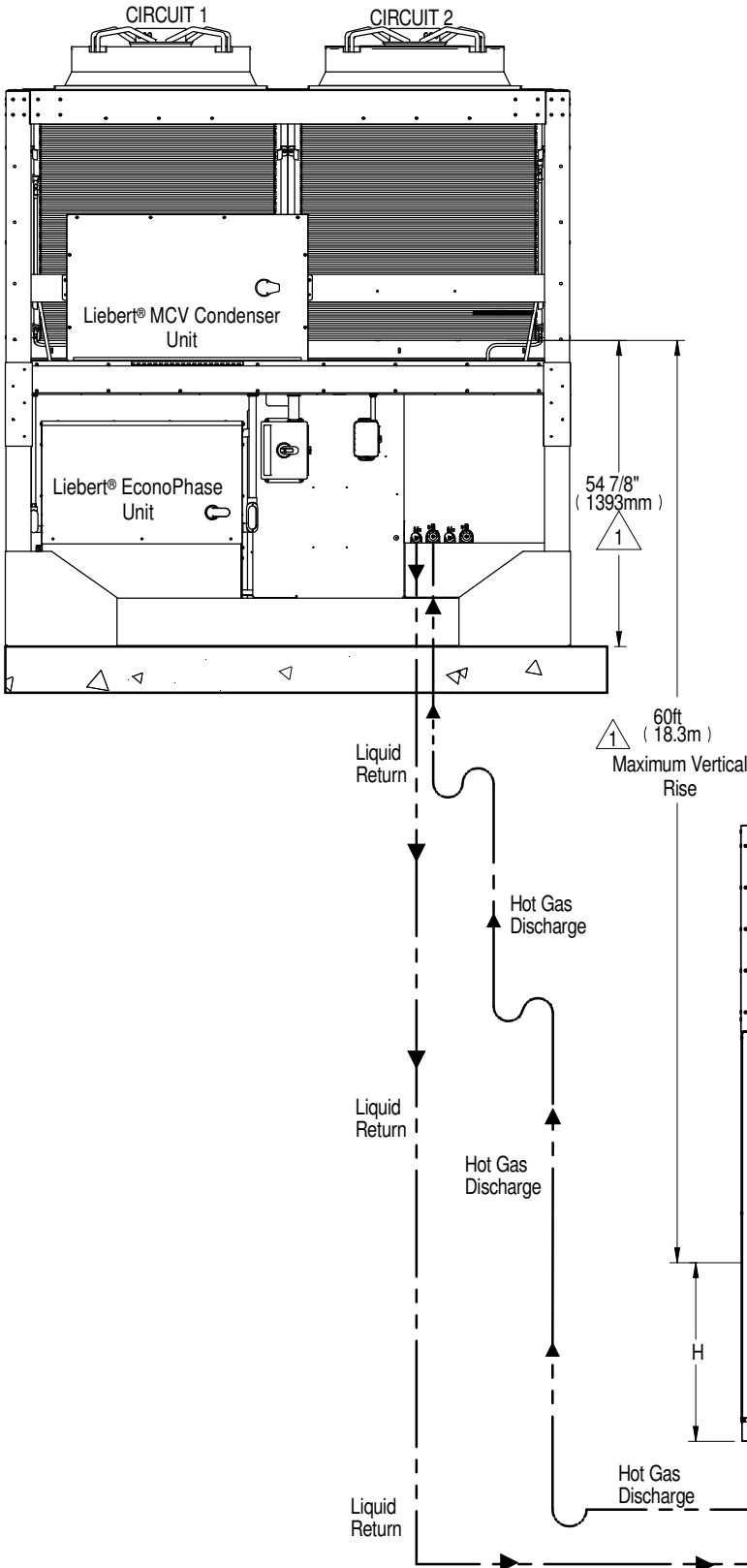

Notes:

1. The bottom of the condenser coil must be no greater than 60 ft (18.3m) higher than the elevation of the EEV inside the indoor unit.
2. Unit must be trapped at bottom of riser with any rise over 5 feet (1.5m) high. If rise exceeds 25 feet (7.5m), then a trap is required in 20 foot (6.1m) increments or evenly divided. DA265 with horizontal discharge has internally installed traps on the hot gas discharge line.
3. Pitch horizontal hot gas piping at a minimum of ½ inch per 10 feet (42mm per 10m) so that gravity will aid in moving oil in the direction of the refrigeration flow.
4. Unit piping entrance varies by unit and may be through the top of the unit.
5. All indoor field refrigerant piping must be insulated, 1/2" minimum thickness. All outdoor field refrigerant piping does not need to be insulated. The installing contractor is responsible for the insulating, securing, protecting and the proper installation of all field refrigerant piping, observing the details outlined by the Engineer of Record.
6. Consult factory for any exceptions to the above guidelines.
7. DA265 with horizontal discharge should be piped out the top of unit.

Internal EEV Height	H inch (mm)
DA125-DA165	43 (1092)
DA250	56 (1422)
DA265	56 (1422)

----- Field Piping

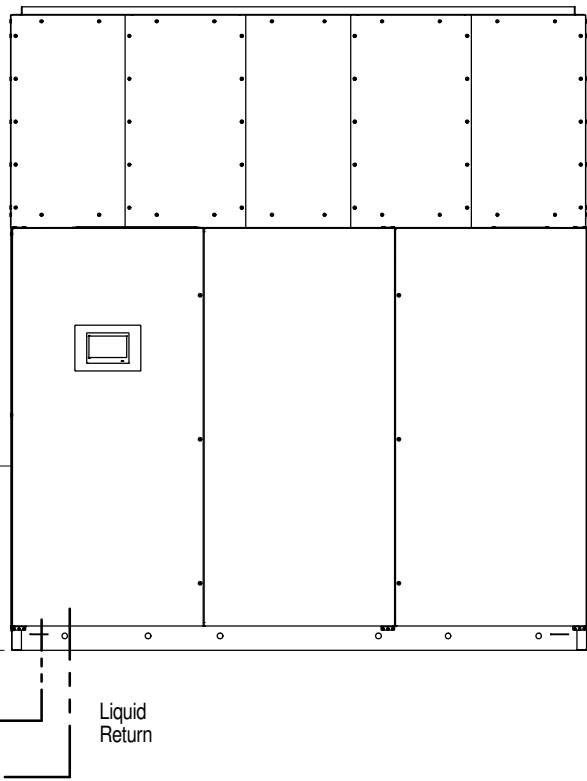

AIR COOLED PIPING SCHEMATIC DA125-265 AND Liebert® MCV WITHOUT RECEIVERS AT SIMILAR OR BELOW LEVELS

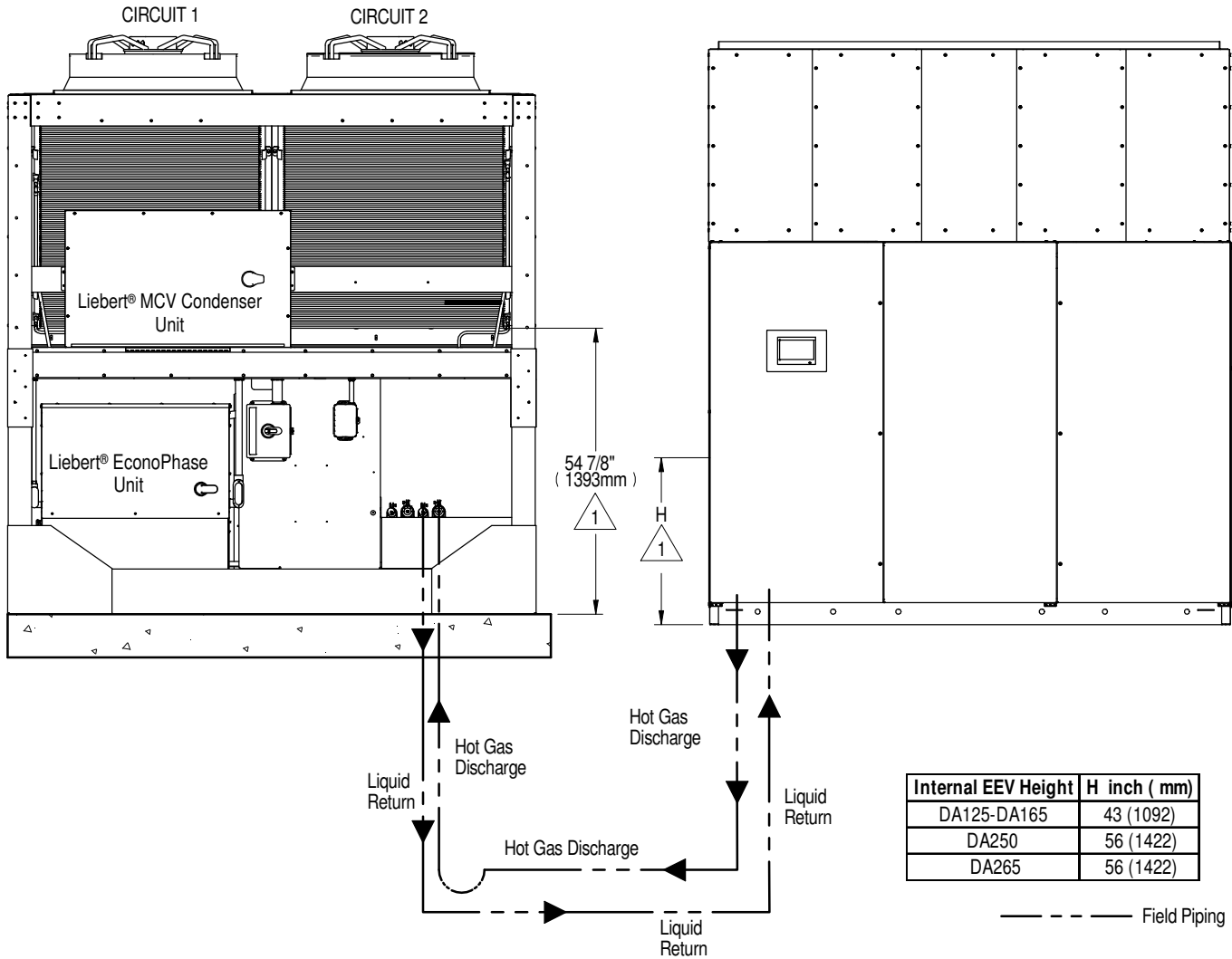

Notes:

1.  The bottom of the condenser coil must be less than 15ft(4.6m) below the elevation of the EEV inside the indoor unit.
2. Unit must be trapped at bottom of riser with any rise over 5 feet (1.5m) high. If rise exceeds 25 feet (7.5m), then a trap is required in 20 foot (6.1m) increments or evenly divided. DA265 with horizontal discharge has internally installed traps on the hot gas discharge line.
3. Pitch horizontal hot gas piping at a minimum of 1/2 inch per 10 feet (42mm per 10m) so that gravity will aid in moving oil in the direction of the refrigeration flow.
4. Unit piping entrance varies by unit and may be through the top of the unit.
5. All indoor field refrigerant piping must be insulated, 1/2" minimum thickness. All outdoor field refrigeration piping does not need to be insulated. The installing contractor is responsible for the insulating, securing, protecting and the proper installation of all field refrigerant piping, observing the details outlined by the Engineer of Record.
6. Consult factory for any exceptions to the above guidelines.
7. DA265 with horizontal discharge should be piped out the top of unit.

AIR COOLED PIPING SCHEMATIC

LIEBERT® MCV WITHOUT RECEIVER MOUNTED ABOVE LIEBERT® XDM

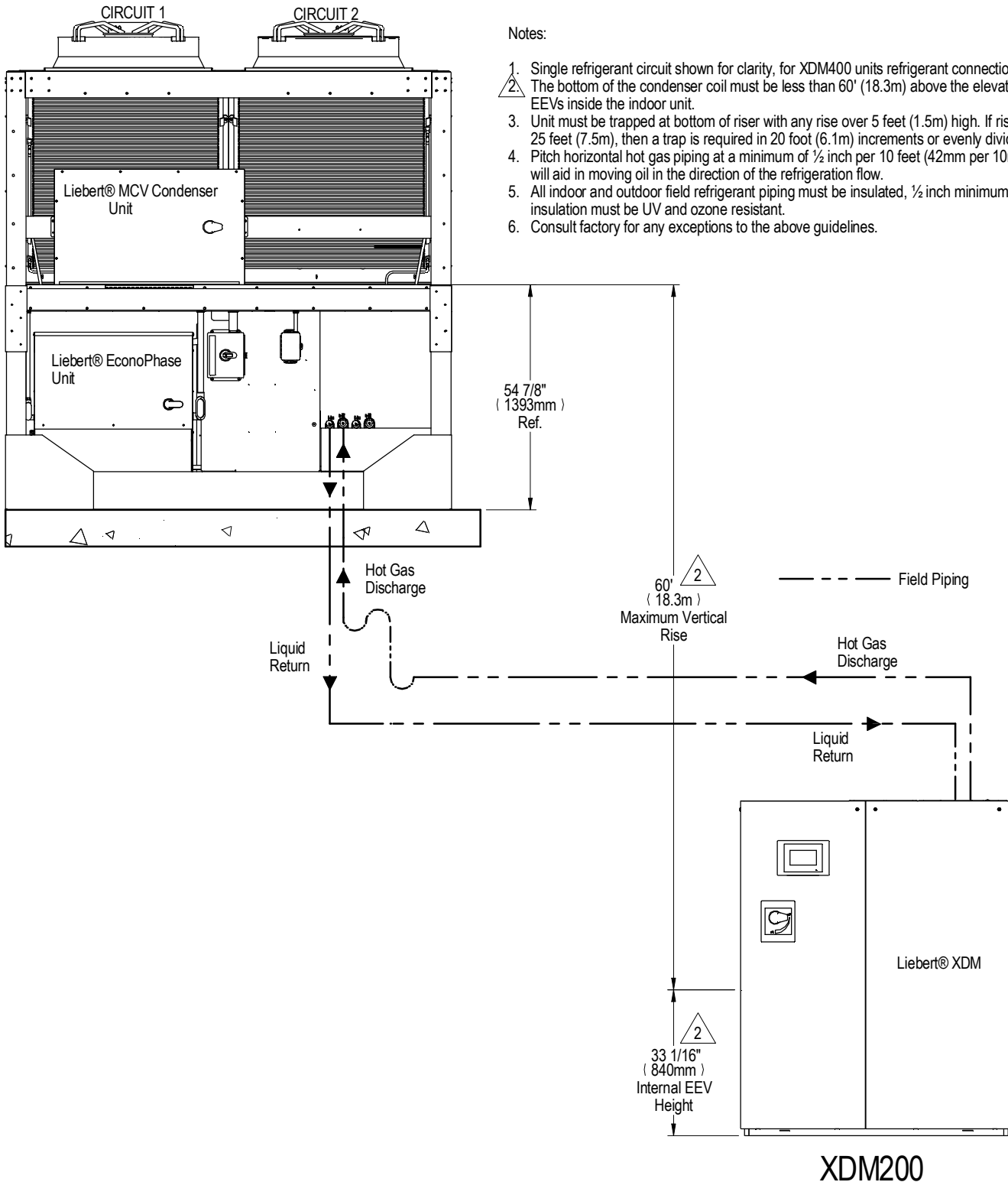

Notes:

1. Single refrigerant circuit shown for clarity, for XDM400 units refrigerant connections are typical.
2. The bottom of the condenser coil must be less than 60' (18.3m) above the elevation of the EEVs inside the indoor unit.
3. Unit must be trapped at bottom of riser with any rise over 5 feet (1.5m) high. If rise exceeds 25 feet (7.5m), then a trap is required in 20 foot (6.1m) increments or evenly divided.
4. Pitch horizontal hot gas piping at a minimum of 1/2 inch per 10 feet (42mm per 10m) so that gravity will aid in moving oil in the direction of the refrigeration flow.
5. All indoor and outdoor field refrigerant piping must be insulated, 1/2 inch minimum. All outdoor insulation must be UV and ozone resistant.
6. Consult factory for any exceptions to the above guidelines.

AIR COOLED PIPING SCHEMATIC

LIEBERT® MCV WITHOUT RECEIVER MOUNTED BELOW LIEBERT® XDM

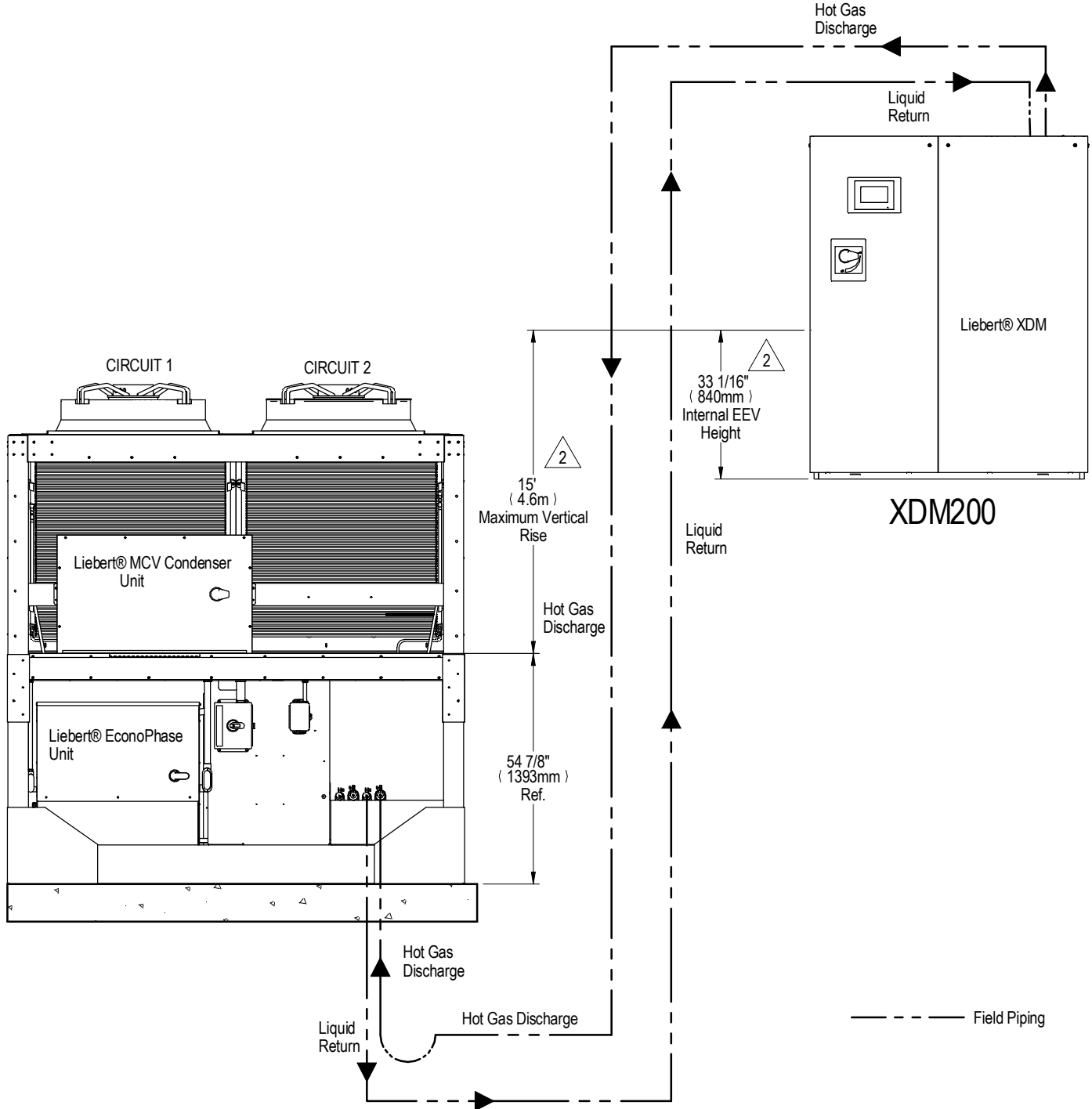

Notes:

1. Single refrigerant circuit shown for clarity, for XDM400 units refrigerant connections are typical.
2. The bottom of the condenser coil cannot be more than 15' (4.6m) below the elevation of the EEVs inside the indoor unit.
3. Unit must be trapped at bottom of riser with any rise over 5 feet (1.5m) high. If rise exceeds 25 feet (7.5m), then a trap is required in 20 foot (6.1m) increments or evenly divided.
4. Pitch horizontal hot gas piping at a minimum of 1/2 inch per 10 feet (42mm per 10m) so that gravity will aid in moving oil in the direction of the refrigeration flow.
5. All indoor and outdoor field refrigerant piping must be insulated, 1/2 inch minimum. All outdoor insulation must be UV and ozone resistant.
6. Consult factory for any exceptions to the above guidelines.



LIEBERT® HEAT REJECTION SKID

CABINET LIFTING POINTS

LIEBERT® MCV MCV330 + LIEBERT® ECONOPHASE + BASE ASSEMBLY

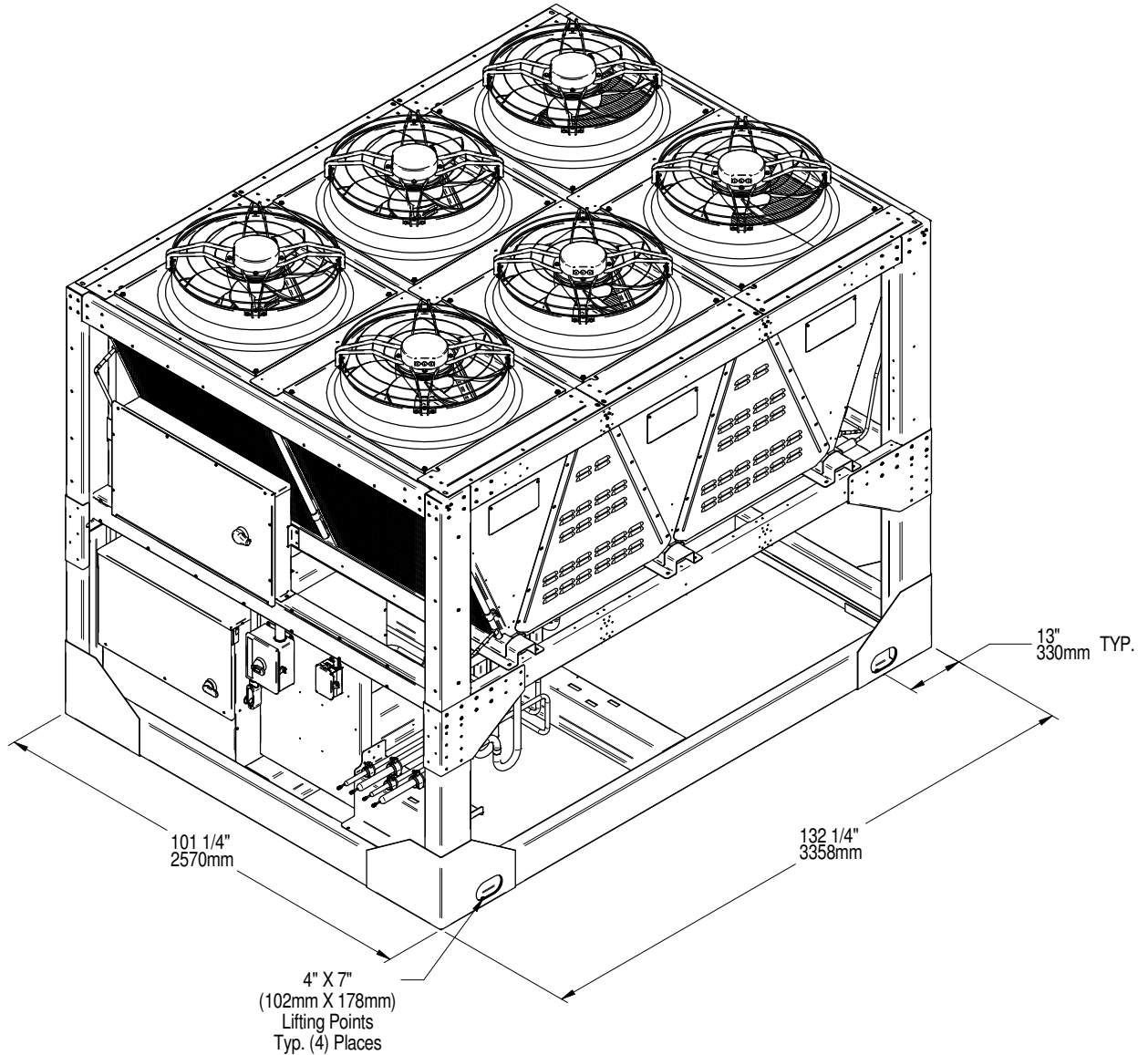

Note:

1. Use indicated lifting points to lift the unit. Use spreader bars and/or shimmed blocks to prevent external damage.
2. Sections must be lifted level. Tilting can cause damage to the equipment inside.
3. Use proper rigging equipment to make sure attachment and lifting at the designated lift points is in the vertical direction.
-Refer to User Manual for site instructions.

LIEBERT® HEAT REJECTION SKID

CABINET LIFTING POINTS LIEBERT® MCV MCV330 (2) + LIEBERT® ECONOPHASE (2) + BASE ASSEMBLY

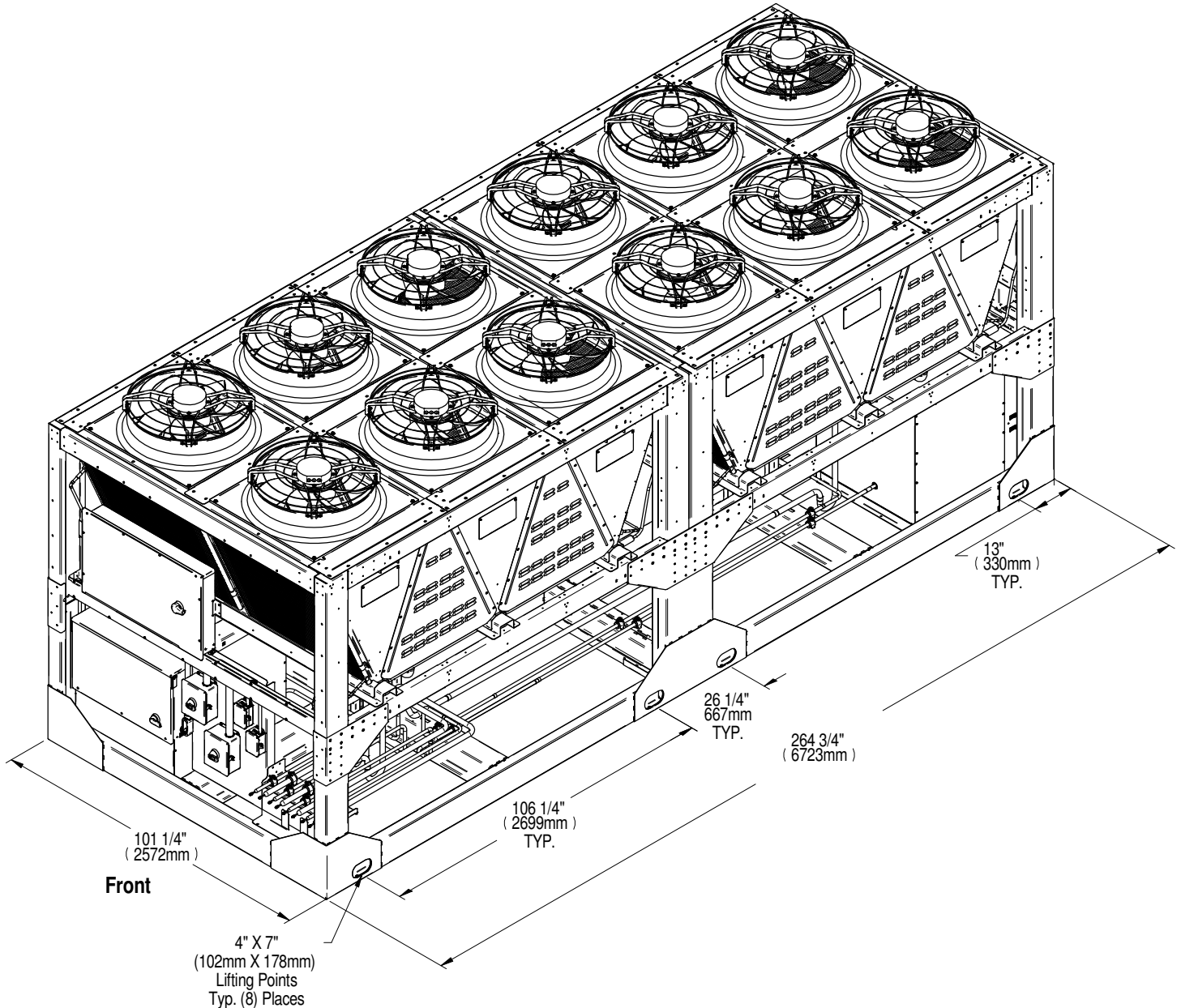

Note:

1. Use indicated lifting points to lift the unit. Use spreader bars and/or shimmed blocks to prevent external damage.
2. Unit must be lifted level. Tilting or twisting can cause damage to internal components.
3. Use proper rigging equipment to make sure attachment and lifting at the designated lift points is in the vertical direction.
-Refer to User Manual for site instructions.



LIEBERT® HEAT REJECTION SKID

CABINET LIFTING POINTS

LIEBERT® MCV MCV440 + LIEBERT® ECONOPHASE + BASE ASSEMBLY

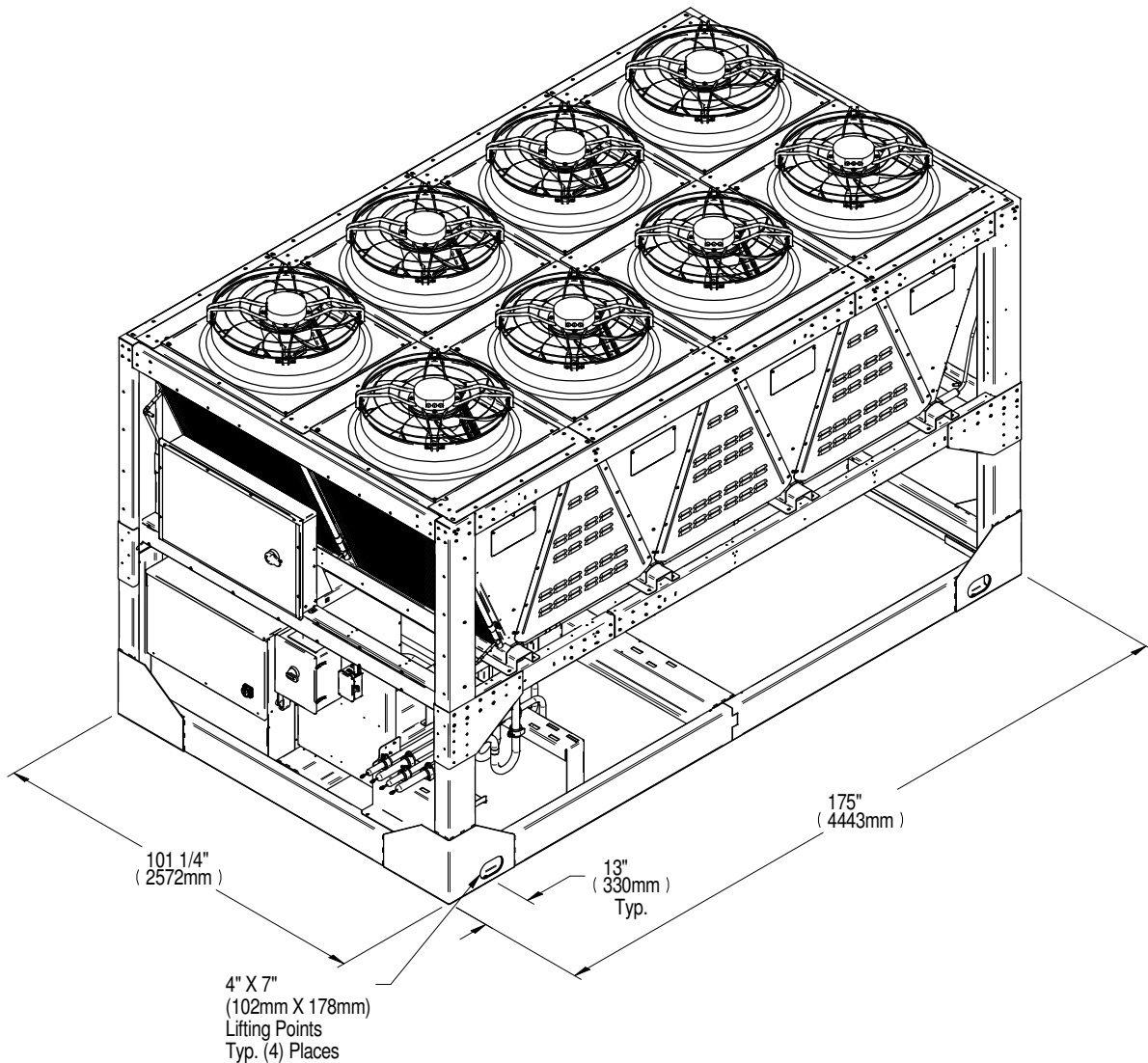

Notes:

1. Use indicated lifting points to lift the unit. Use spreader bars and/or shimmed blocks to prevent external damage.
2. Unit must be lifted level. Tilting can cause damage to the equipment inside.
3. Use proper rigging equipment to make sure attachment and lifting at the designated lift points is in the vertical direction.
-Refer to User Manual for site instructions.



LIEBERT® HEAT REJECTION SKID

CABINET LIFTING POINTS

LIEBERT® MCV MCV440 (2) + LIEBERT® ECONOPHASE (2)
+ BASE ASSEMBLY

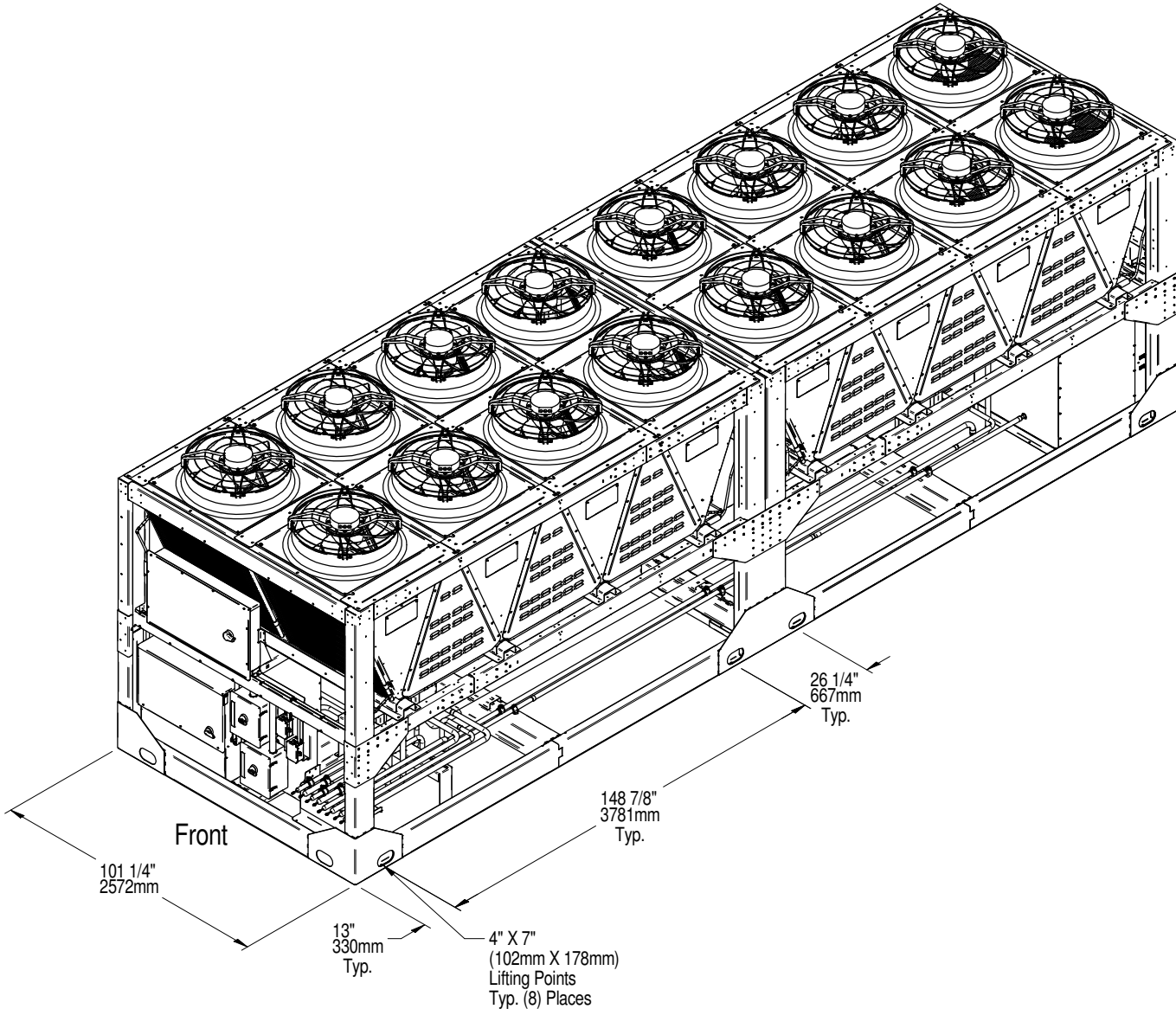

Note:

1. Use indicated lifting points to lift the unit. Use spreader bars and/or shimmed blocks to prevent external damage.
2. Unit must be lifted level. Tilting or twisting can cause damage to internal components.
3. Use proper rigging equipment to make sure attachment and lifting at the designated lift points is in the vertical direction.
-Refer to User Manual for site instructions.

PIPING SCHEMATIC

DA125, DA150, DA165 & DA250 W/ LIEBERT® MCV WITH RECEIVERS

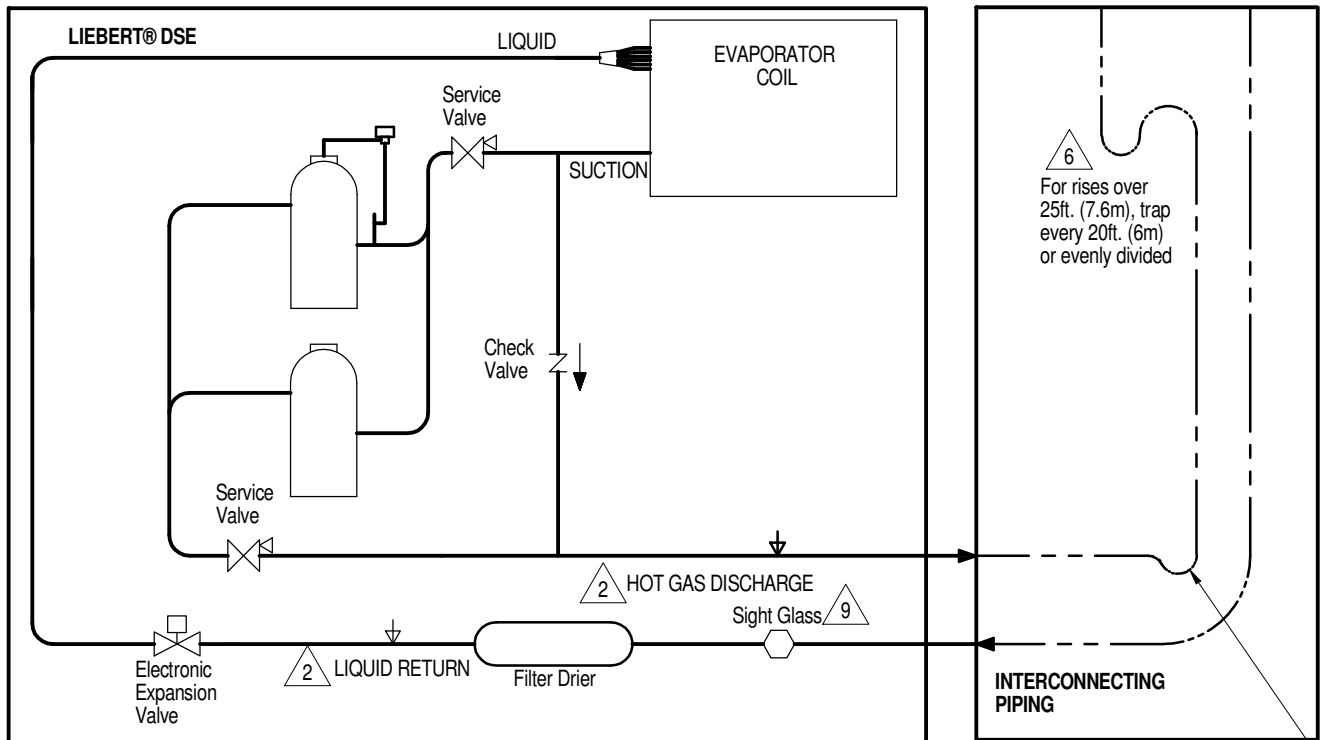
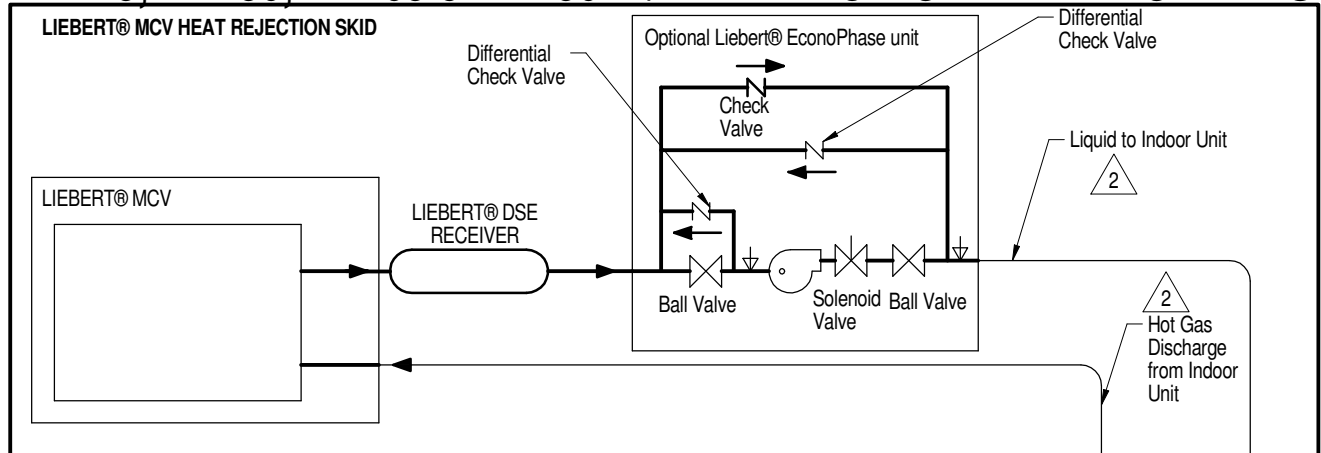

- FACTORY REFRIGERANT PIPING
- - - - - FIELD PIPING
- ▽ SERVICE/SCHRADER (ACCESS) CONNECTION, NO VALVE CORE.
- ▽ SERVICE/SCHRADER (ACCESS) CONNECTION, WITH VALVE CORE.
- △ 6 Trap at base of risers over 5ft. (1.5m)

- Notes:
1. Two refrigeration circuits provided. Single refrigeration circuit shown for clarity.
 2. Circuit 1 must be maintained between indoor unit, condenser and Liebert® EconoPhase unit. Circuit 2 must be maintained between indoor unit, condenser and Liebert® EconoPhase unit.
 3. Schematic representation shown. Do not use for specific connection locations.
 4. The outlet of the receiver must be higher than the elevation of the EEV inside the indoor unit. This vertical height must not exceed 60ft. (18.3m). Liebert® DSE Receiver required for systems with or without Liebert® EconoPhase unit.
 5. All indoor field refrigerant piping must be insulated, 1/2" minimum thickness. All outdoor field refrigeration piping does not need to be insulated. The installing contractor is responsible for the insulating, securing, protecting and the proper installation of all field refrigerant piping, observing the details outlined by the Engineer of Record.
 6. Components are not supplied by Vertiv but are required for proper circuit operation and maintenance (DA250 with top piping has internally installed traps on the discharge lines).
 7. Traps must be installed and horizontal lines pitched to ensure proper oil return and to reduce liquid flood back to compressor. Pitch horizontal gas piping at a minimum of 1/2" per 10 feet (42mm per 10m) so that gravity will aid in moving oil in the direction of the refrigeration flow.
 8. Do not isolate any refrigeration circuits from over pressurization protection.
 9. Typical location for Sight Glass on DA150 and DA165. On DA125 and DA250, Sight Glass is located between Filter Drier and Electronic Expansion Valve.

PIPING SCHEMATIC

DA125, DA150, DA165, DA250, & DA265 W/ LIEBERT® MCV WITHOUT RECEIVERS

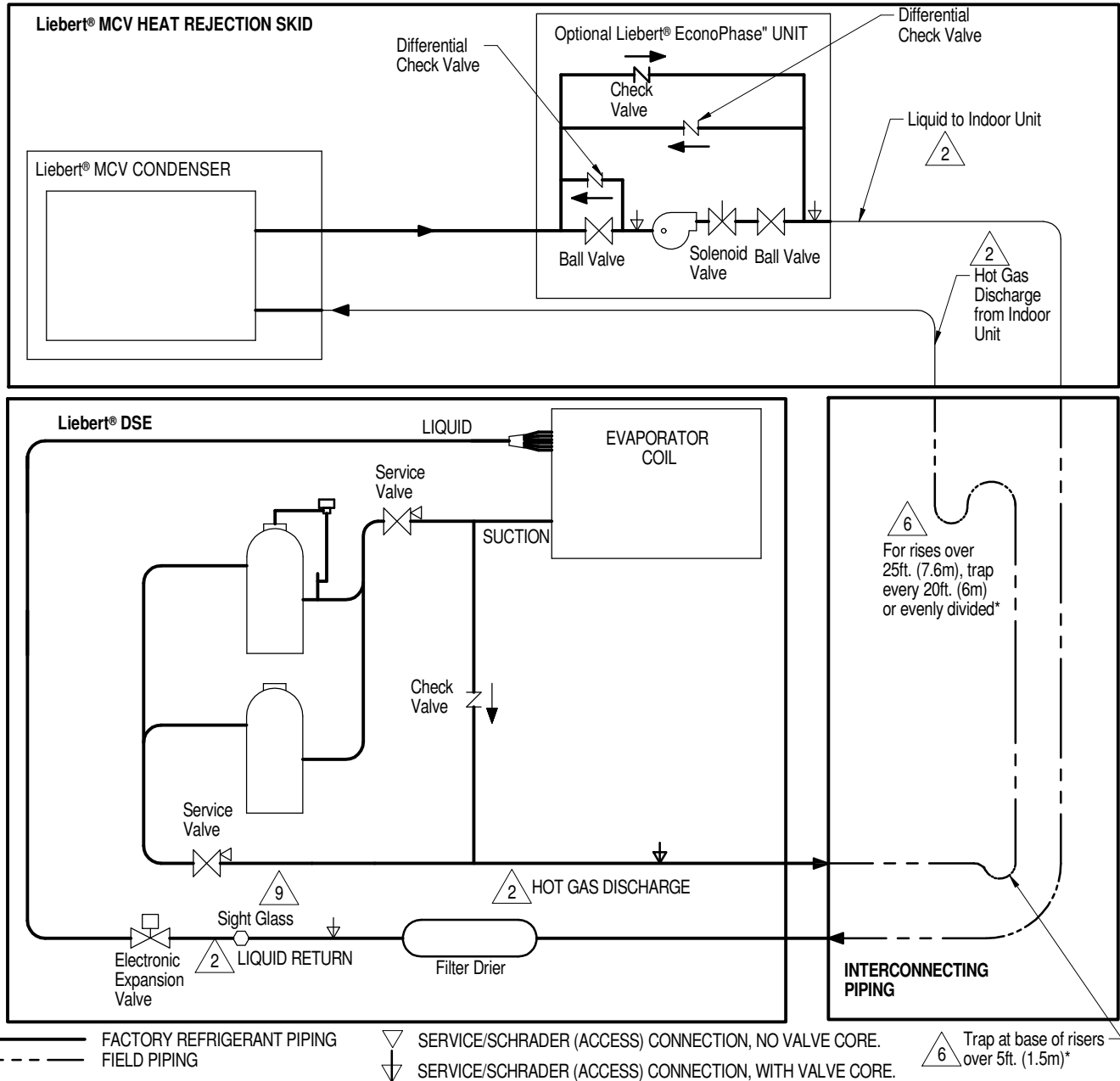



Notes:

- Two refrigeration circuits provided. Single refrigeration circuit shown for clarity.
- △ Circuit 1 must be maintained between indoor unit, condenser and EconoPhase unit. Circuit 2 must be maintained between indoor unit, condenser and Liebert® EconoPhase unit.
- Schematic representation shown. Do not use for specific connection locations.
- The bottom of the condenser coil must be no greater than 60 ft (18.3m) above and less than 15 ft (4.6m) below the elevation of the EEV inside the indoor unit.
- All indoor field refrigerant piping must be insulated, 1/2" minimum thickness. All outdoor field refrigeration piping does not need to be insulated. The installing contractor is responsible for the insulating, securing, protecting and the proper installation of all field refrigerant piping, observing the details outlined by the Engineer of Record.
- △ Components are not supplied by Liebert but are required for proper circuit operation and maintenance (DA250 and DA265 with top piping has internally installed traps on the discharge lines).
- Traps must be installed and horizontal lines pitched to ensure proper oil return and to reduce liquid flood back to compressor. Pitch horizontal gas piping at a minimum of 1/2" per 10 feet (42mm per 10m) so that gravity will aid in moving oil in the direction of the refrigeration flow.
- Do not isolate any refrigeration circuits from over pressurization protection.
- △ Typical location for Sight Glass on DA125, DA250, and DA265. On DA150 and DA165, Sight Glass is located between Filter Drier and customer piping connection.

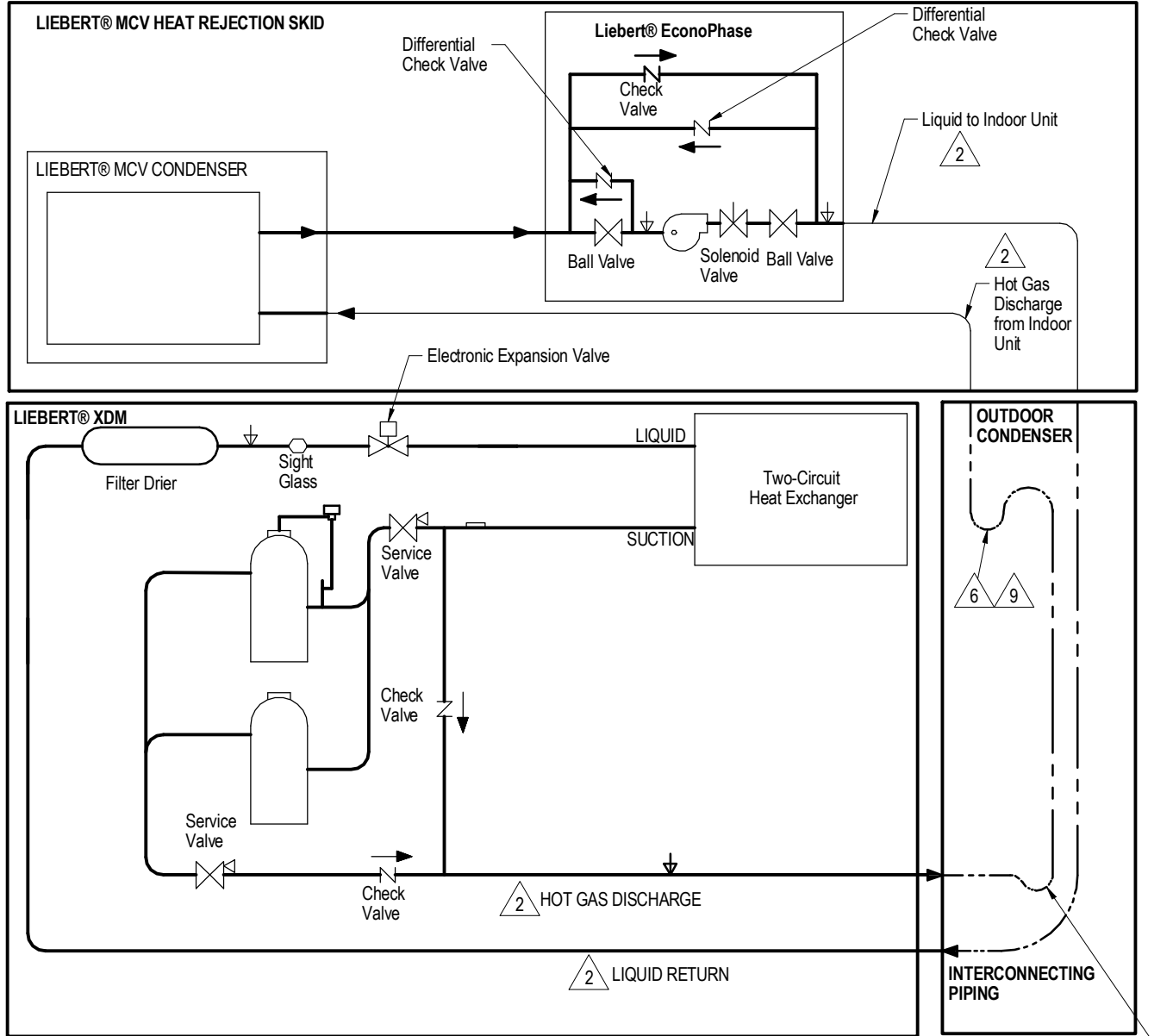
PIPING SCHEMATIC
LIEBERT® XDM with LIEBERT® MCV



FACTORY REFRIGERANT PIPING  SERVICE/SCHRADER (ACCESS) CONNECTION, NO VALVE CORE.
 FIELD PIPING  SERVICE/SCHRADER (ACCESS) CONNECTION, WITH VALVE CORE.

Notes:

1. Two refrigeration circuits provided. Single refrigeration circuit shown for clarity.
2. Circuit 1 must be maintained between indoor unit, condenser and Liebert® EconoPhase unit. Circuit 2 must be maintained between indoor unit, condenser and EconoPhase unit.
3. Schematic representation shown. Do not use for specific connection locations.
4. The bottom of the condenser coil must be less than 60' (18.3m) above and cannot be more than 15 ft (4.6m) below the elevation of the EEVs inside the indoor unit.
5. All indoor and outdoor field refrigerant piping must be insulated, 1/2" minimum thickness. All outdoor insulation must be UV and ozone resistant.
6. Components are not supplied by Liebert but are required for proper circuit operation and maintenance.
7. Traps must be installed and horizontal lines pitched to ensure proper oil return and to reduce liquid flood back to compressor. Pitch horizontal gas piping at a minimum of 1/2" per 10 feet (42mm per 10m) so that gravity will aid in moving oil in the direction of the refrigeration flow.
8. Do not isolate any refrigeration circuits from over pressurization protection.
9. For rises over 25ft. (7.6m), trap every 20ft. (6m) or evenly divided

**PIPING SCHEMATIC
LIEBERT® XDM CHILLED WATER SIDE**

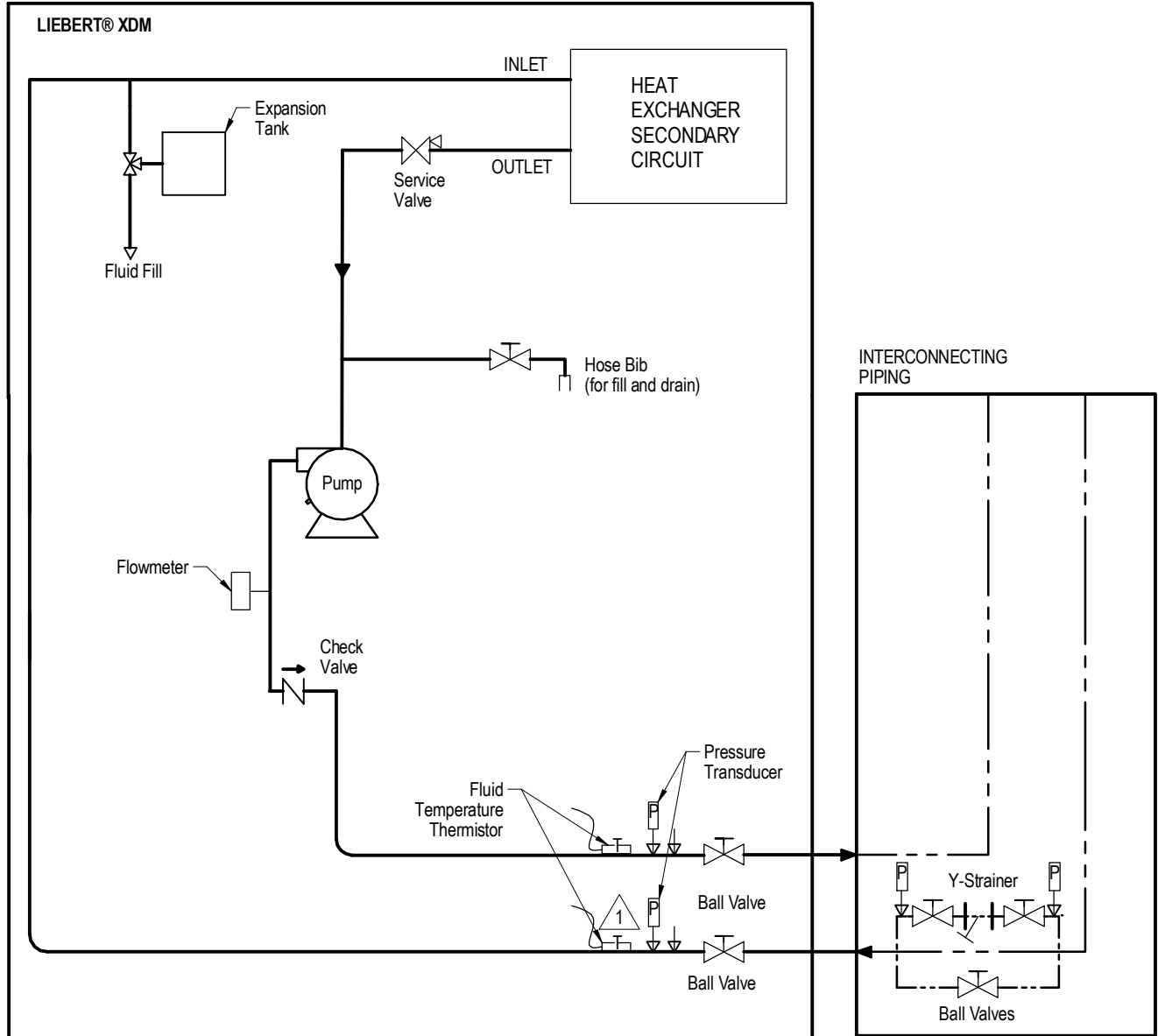

————— FACTORY WATER PIPING
 - - - - - FIELD PIPING
 - · - · - · - - OPTIONAL PIPING

▽ SERVICE/SCHRADER (ACCESS) CONNECTION, NO VALVE CORE.
 ▽ SERVICE/SCHRADER (ACCESS) CONNECTION, WITH VALVE CORE.

Notes:

1. Supply and Return connections in Liebert® XDM having temperature sensor, pressure transducer, schrader air vent, and ball valve.
2. Field to install strainer in field secondary (XDM) return line to Cooling Modules. Vertiv recommends a bypass piping arrangement to allow for cleaning the strainer without disrupting unit operation. Also pressure taps across the strainer to check pressure drop. Three full port ball valves, pressure taps and piping are supplied by the field. The maximum distance of this assembly is 10 feet from the Liebert® XDM Unit.



LIEBERT® HEAT REJECTION SKID

PRIMARY CONNECTION LOCATIONS LIEBERT® MCV330 + LIEBERT® ECONOPHASE + BASE ASSY 460V & 575V

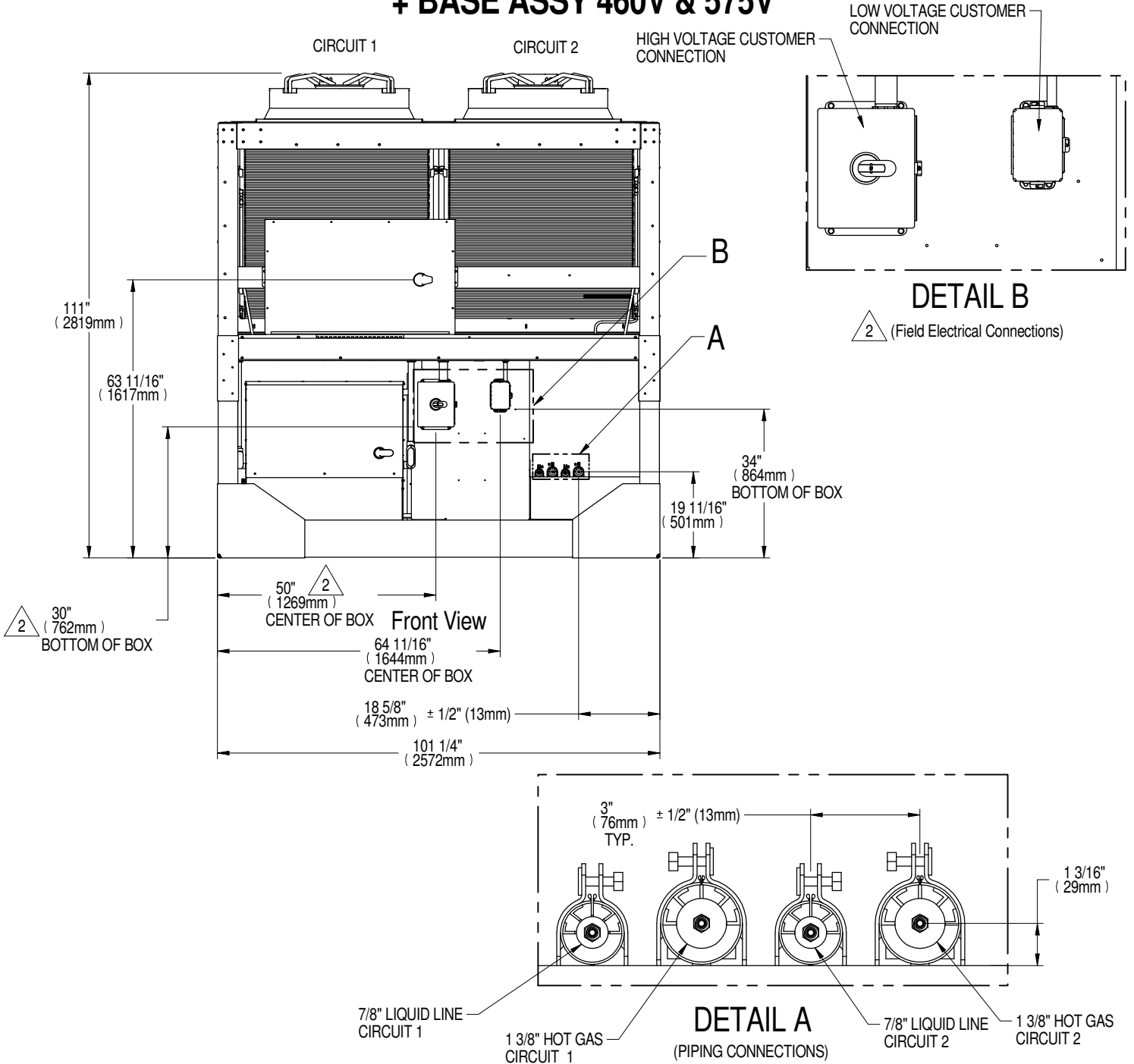

Notes:
1. Field to provide hole for conduit for high voltage disconnect box and low voltage distribution panel.

2. High Voltage Customer Connection for:
Voltage Codes: A=(460V/3 Phase/60Hz); B=(575V/3 Phase/60Hz)



LIEBERT® HEAT REJECTION SKID

PRIMARY CONNECTION LOCATIONS LIEBERT® MCV330 + LIEBERT® ECONOPHASE + BASE ASSY 380V & 415V

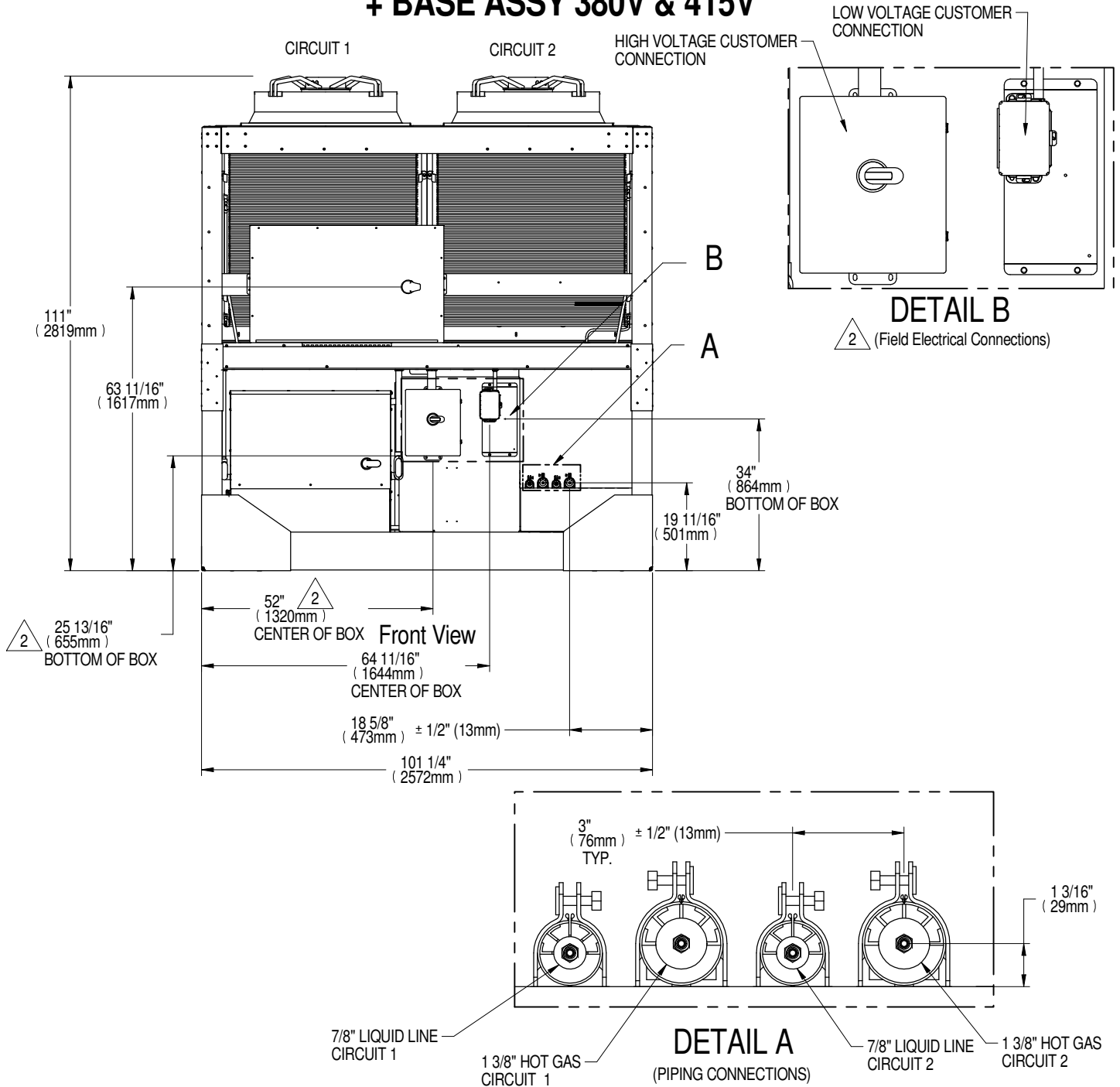

- Notes:
- Field to provide hole for conduit for high voltage disconnect box and low voltage distribution panel.
 - High Voltage Customer Connection for:
Voltage Codes: 2=(380V/3 Phase/60Hz); G=(415V/3 Phase/50Hz)



LIEBERT® HEAT REJECTION SKID

PRIMARY CONNECTION LOCATIONS LIEBERT® MCV330 (2) + LIEBERT® ECONOPHASE (2) + BASE ASSY 380V & 415V

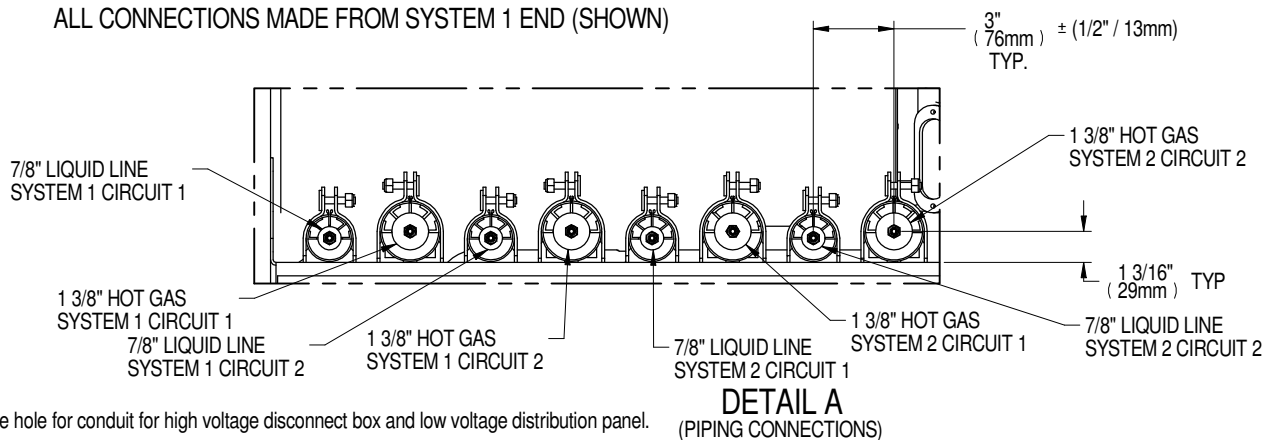
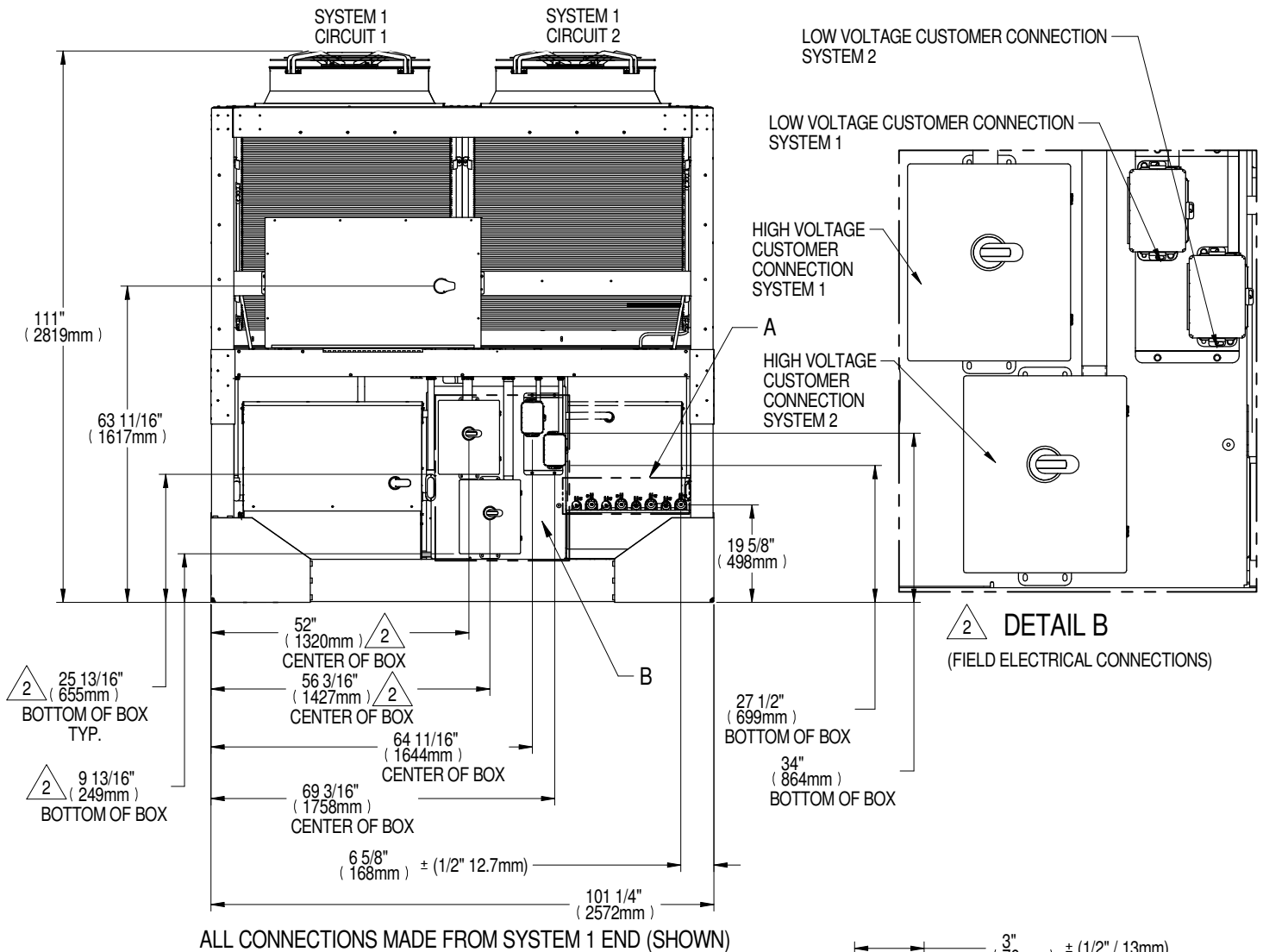

Notes:

1. Field to provide hole for conduit for high voltage disconnect box and low voltage distribution panel.

2. High Voltage Customer Connection for:
Voltage Codes: 2=(380V/3 Phase/60Hz); G=(415V/3 Phase/50Hz)



LIEBERT® HEAT REJECTION SKID

PRIMARY CONNECTION LOCATIONS LIEBERT® MCV330 (2) + LIEBERT® ECONOPHASE (2) + BASE ASSY 460V & 575V

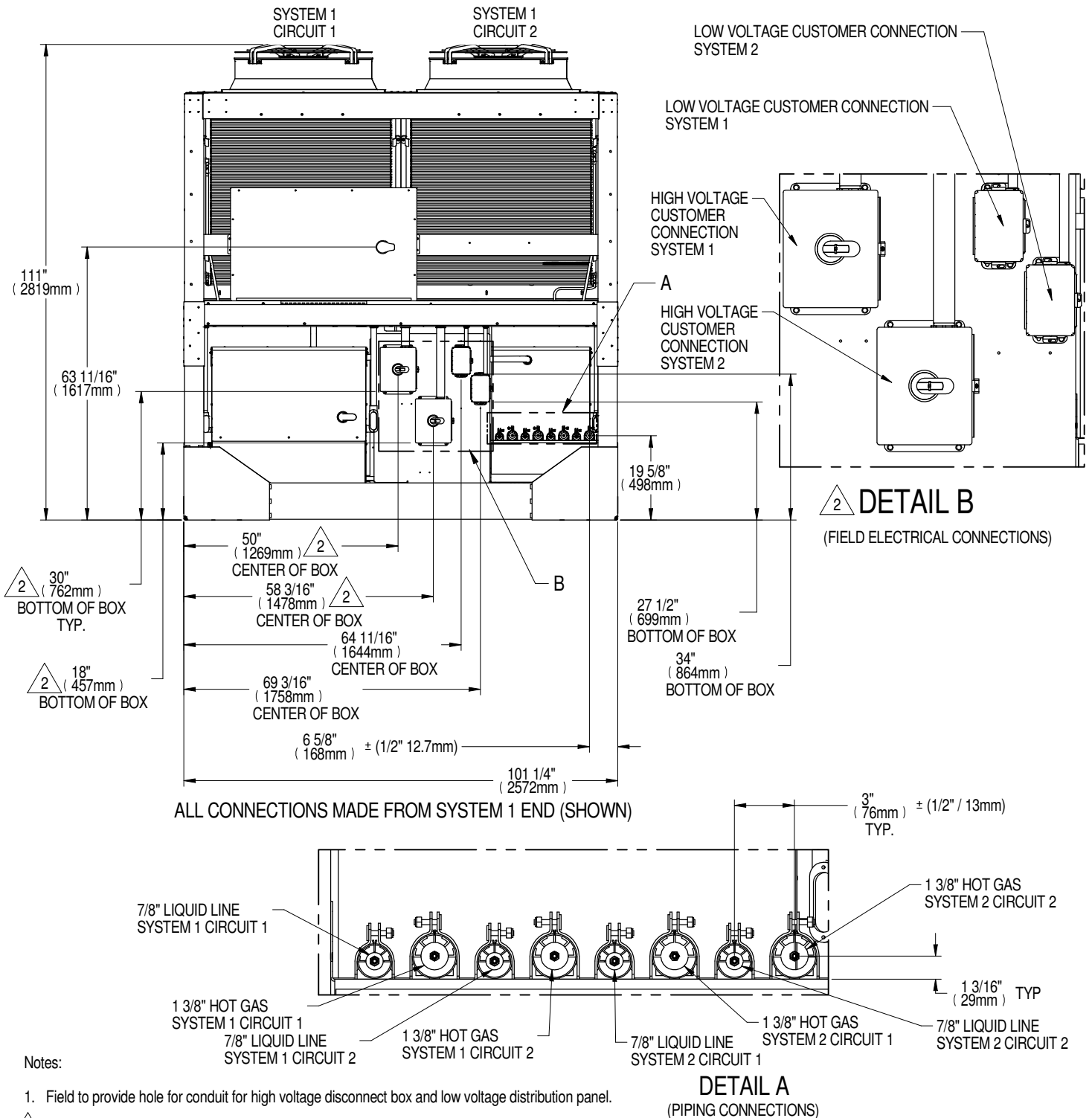

- Notes:
1. Field to provide hole for conduit for high voltage disconnect box and low voltage distribution panel.

2. High Voltage Customer Connection for:
Voltage Codes: A=(460V/3 Phase/60Hz); B=(575V/3 Phase/60Hz)

Form No.: DPN001040_REV14



LIEBERT® HEAT REJECTION SKID

PRIMARY CONNECTION LOCATIONS

LIEBERT® MCV440 + LIEBERT® ECONOPHASE + BASE ASSEMBLY

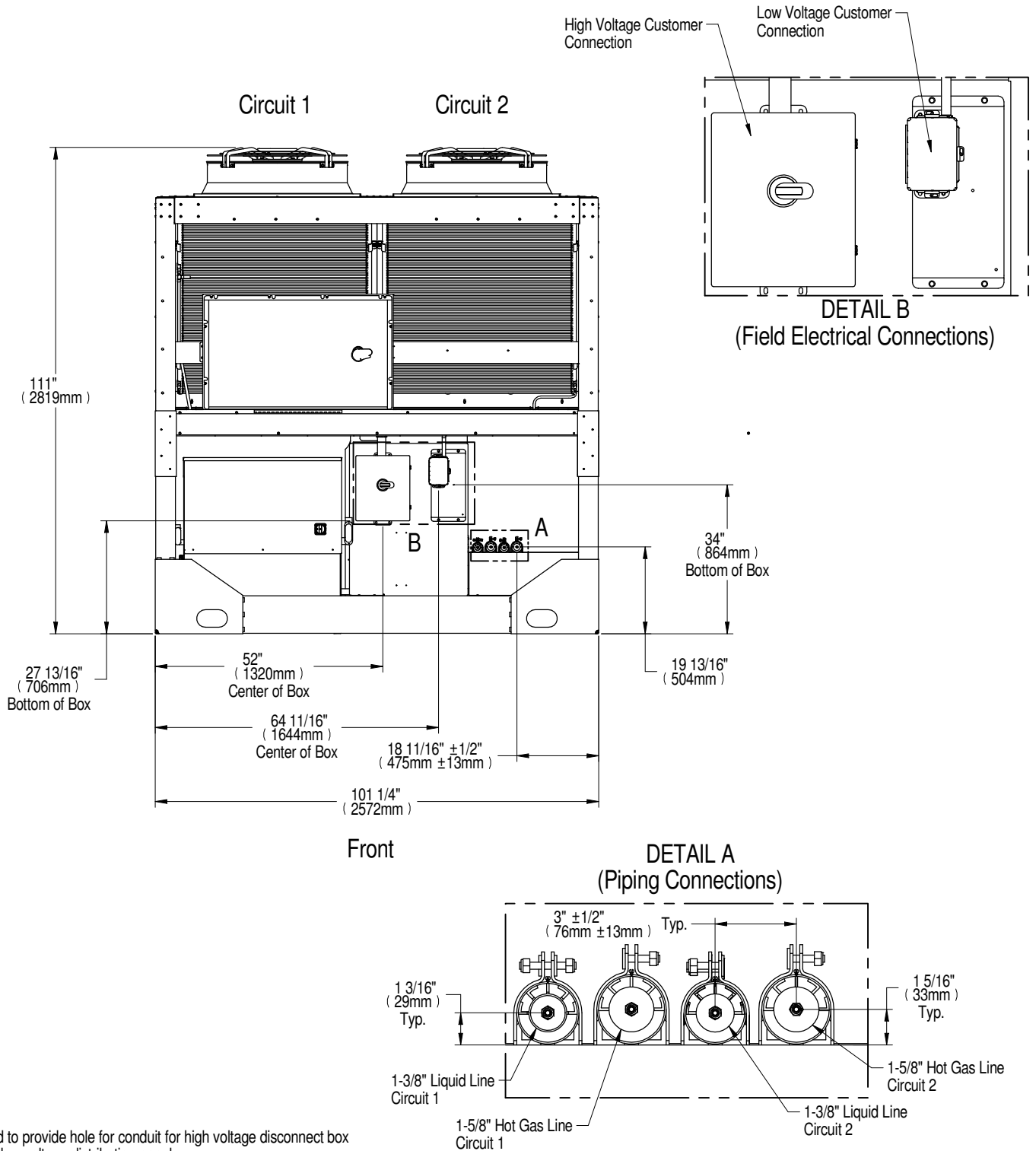

Notes:
1. Field to provide hole for conduit for high voltage disconnect box and low voltage distribution panel.

LIEBERT® HEAT REJECTION SKID

PRIMARY CONNECTION LOCATIONS LIEBERT® MCV440 (2) + LIEBERT® ECONOPHASE (2) + BASE ASSEMBLY

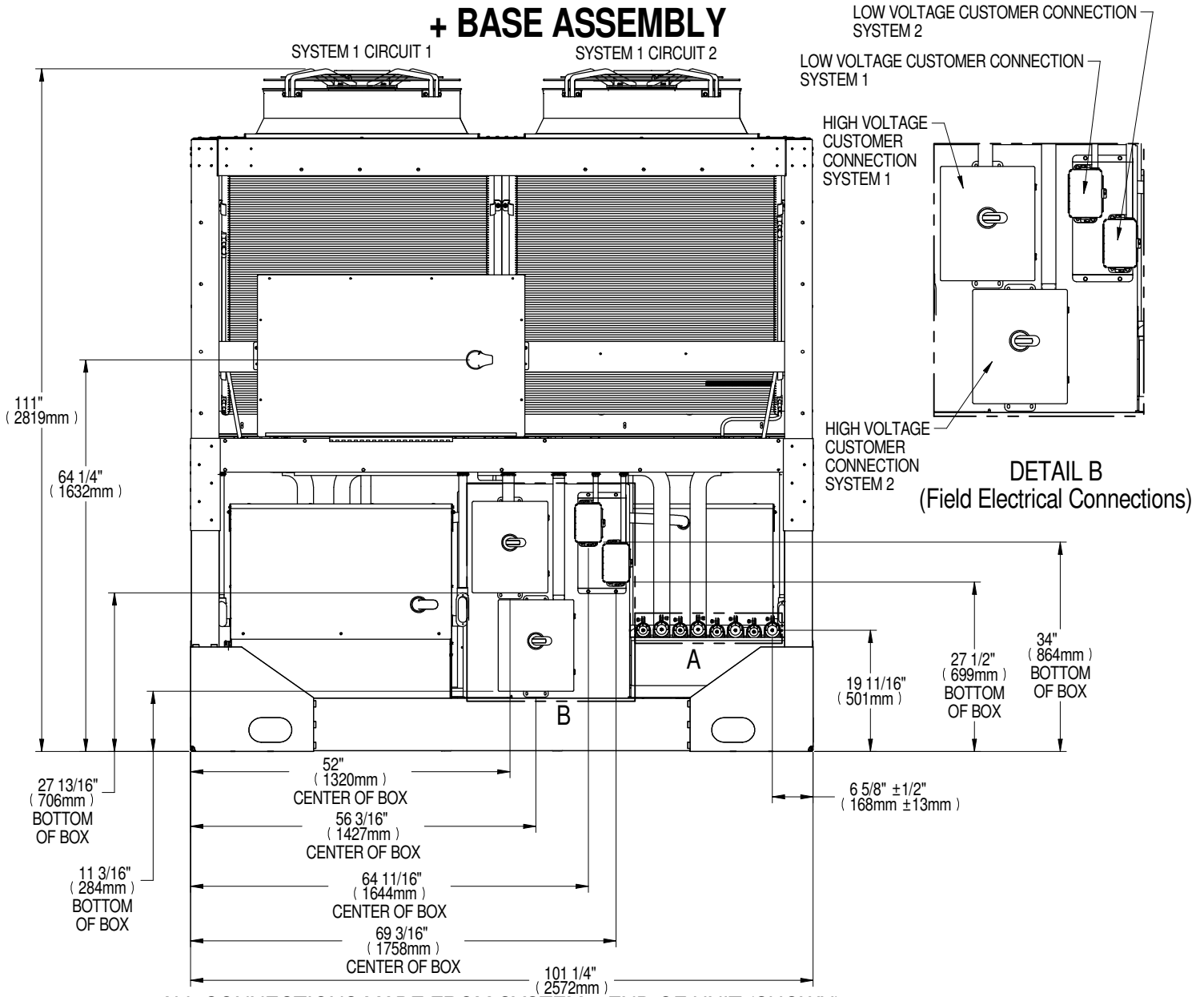

ALL CONNECTIONS MADE FROM SYSTEM 1 END OF UNIT (SHOWN)

DETAIL A (PIPING CONNECTIONS)

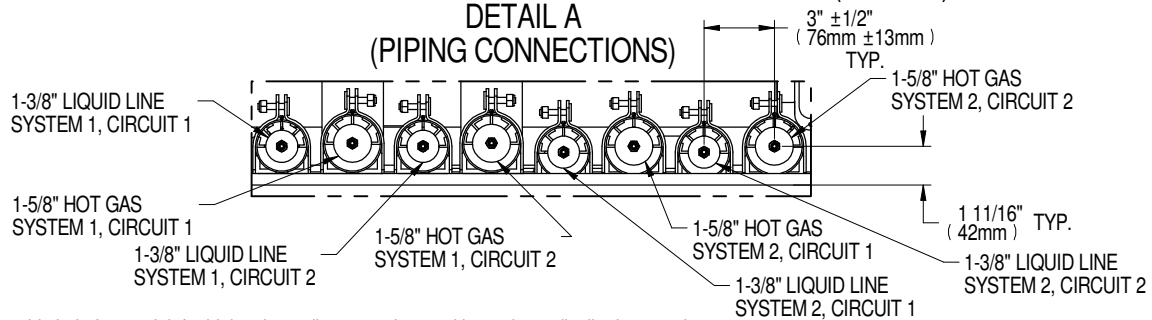

Notes:

- Field to provide hole for conduit for high voltage disconnect box and low voltage distribution panel.

ELECTRICAL PANEL LAYOUT MCV330

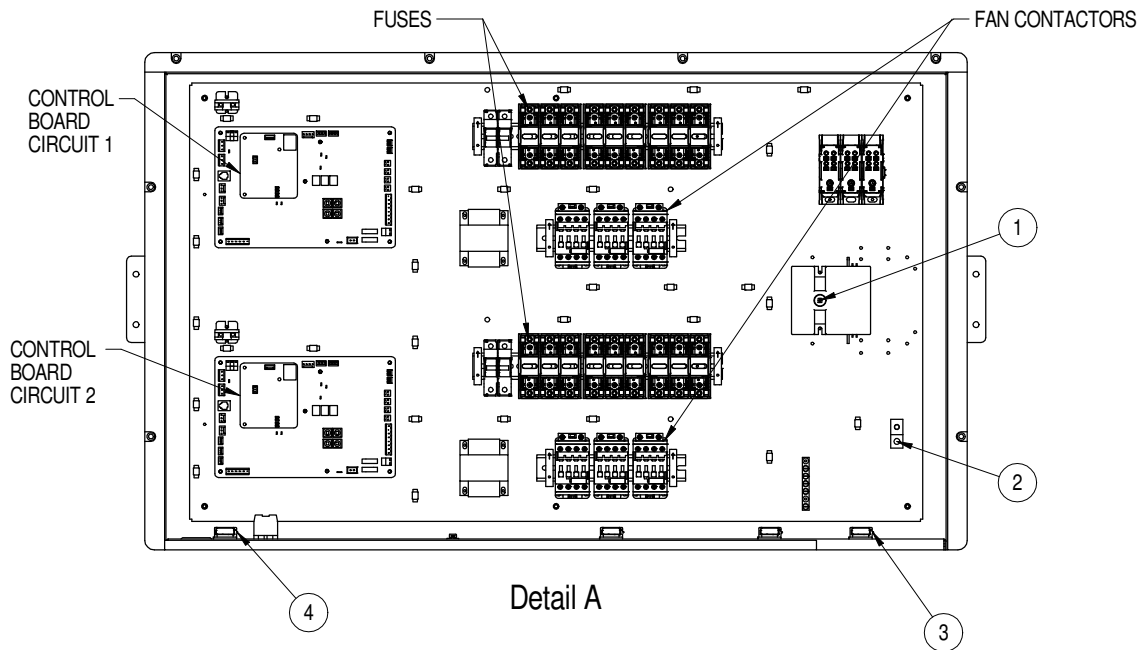
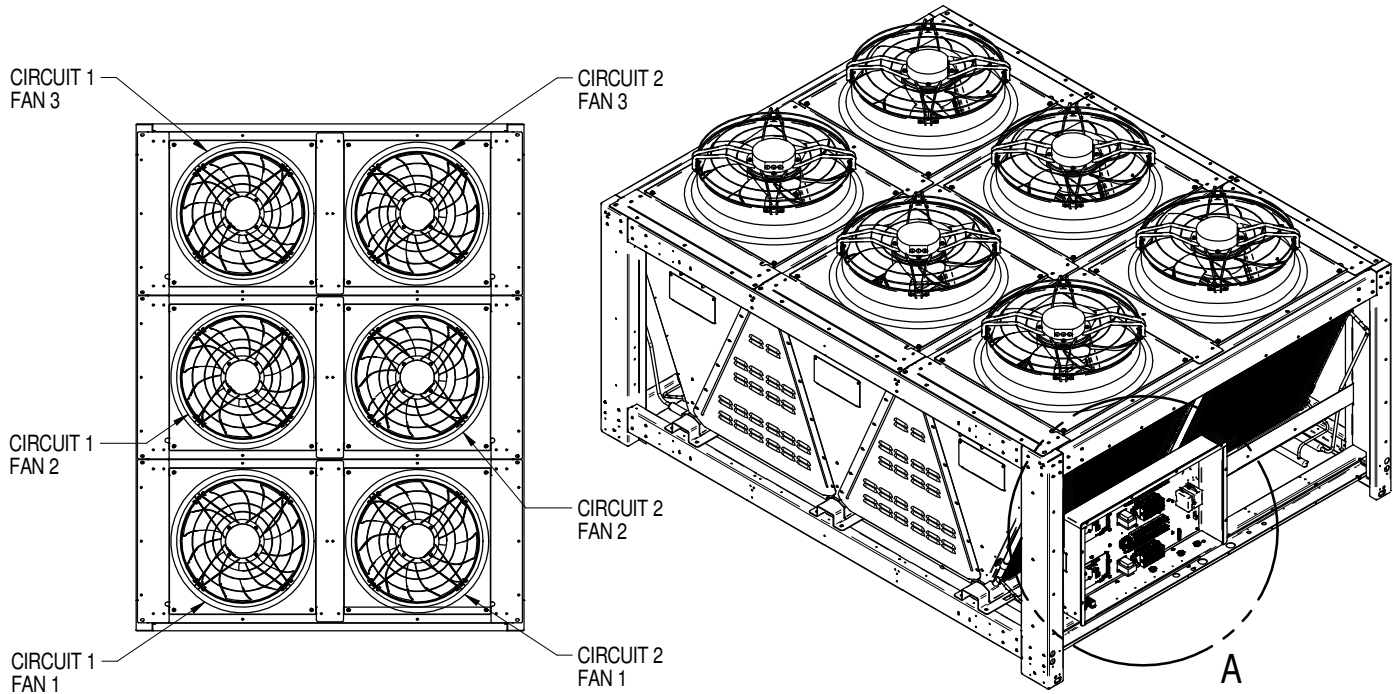

KEY ELECTRICAL DETAILS:

- 1) Three phase electrical service – Terminals are on bottom of disconnect switch. Three phase service not by Liebert.
- 2) Earth ground – Field lug terminal for earth ground connection.
- 3) High voltage entrance located at the bottom of the enclosure.
- 4) Low voltage entrance located at the bottom of the enclosure.

ELECTRICAL PANEL LAYOUT MCV440

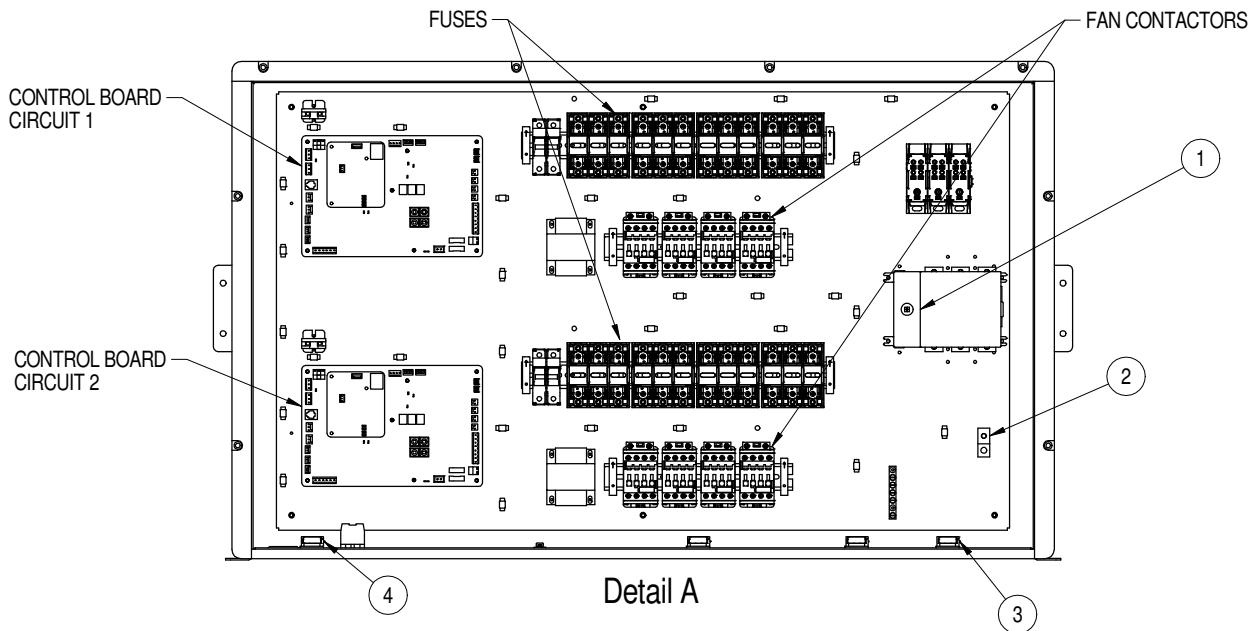
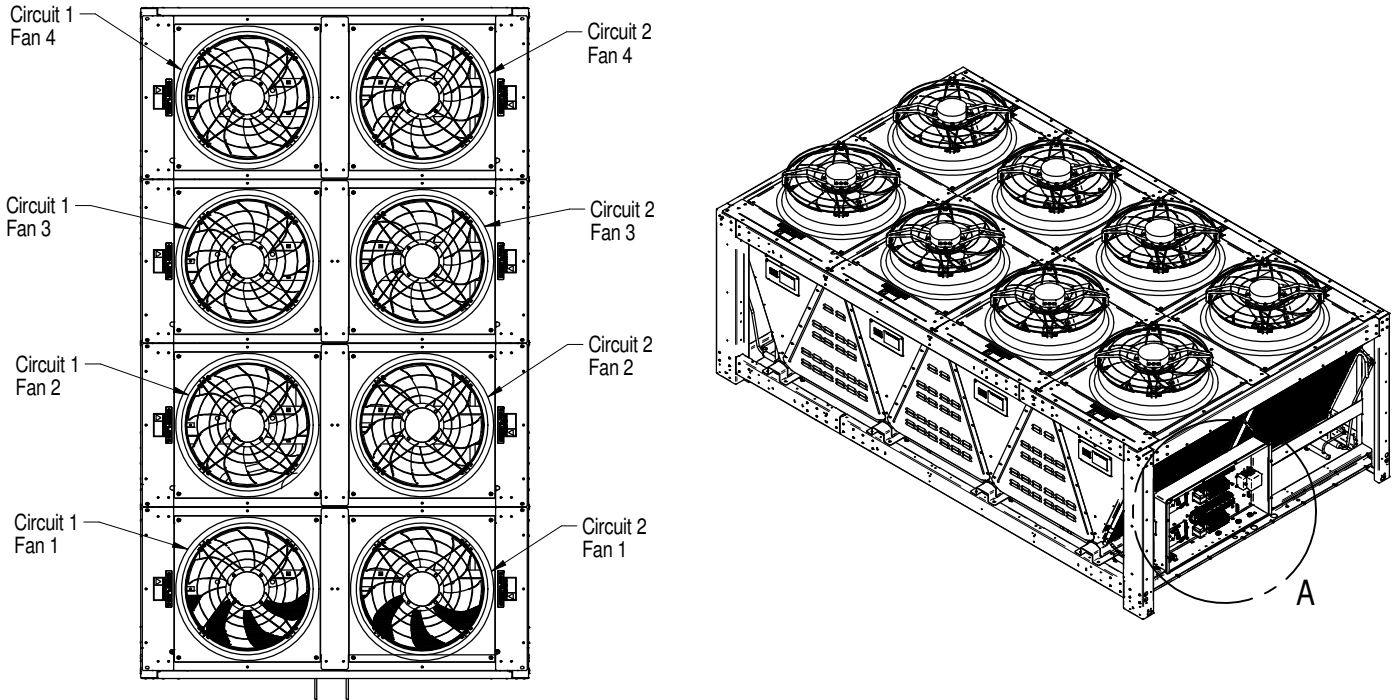

KEY ELECTRICAL DETAILS:

- 1) Three phase electrical service – Terminals are on bottom of disconnect switch. Three phase service not by Liebert.
- 2) Earth ground – Field lug terminal for earth ground connection.
- 3) High voltage entrance located at the bottom of the enclosure.
- 4) Low voltage entrance located at the bottom of the enclosure.



LIEBERT® HEAT REJECTION SKID

PRIMARY CONNECTION LOCATIONS LIEBERT® MCV330 + LIEBERT® ECONOPHASE + BASE ASSY 460V & 575V

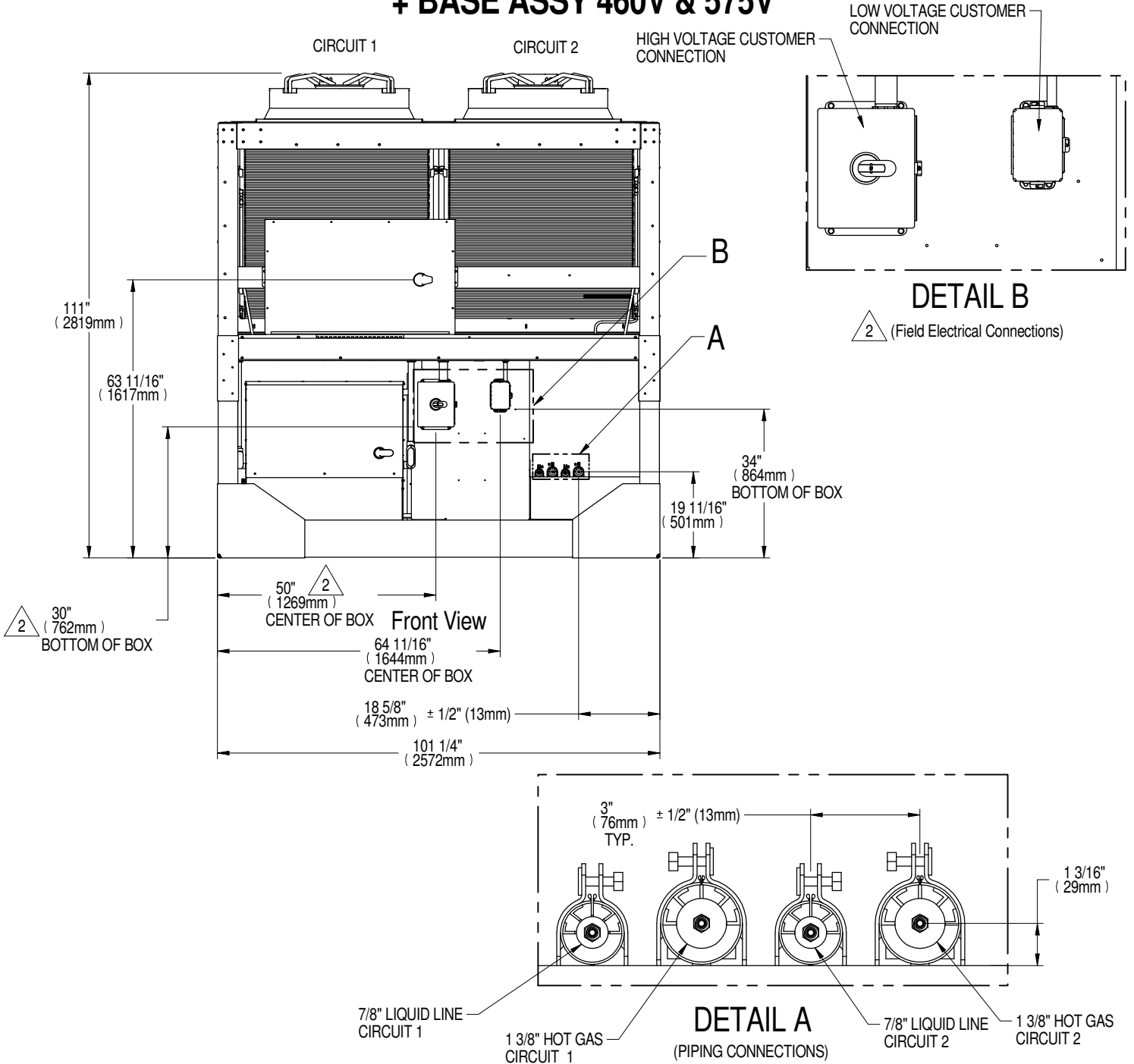

Notes:
1. Field to provide hole for conduit for high voltage disconnect box and low voltage distribution panel.

2. High Voltage Customer Connection for:
Voltage Codes: A=(460V/3 Phase/60Hz); B=(575V/3 Phase/60Hz)



LIEBERT® HEAT REJECTION SKID

PRIMARY CONNECTION LOCATIONS LIEBERT® MCV330 (2) + LIEBERT® ECONOPHASE (2) + BASE ASSY 460V & 575V

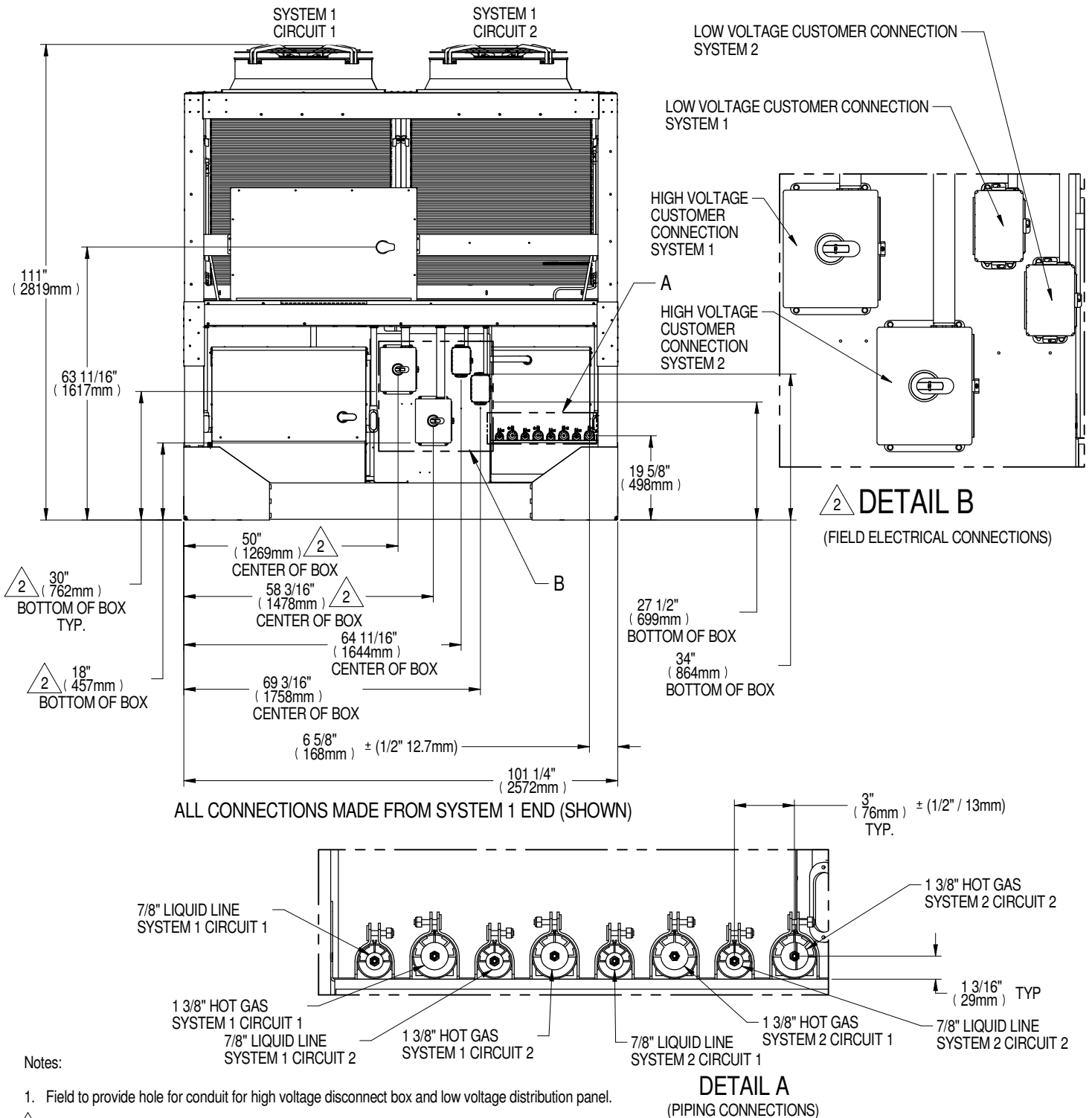

- Notes:
1. Field to provide hole for conduit for high voltage disconnect box and low voltage distribution panel.

2. High Voltage Customer Connection for:
Voltage Codes: A=(460V/3 Phase/60Hz); B=(575V/3 Phase/60Hz)

Form No.: DPN001040_REV14



LIEBERT® HEAT REJECTION SKID

PRIMARY CONNECTION LOCATIONS LIEBERT® MCV330 + LIEBERT® ECONOPHASE + BASE ASSY 380V & 415V

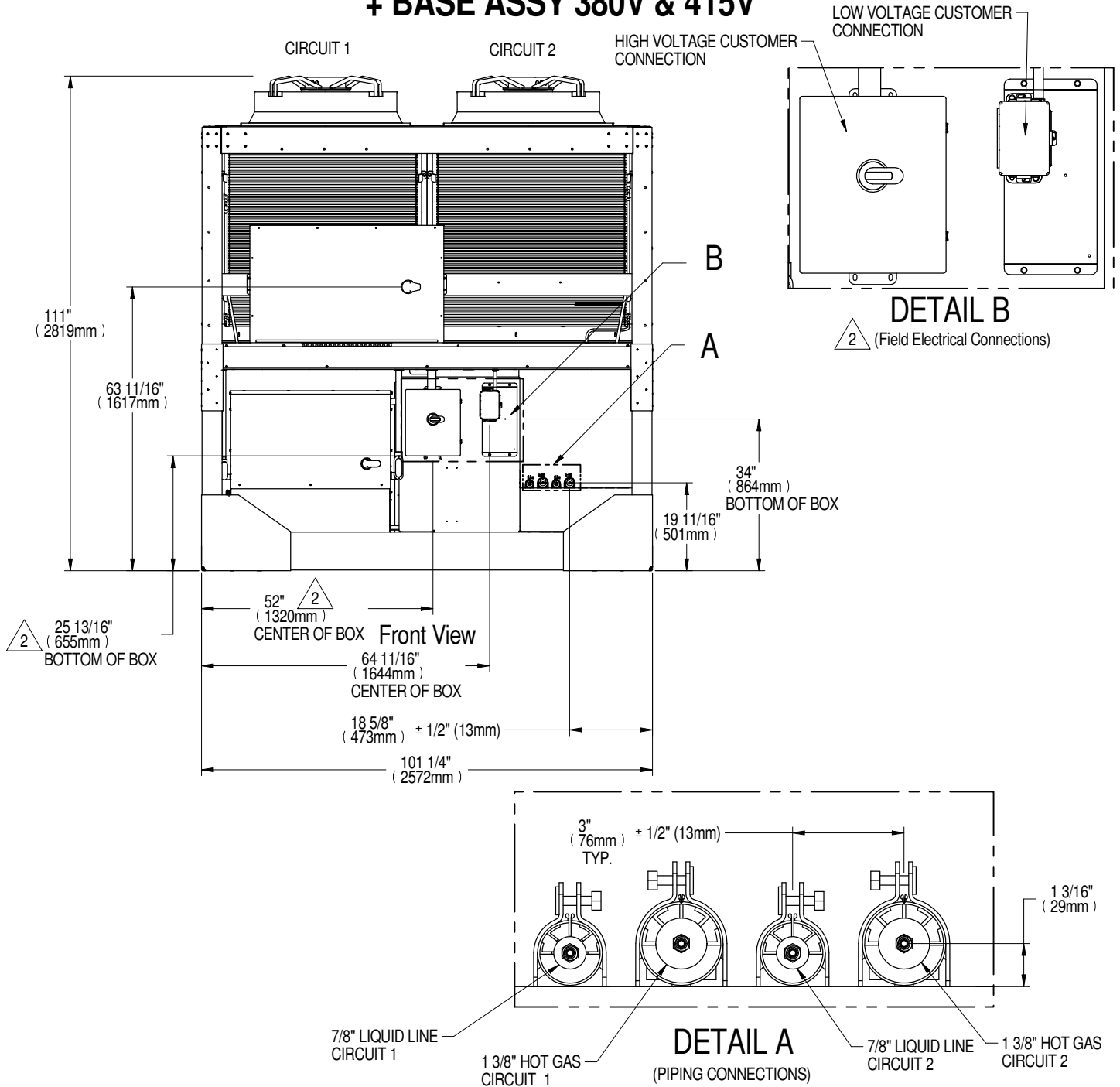

Notes:
1. Field to provide hole for conduit for high voltage disconnect box and low voltage distribution panel.

2. High Voltage Customer Connection for:
Voltage Codes: 2=(380V/3 Phase/60Hz); G=(415V/3 Phase/50Hz)



LIEBERT® HEAT REJECTION SKID

PRIMARY CONNECTION LOCATIONS LIEBERT® MCV330 (2) + LIEBERT® ECONOPHASE (2) + BASE ASSY 380V & 415V

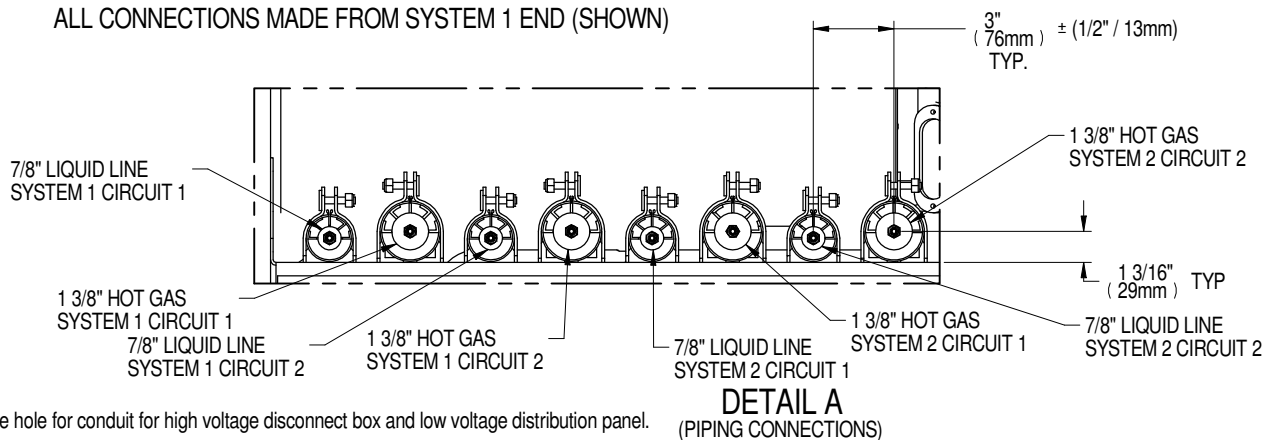
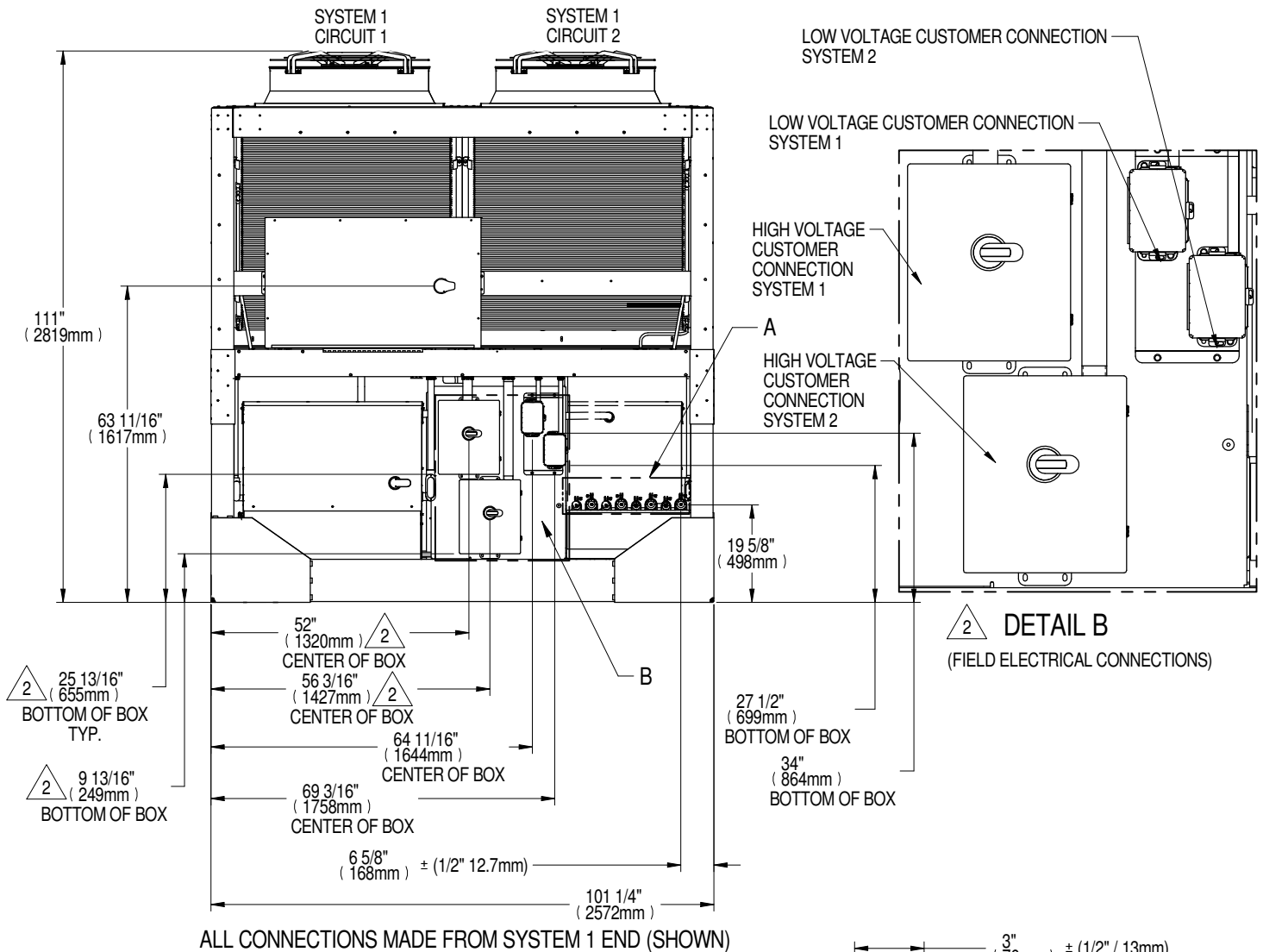

Notes:

1. Field to provide hole for conduit for high voltage disconnect box and low voltage distribution panel.

2. High Voltage Customer Connection for:
Voltage Codes: 2=(380V/3 Phase/60Hz); G=(415V/3 Phase/50Hz)



LIEBERT® HEAT REJECTION SKID

PRIMARY CONNECTION LOCATIONS

LIEBERT® MCV440 + LIEBERT® ECONOPHASE + BASE ASSEMBLY

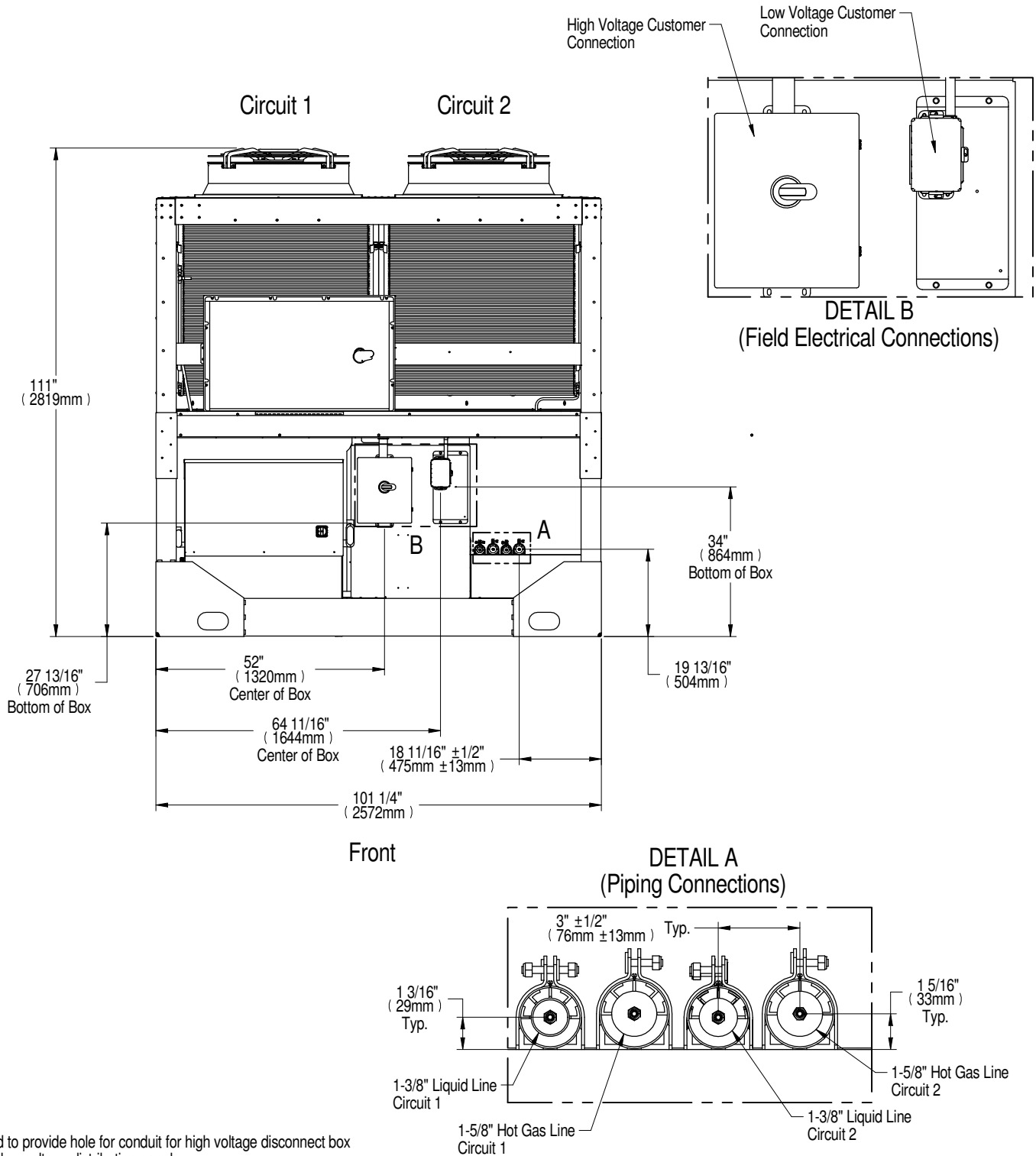

Notes:
 1. Field to provide hole for conduit for high voltage disconnect box and low voltage distribution panel.

Form No.: DPN001040_REV14



LIEBERT® HEAT REJECTION SKID

PRIMARY CONNECTION LOCATIONS LIEBERT® MCV440 (2) + LIEBERT® ECONOPHASE (2) + BASE ASSEMBLY

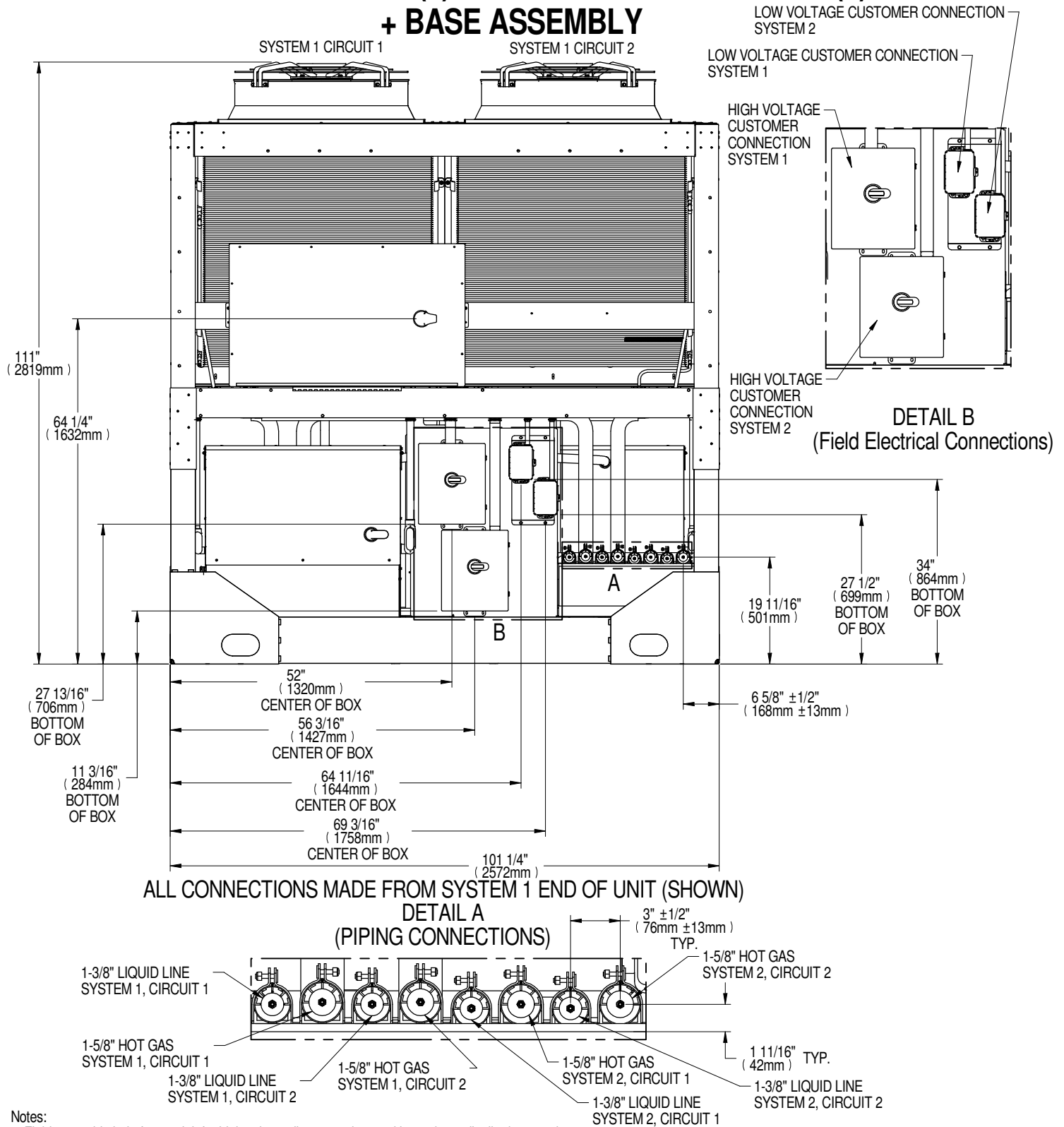

Notes:

1. Field to provide hole for conduit for high voltage disconnect box and low voltage distribution panel.

LIEBERT® HEAT REJECTION SKID

CANbus & INTERLOCK CONNECTIONS LIEBERT® MCV + LIEBERT® ECONOPHASE + BASE ASSEMBLY

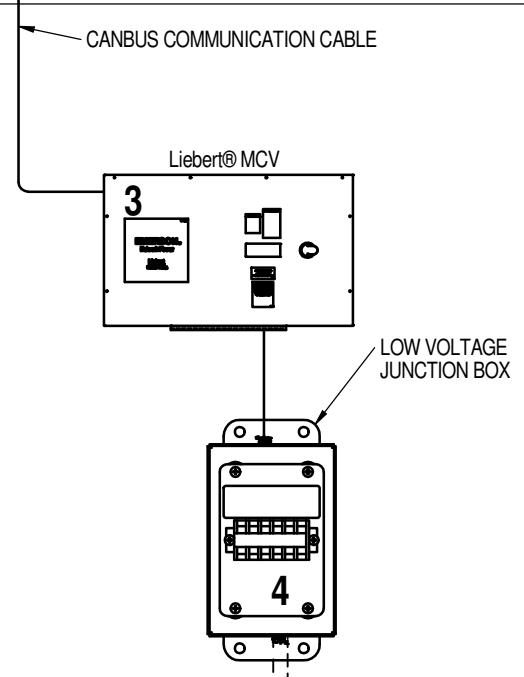
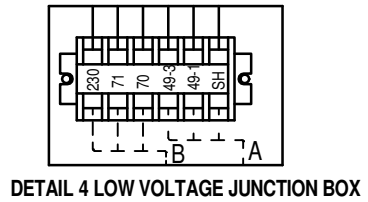
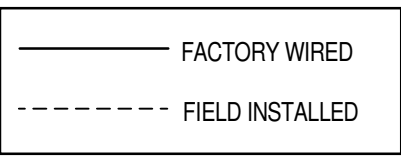
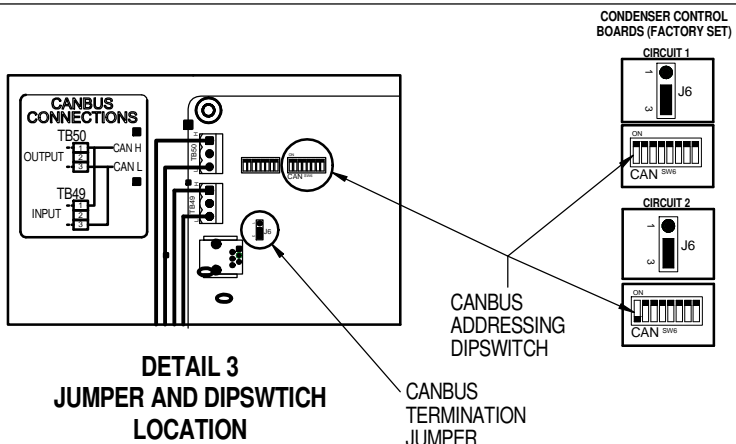
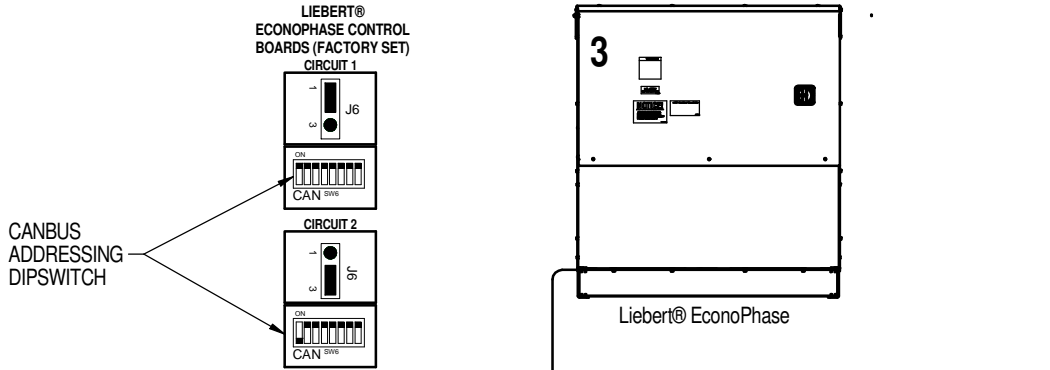

DETAIL 2 LIEBERT® HEAT REJECTION INTERLOCK

SEE SHEET 2 FOR
COMPONENT
NOTES, CABLE NOTES, &
WIRE NOTES

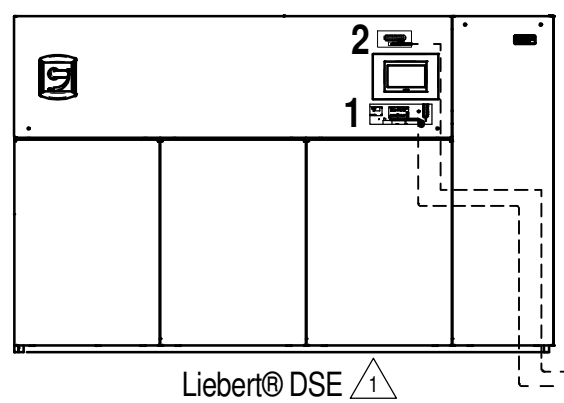
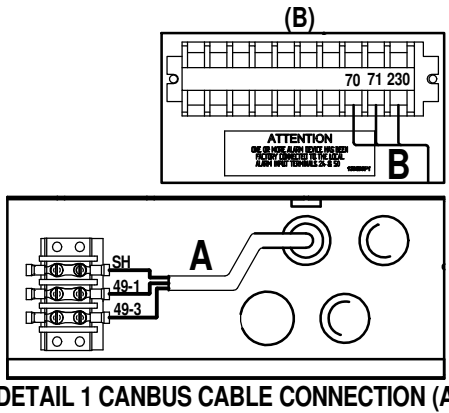

Note:
1. One (1) Liebert® DSE Unit shown for simplicity.



LIEBERT® HEAT REJECTION SKID

CANbus & INTERLOCK CONNECTIONS

LIEBERT® MCV + LIEBERT® ECONOPHASE + BASE ASSEMBLY

COMPONENT NOTES:

1. COMPONENT APPEARANCE, ORIENTATION, AND POSITION MAY VARY BETWEEN PRODUCT LINES. TERMINAL NAMES REMAIN CONSTANT.
2. ALL CIRCUITS TO THESE CONNECTION POINTS REMAIN CONSTANT.

CAN & CABLE NOTES (A):

1. CABLE MUST HAVE THE FOLLOWING SPECIFICATIONS:
 - BRAIDED SHIELD OR FOIL SHIELD WITH DRAIN WIRE
 - SHIELD MUST BE WIRED TO GROUND AT INDOOR UNIT
 - 22-18AWG STRANDED TINNED COPPER
 - TWISTED PAIR (MINIMUM 4 TWISTS PER FOOT)
 - LOW CAPACITANCE (15pF/FT OR LESS)
 - MUST BE RATED TO MEET LOCAL CODES AND CONDITIONS.
 - EXAMPLES BELDEN 89207 (PLENUM RATED), OR ALPHA WIRE 6454 CATEGORY 5, 5E, OR HIGHER.
2. DO NOT RUN IN SAME CONDUIT, RACEWAY, OR CHASE AS HIGH VOLTAGE WIRING.
3. FOR CANBUS NETWORK LENGTHS GREATER THAN 450FT(137M), CONTACT LIEBERT FACTORY.

INTERLOCK WIRE NOTES (B):

1. FIELD SUPPLIED WIRE
 - 3 CONDUCTOR 18AWG OR GREATER
 - RATED 600V
2. RUN FIELD SUPPLIED WIRES BETWEEN THE INDOOR UNIT AND THE LOW VOLTAGE JUNCTION BOX.

CANbus & INTERLOCK CONNECTIONS LIEBERT® MCV + LIEBERT® ECONOPHASE + BASE ASSEMBLY

ECONOPHASE CONTROL BOARDS (FACTORY SET)

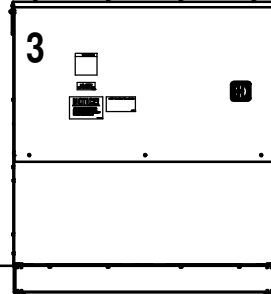
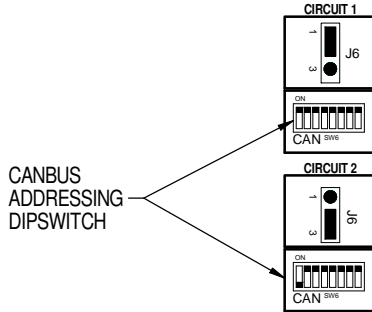

LIEBERT® ECONOPHASE UNIT

CONDENSER CONTROL BOARDS (FACTORY SET)

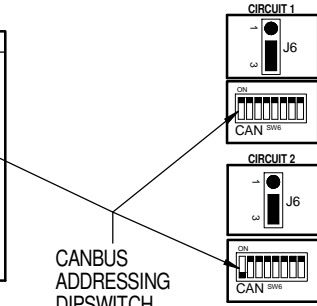

CANBUS COMMUNICATION CABLE

LIEBERT® MCV CONDENSER

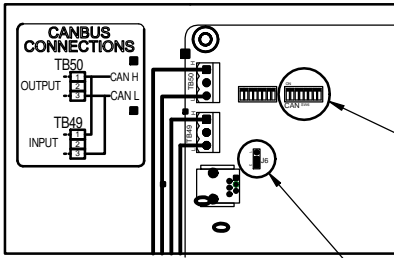

DETAIL 3
JUMPER AND DIPSWITCH LOCATION

CANBUS TERMINATION JUMPER

NOTE:
ONE Liebert® XDM system shown for simplicity.

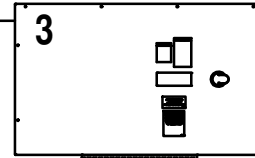

LOW VOLTAGE JUNCTION BOX

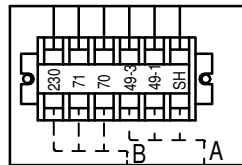
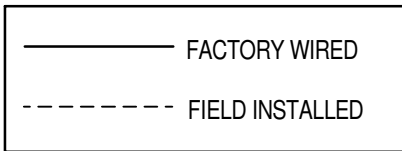

DETAIL 4 LOW VOLTAGE JUNCTION BOX

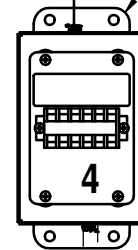

4

Partial Terminal Strip shown for clarity.

Terminal

Position

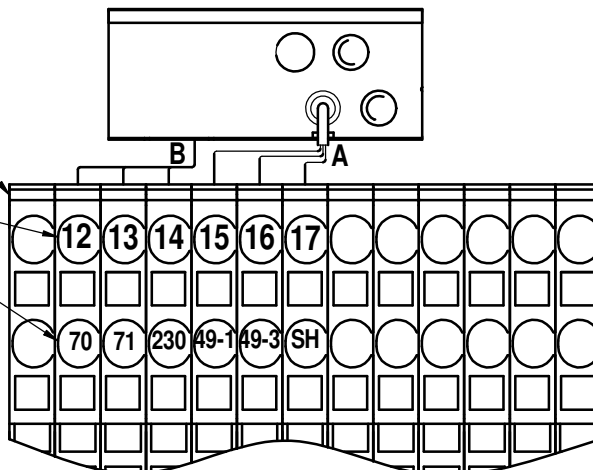

DETAIL 1 CANBUS CABLE CONNECTION (A)

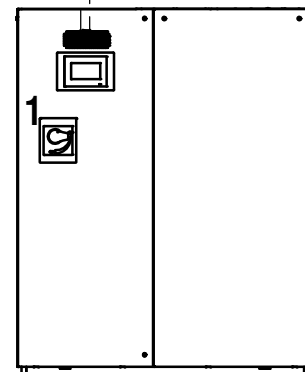

INDOOR LIEBERT® XDM UNIT

SEE SHEET 2 FOR
COMPONENT
NOTES, CABLE NOTES, &
WIRE NOTES



LIEBERT® XDM

CANbus & INTERLOCK CONNECTIONS

LIEBERT® MCV + LIEBERT® ECONOPHASE + BASE ASSEMBLY

COMPONENT NOTES:

1. COMPONENT APPEARANCE, ORIENTATION, AND POSITION MAY VARY BETWEEN PRODUCT LINES. TERMINAL NAMES REMAIN CONSTANT.
2. ALL CIRCUITS TO THESE CONNECTION POINTS REMAIN CONSTANT.

CAN & CABLE NOTES (A):

1. CABLE MUST HAVE THE FOLLOWING SPECIFICATIONS:
 - BRAIDED SHIELD OR FOIL SHIELD WITH DRAIN WIRE
 - SHIELD MUST BE WIRED TO GROUND AT INDOOR UNIT
 - 22-18AWG STRANDED TINNED COPPER
 - TWISTED PAIR (MINIMUM 4 TWISTS PER FOOT)
 - LOW CAPACITANCE (15pF/FT OR LESS)
 - MUST BE RATED TO MEET LOCAL CODES AND CONDITIONS.
 - EXAMPLES BELDEN 89207 (PLENUM RATED), OR ALPHA WIRE 6454 CATEGORY 5, 5E, OR HIGHER.
2. DO NOT RUN IN SAME CONDUIT, RACEWAY, OR CHASE AS HIGH VOLTAGE WIRING.
3. FOR CANBUS NETWORK LENGTHS GREATER THAN 450FT(137M), CONTACT LIEBERT FACTORY.

INTERLOCK WIRE NOTES (B):

1. FIELD SUPPLIED WIRE
 - 3 CONDUCTOR 18AWG OR GREATER
 - RATED 600V
2. RUN FIELD SUPPLIED WIRES BETWEEN THE INDOOR UNIT AND THE LOW VOLTAGE JUNCTION BOX.

Connect with Vertiv on Social Media



<https://www.facebook.com/vertiv/>



<https://www.instagram.com/vertiv/>



<https://www.linkedin.com/company/vertiv/>



<https://www.twitter.com/Vertiv/>



Vertiv.com | Vertiv Headquarters, 1050 Dearborn Drive, Columbus, OH, 43085, USA

© 2022 Vertiv Group Corp. All rights reserved. Vertiv™ and the Vertiv logo are trademarks or registered trademarks of Vertiv Group Corp. All other names and logos referred to are trade names, trademarks or registered trademarks of their respective owners. While every precaution has been taken to ensure accuracy and completeness here, Vertiv Group Corp. assumes no responsibility, and disclaims all liability, for damages resulting from use of this information or for any errors or omissions. Specifications, rebates and other promotional offers are subject to change at Vertiv's sole discretion upon notice