



# Liebert<sup>®</sup> EXL S1

## Installer Guide

250 kVA – 1200 kVA, 60 Hz, Three-phase UPS, Single-module and  
Multi-module (Distributed Bypass)

The information contained in this document is subject to change without notice and may not be suitable for all applications. While every precaution has been taken to ensure the accuracy and completeness of this document, Vertiv assumes no responsibility and disclaims all liability for damages result from use of this information or for any errors or omissions.

Refer to local regulations and building codes relating to the application, installation, and operation of this product. The consulting engineer, installer, and/or end user is responsible for compliance with all applicable laws and regulations relation to the application, installation, and operation of this product.

The products covered by this instruction manual are manufactured and/or sold by Vertiv. This document is the property of Vertiv and contains confidential and proprietary information owned by Vertiv. Any copying, use, or disclosure of it without the written permission of Vertiv is strictly prohibited.

Names of companies and products are trademarks or registered trademarks of the respective companies. Any questions regarding usage of trademark names should be directed to the original manufacturer.

### **Technical Support Site**

If you encounter any installation or operational issues with your product, check the pertinent section of this manual to see if the issue can be resolved by following outlined procedures.

Visit <https://www.vertiv.com/en-us/support/> for additional assistance.

# TABLE OF CONTENTS

<b>1 Important Safety Instructions</b> .....	<b>1</b>
<b>2 Mechanical Installation</b> .....	<b>3</b>
2.1 Pre-Installation Planning .....	3
2.2 Preliminary Checks .....	3
2.3 Environmental Considerations .....	3
2.3.1 UPS Room .....	3
2.3.2 Storing the UPS and Batteries for Delayed Installation .....	5
2.3.3 Installation Altitude .....	6
2.4 Positioning .....	6
2.4.1 Moving the Cabinets .....	6
2.4.2 Clearances .....	7
2.4.3 Raised-Floor Installations .....	7
2.4.4 Floor Anchors—Optional .....	7
2.4.5 Kick Plate Installation—Standard .....	7
2.4.6 Special Considerations for 1+N Parallel Systems .....	7
2.4.7 Unpacking and Unloading the Cabinet from the Pallet .....	8
2.5 System Configuration .....	9
2.6 Power Cable Busbars .....	10
2.7 Attaching Input/Output Cabinets .....	13
2.7.1 Moving Input/Output Cabinets into Position .....	13
<b>3 UPS Electrical Installation</b> .....	<b>15</b>
3.1 External Protective Devices .....	15
3.2 Power Cables .....	15
3.3 Sizing the Input Breaker that Feeds the UPS .....	16
3.3.1 Single or Dual Input Feeds .....	16
3.3.2 Automatic Transfer Switches .....	16
3.4 Input Power Cable Connection .....	16
3.4.1 Equipment Ground .....	17
3.5 DC Power Connections .....	18
3.6 Configuring Ground Connections .....	19
3.6.1 Three-Wire Input Connections .....	20
3.6.2 Recommended Grounding Configuration, Battery Systems .....	21
3.6.3 High-Resistance Ground Systems .....	22
3.7 Distributed Static Switch (1+N) System Cabling Layouts .....	22
3.8 Control Cable and Communication .....	23
3.8.1 Slots for Vertiv™ Liebert® IntelliSlot™ Cards—SLOT1 and SLOT3 .....	25
3.8.2 Slot for Vertiv™ Liebert® LIFE Services Products—SLOT2 .....	25
3.8.3 Serial Interface for Liebert LIFE Services Cards (Serial Input/Output)—XP6 .....	25
3.8.4 Connector for REPO (Input and Status)—AP30-XP10 .....	26
3.8.5 Customizable Output Dry Contacts—AP30/AP202 XP12 .....	26

3.8.6 Customizable Input Dry Contacts—AP30/AP202 XP11 .....	29
3.8.7 Connector for Parallel UPS Connection—AP30-XP71A, 71B, AP30-XP72A, 72B .....	31
3.8.8 RJ-45 Interface for Synchronization with External Signal—AP30-XP31 .....	32
3.8.9 UPS Control Contacts with Battery Cabinet or Module Battery Disconnect .....	32
3.8.10 UPS Control Contacts with Global Maintenance Bypass .....	32
3.9 Top Entry Low-Voltage .....	33
3.10 Bottom Entry Low-Voltage .....	33
<b>4 Optional Equipment .....</b>	<b>35</b>
4.1 Options .....	35
4.2 Rectifier Feed Breaker (RFB) .....	36
4.2.1 Remote Back-Feed Breaker .....	36
4.3 Multi-Module System Options and Accessories .....	37
4.3.1 Paralleling Cable Kit .....	38
4.3.2 Multi-Bus Synch Module (MBSM) .....	38
<b>5 Specifications .....</b>	<b>39</b>
<b>Appendices .....</b>	<b>55</b>
Appendix A: Technical Illustrations .....	55

# 1 Important Safety Instructions

## SAVE THESE INSTRUCTIONS

This manual contains important instructions that should be followed during installation of your Vertiv™ Liebert® EXL S1 UPS. Read this manual thoroughly, paying special attention to the sections that apply to your installation, before working with the UPS. Retain this manual for use by installing personnel.



**WARNING!** Risk of electrical shock. Can cause personal injury or death. This UPS has several circuits that are energized with high DC as well as AC voltages. Check for voltage with both AC and DC voltmeters before working within the UPS. Check for voltage with both AC and DC voltmeters before making contact. Only properly trained and qualified personnel wearing appropriate safety headgear, gloves, shoes and glasses should be involved in installing the UPS or preparing the UPS for installation. When performing maintenance on any part of the equipment under power, service personnel and test equipment should be standing on rubber mats. In case of fire involving electrical equipment, use only carbon dioxide fire extinguishers or those approved for use in fighting electrical fires.



**WARNING!** Extreme caution is required when performing installation and maintenance. Special safety precautions are required for procedures involving handling, installation and maintenance of the UPS system. Observe all safety precautions in this manual before handling or installing the UPS system. Observe all precautions in the Operation and Maintenance Manual, SL-26090, before as well as during performance of all maintenance procedures. Observe all DC safety precautions before working on or near the DC system.



**WARNING!** Risk of heavy unit falling over. Improper handling can cause equipment damage, injury or death. Exercise extreme care when handling UPS cabinets to avoid equipment damage or injury to personnel. Locate the center of gravity symbols and determine the unit's weight before handling each cabinet. Test lift and balance the cabinets before transporting them. Maintain minimum tilt from vertical at all times. Slots at the base of the module cabinets are intended for forklift use. Base slots will support the unit only if the forks are completely beneath the unit. Read all of the following instructions before attempting to move, lift or remove packaging from the unit, or to prepare the unit for installation. The UPS module weighs up to 4667 lb. (2117 kg).



**WARNING!** Risk of electrical shock and fire. Can cause equipment damage, personal injury or death. Only normal safety precautions are necessary under typical operation and with all UPS doors closed. The area around the UPS system should be kept free of puddles of water, excess moisture and debris. Only test equipment that is designed for troubleshooting should be used. This is particularly true for oscilloscopes. Always check with an AC and DC voltmeter to ensure safety before making contact with the UPS or using tools to work on any UPS component. Dangerously high potential electric charges may exist at the capacitor banks and at the DC connections even when input power is turned Off. All wiring must be installed by a properly trained and qualified electrician. All power and control wiring must comply with all applicable national, state and local codes. One person should never work alone, even if all power is disconnected from the equipment. A second person should be standing nearby to assist and to summon help in case of an accident.

## NOTICE

This unit complies with the limits for a Class A digital device, pursuant to Part 15 Subpart J of FCC rules. These limits provide reasonable protection against harmful interference in a commercial environment. This unit generates uses and radiates radio frequency energy and, if not installed and used in accordance with this instruction manual, may cause harmful interference to radio communications. Operation of this unit in a residential area may cause harmful interference that the user must correct at his own expense.

**NOTE: Materials sold hereunder cannot be used in the patient vicinity (e.g., use where UL, cUL or IEC 60601-1 is required). Medical applications such as invasive procedures and electrical life support equipment are subject to additional terms and conditions.**

## 2 Mechanical Installation

### 2.1 Pre-Installation Planning

This section describes the requirements that must be taken into account when planning the positioning and cabling of the UPS and related equipment.

Installing personnel should observe these general procedures and practices. The particular conditions of each site will determine the applicability of such procedures.



**WARNING! Risk of electrical shock. Can cause injury or death. Special care must be taken when working with the batteries associated with this equipment. When the batteries are connected together, the battery-terminal voltage will exceed 400VDC and is potentially lethal.**

**NOTE: All equipment not referred to in this manual is shipped with details of its own mechanical and electrical installation.**

#### NOTICE

Risk of incorrect input power connection. Can cause equipment damage.

The standard Liebert® EXL S1 is suitable for connection to 60Hz, 3-phase, 3-wire-plus-ground input power.

**NOTE: Do not apply electrical power to the UPS equipment before the arrival of the commissioning engineer. Connecting power before the commissioning engineer determines the system is properly installed may void the warranty.**

### 2.2 Preliminary Checks

Before installing the UPS, carry out the following preliminary checks:

- Visually examine the UPS equipment for transit damage, both internally and externally. Report any damage to the shipper and to your Vertiv™ representative immediately.
- Verify that the correct equipment is being installed. The equipment supplied has an identification tag on the interior of the doors stating the type, size, and main-calibration parameters of the UPS.
- Verify that the UPS room satisfies the environmental conditions stipulated in the equipment specification, paying particular attention to the ambient temperature and air exchange system.

### 2.3 Environmental Considerations

#### 2.3.1 UPS Room

The UPS should be installed vertically, on a level and even concrete or other non-combustible surface, and in an area protected from extremes of temperature and humidity. Refer to [Specifications](#) on page 39 for detailed product specifications.

The EXL S1 is intended for indoor installation and should be located in a cool, dry, clean-air environment with adequate ventilation to keep the ambient temperature within the specified operating range (see [Table 5.3](#) on page 42).

**NOTE: Vertiv™ will not accept liability or pay costs, fees, or damages arising from storing or operating the UPS outside of the specified environmental, performance, or operating ranges and conditions as set forth herein or in other product documentation. Please contact Vertiv Technical Support for more information.**

The UPS is cooled with the aid of internal fans. Do not cover the ventilation openings. Cooling air must enter and exit the cabinets freely to prevent overheating or malfunctioning.

The UPS is equipped with air filters behind the front doors. A schedule for inspection of the air filters is required. The period between inspections will depend upon environmental conditions.

When using bottom-entry cabling, the conduit plate must be installed.

Keep all protective shrink wrap on the unit and remove it only when required. If the unit does not have an external, temporary filter (Grainger Part Number 2JTA8 or equivalent) installed on top of the unit (see **Figure 21** below) contact Vertiv Technical Support.

The UPS is shipped with external filter material that must remain attached to the UPS to protect potential areas of foreign debris ingress to the UPS. In addition to the external filter material, filters installed on the top and front of the UPS must not be removed during construction activities. All filter media is necessary to prevent debris and dust entry to the UPS throughout the installation process. The external temporary filter at the top of the UPS will be removed by a Vertiv Customer Engineer during startup and must be reinstalled whenever the UPS is not operating during construction activities.

**Figure 2.1 Liebert® EXL S1 with Temporary Filter Installed**

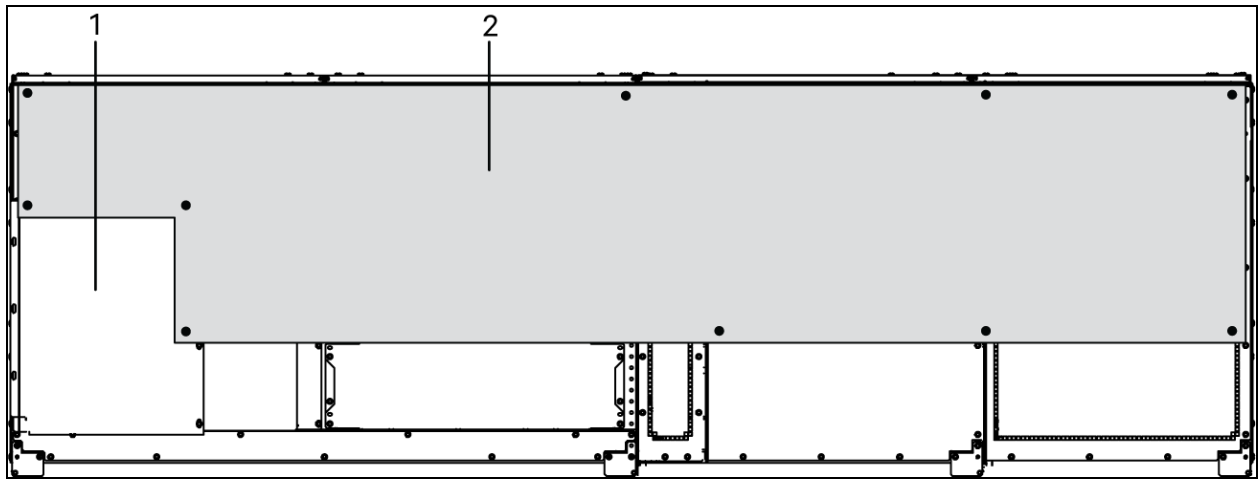

Item	Description
1	Top of UPS; 625-800kVA unit shown
2	Filter coverage area

**NOTICE**

Foreign material inside or in the vicinity of the UPS module presents a potential risk to the operational integrity of an installed UPS system.

This risk is especially high if any conductive material finds its way inside the UPS module.

The risk potentially involves damage to the installed UPS equipment and subsequent degradation or loss of power to the connected critical site load.

Vertiv™ applies the highest safety standards in equipment design to ensure that no live parts are exposed to external contact, and also to ensure that the equipment is protected against the introduction of foreign bodies during operation. However, it is not possible for Vertiv to ensure that foreign bodies will not be introduced during on-site installation, or when the UPS doors and covers are open and the electrical terminals are exposed to allow power line connections to be made by the electrical contractor/installer.



To prevent major disruption to site operations and risk to property and personnel, including the possibility of a fatality, each site's facility manager or construction manager must prevent foreign bodies from being introduced into the UPS module.

All UPS modules are thoroughly inspected by Vertiv engineers before being placed into service and testing on-site. However, the person responsible for the site must ensure that the UPS module and the immediate surroundings are kept clean and free from any possible conductive material such as metal foil, food wrappers, cable shields, washers and other hardware, scrap metal and dust.

If the UPS system is shut down after placement into service and testing is completed, the UPS room must be kept clean to avoid the possibility (during restart) of the considerable volume of airflow produced by UPS operation to dislodge and/or drag any foreign bodies into the equipment, which can result in system failure and possible supply interruption to the critical site load, and several hours of downtime resulting from the damage typically associated with such events.

If the UPS is left running/operational after placement into service and testing, the room must be kept clean to prevent foreign bodies from entering the UPS module via its forced-air flow.

**NOTE: Ensure that the top of the UPS is protected from any metal shavings and debris by using the temporary external filter material that shipped with the UPS. The installer is responsible for ensuring that no conductive material enters the unit. The installer will be billed at Vertiv's prevailing labor wage for any cleaning or unit or component failure as a result of debris entering the unit.**

### 2.3.2 Storing the UPS and Batteries for Delayed Installation

If the UPS system will not be installed immediately, store it indoors in a clean, dry and cool location (see **Table 5.3** on page 42 ). If the system includes a battery cabinet, the batteries' requirements dictate the storage conditions. Unpack, install, and charge batteries as soon as possible after delivery.

#### NOTICE

Risk of failure to properly charge the batteries. Can cause permanent damage to the batteries and void the warranty.

Batteries will discharge during storage. Batteries must be recharged as recommended by the battery manufacturer. A notice of "Charge Before Date" is affixed to each cabinet that has batteries inside. The "Charge Before Date" is calculated based on storing the batteries at 77°F (25°C). Storage at a higher temperature will increase the rate of self-discharge, which requires earlier recharging. Consult the battery manufacturer on how to determine when the batteries need to be recharged.

## 2.3.3 Installation Altitude

The maximum operating altitude of the UPS, without derating, is 3300 ft (1000 m). At higher altitudes the load must be reduced according to **Table 2.1** below.

**Table 2.1 Altitude derating**

Altitude, ft. (m)	Derating Factor
3281 (1000)	1.000
3937 (1200)	0.990
4922 (1500)	0.975
6566 (2000)	0.950
8203 (2500)	0.925
9843 (3000)	0.900
11,483 (3500)	0.875
11,811 (3600)	0.870
13,124 (4000)	0.850
13,780 (4200)	0.840
14,764 (4500)	0.825
16,405 (5000)	0.800

## 2.4 Positioning

The cabinet is structurally designed to permit lifting from the base with a forklift, pallet jack or similar equipment.

Access to the power terminals, auxiliary terminal blocks and power switches is from the front and top.

The doors and top low-voltage cover can be opened for access to the power connection bars, auxiliary terminal blocks and power isolators. The front door can be opened 90 degrees for more flexibility in installations.

### 2.4.1 Moving the Cabinets

Plan the travel route between the point of arrival and the unit's position to make sure that all passages are wide enough for the unit and that floors are capable of supporting its weight. For instance, check that doorways, lifts, ramps and so on are adequate and that there are no impassable corners or changes in the level of corridors that would prevent passage.

Ensure that the UPS weight is within the designated surface weight loading ( $\text{kg}/\text{cm}^2$ ) of any handling equipment. For weight details, see **Table 5.2** on page 41.

Move the UPS with a forklift or similar equipment to ease the relocation and to reduce unit vibration. The bottom structure of the UPS will support the unit only if the forks are completely beneath the unit. The optional battery cabinets also should be moved with a forklift or similar equipment.

Ensure that any equipment used in moving the UPS cabinet has sufficient lifting capacity to transport the unit. Care must be taken to protect the panels. Do not tilt the UPS or other system cabinet more than 15 degrees.

Handling with straps is not authorized.



**WARNING! Risk of heavy unit falling over. Improper handling can cause equipment damage, injury or death. Because the weight distribution in the cabinet is uneven, use extreme care while handling and transporting. Take extreme care when handling UPS cabinets to avoid equipment damage or injury to personnel. Locate the center of gravity symbols and determine the unit's weight before handling each cabinet. Test lift and balance the cabinets before transporting them. Maintain the minimum tilt from vertical at all times. The UPS module weighs up to 4667 lb. (2117kg).**

## 2.4.2 Clearances

The UPS has no ventilation grilles at either side or at the rear. Leave a distance of 24 in. (610 mm) between the top of the UPS and any overhead obstacles for service and adequate circulation of air from the unit. Clearance around the front of the equipment should be sufficient to enable free passage of personnel with the doors fully opened, about 50 in. (127cm). In the rare instance of module replacement, 50 in. (127cm) of clearance is required for the Service team to perform module replacement. 50 in. (127 cm) allows adequate clearance for both the module and the heavy duty lift used by the Service team to remove and replace the modules. If 50 in. (127cm) is not available, then the Service team will instead replace components and subassemblies in the modules as part of their repair process.

## 2.4.3 Raised-Floor Installations

If the equipment will be installed on a raised floor, mount the UPS on a pedestal suitably designed to accept the equipment point-loading. Refer to the base view to design this pedestal.

## 2.4.4 Floor Anchors—Optional

For seismic-resistant installations, special floor anchors must be used for the UPS and matching battery cabinets; see [Specifications](#) on page 39.

## 2.4.5 Kick Plate Installation—Standard

Kick plates must be installed. If the unit will be installed in a position that does not permit access to rear of the UPS, install the kick plates before the unit is placed in its final position.

## 2.4.6 Special Considerations for 1+N Parallel Systems

Consider the grounding configuration of your system before finalizing module placement; see [Configuring Ground Connections](#) on page 19.

The cabling impedance must be closely matched to ensure proper load-sharing. Mismatched impedance may cause an overload on one module in a 1+N system, triggering a shutdown and loss of power to the connected load. Mismatched cable impedance is amplified when a 1+N system is operating on bypass because the power on the bypass path is not controlled. We recommend matching the impedance in the bypass path of paralleled systems as closely as possible to ensure good bypass current sharing.

The 1+N UPS Bypass Current Sharing Inductor option can be used to minimize the effects of cable impedance mismatch.

The impedance mismatch can also be minimized by controlling the wiring length of each unit. The design and the layout of the UPS system and associated panels and cabling should be examined closely to ensure that cable lengths and impedance are closely matched.

For Liebert® EXL S1 systems, the total combined cable length of the bypass feeder cables and the module output cables for each module must be within 5% from maximum to minimum. The combined cable length is the sum of the length from the common source feeding all the modules to the common output switchboard.

If the cabling impedance must be greater than 5% or the total, planned system load exceeds more than 85% per module, contact your Vertiv™ representative to calculate whether the system will result in an overload condition when operating on bypass.

When bringing a 1+N system on line for the first time or after removing one unit, we recommend checking the bypass current mismatch. To check the bypass current mismatch:

1. Place a load on the bypass of each UPS module.
2. View the output current of each unit.

The accuracy of the currents displayed on the UPS module is sufficient for this check. If the mismatch is greater than 5%, the bypass impedance must be balanced or the load must be limited to less than the maximum rating.

The output switchboard for any 1+N system must be configured with one Module Output Circuit Breaker (MOB) for each UPS module that is to be connected to that switchboard. The breaker must be equipped with auxiliary contacts that will be monitored by the UPS in order for interlocks to function properly and for the HMI to indicate the bypassed status of the module.

We recommend selecting breakers that work with current levels that may occur when switching a module onto the active bus. Breakers with adjustable instantaneous settings should be adequate to achieve this.

For further information about matching cable impedance or refer to Performance Improvements with Sharing Inductors in Distributed Static Switch UPS Systems on the EXL S1 product page at [www.Vertiv.com](http://www.Vertiv.com), or contact Vertiv support, <http://www.Vertiv.com/support/>.

## 2.4.7 Unpacking and Unloading the Cabinet from the Pallet

Take the utmost care when removing the packaging to prevent damage to the equipment. Check all packaging materials to ensure that no important items are discarded.

Once the packaging is removed, take the UPS off the pallet by removing the retaining screws securing it to the pallet. Refer to page 5 of the appropriate illustration included in [Technical Illustrations](#) on page 55. **2.5** on the facing page, lists the relevant drawings by number.

Once the retaining screws are removed from the pallet, lift the unit off with a forklift.

Do not remove the retaining brackets from the UPS because they are used to fasten the UPS to the floor, except where seismic compliance is required and the optional seismic anchoring kits are used.

## 2.5 System Configuration

A UPS system is composed of a number of equipment cabinets, depending on the individual system design requirements. In general, all the cabinets in an installation will be the same height.

**NOTE: If you are bolting cabinets together, remove the side panels before beginning installation.**

- **UPS with connected battery cabinets**—Shown in **Figure 22** below. The battery cabinets are connected to the UPS and internally wired. The battery cabinets must be installed on the right of the UPS in a connected system. On 600kVA and lower models, the battery wiring cabinet is a separate cabinet installed on the right side of the UPS between the UPS and battery cabinets.
- **Stand-alone, interconnected battery cabinets**—Shown in **Figure 23** on the next page, with the battery junction cabinet on one end. The battery cabinets are interconnected with the battery wiring cabinet, but are not connected to the right side of the UPS. In this configuration, the battery junction cabinet may be on either end or between the battery cabinets.
- **Stand-alone battery system**—The battery cabinet system stands alone. In this configuration, there is no junction cabinet and the battery cabinets are not connected to the UPS. Battery power cables are routed directly to the DC busbars in the UPS I/O cabinet.

**NOTE: Make sure that you complete all of the connections detailed in the “Interconnection Details” drawing before making any power-cabling connections. The interconnects are very hard to access after the power wiring is complete. See [Technical Illustrations](#) on page 55, for the appropriate drawing for your system**

The detailed arrangement and cabinet dimensions for your UPS system is described in the installation drawings. Refer to the appropriate illustrations for your unit included in [Technical Illustrations](#) on page 55.

**Figure 2.2 Connected and Internally Wired UPS System**

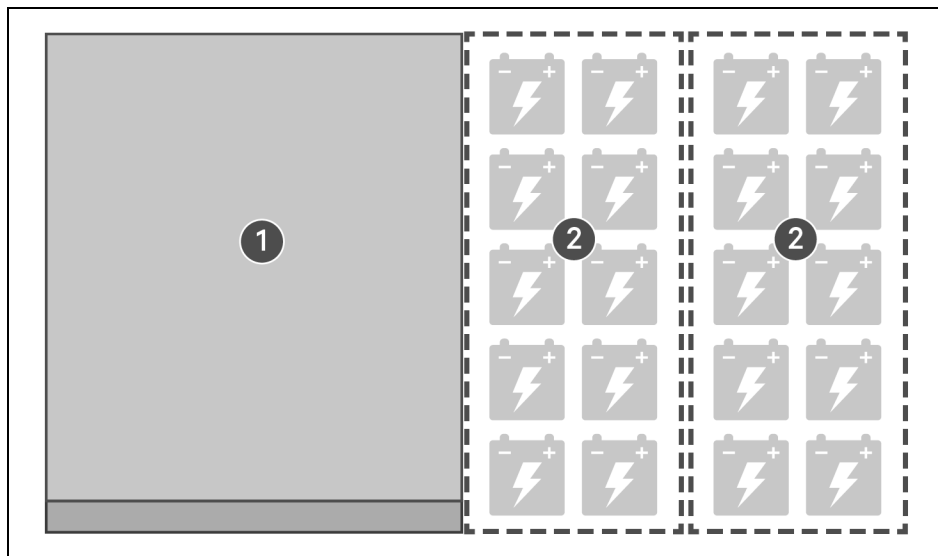

Item	Description
1	UPS
2	Battery cabinets

**Figure 2.3 Stand-Alone, Interconnected Battery Cabinets**

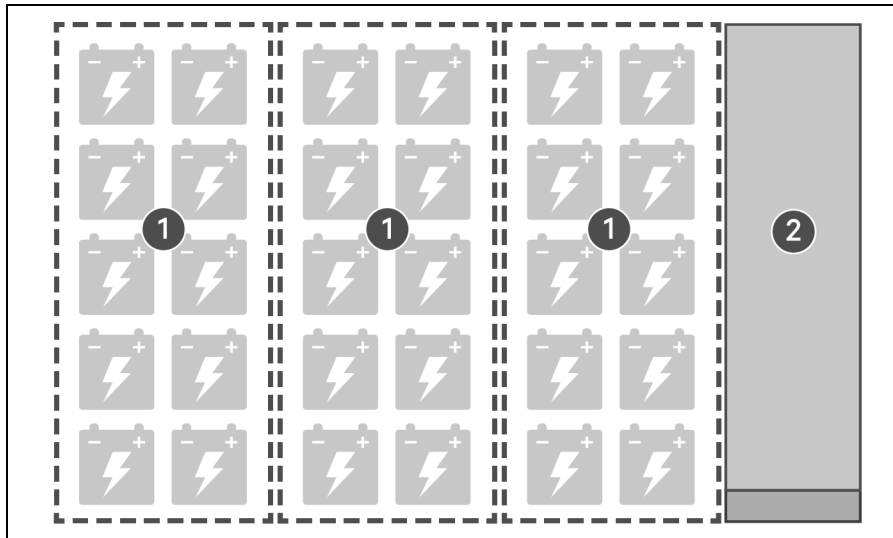

Item	Description
1	Battery cabinet
2	Junction cabinet

## 2.6 Power Cable Busbars

Cables can enter the UPS cabinet from bottom or top into the input/output (I/O) section of the unit. Various battery cabinet arrangements are illustrated in [System Configuration](#) on the previous page

The detailed cabling and connection for your UPS system is described in the installation drawings. In addition to the following instructions, refer to the appropriate illustrations for your unit included in [Technical Illustrations](#) on page 55 .

Input power, from utility power or from a DC system, connects to the UPS through an input/output cabinet. When Liebert® battery cabinets are attached to the UPS, Vertiv™ supplies the busbars and cables for the power connections.

- A UPS with static bypass utilizes only Input/Output Cabinet 1.
- A UPS with **back-feed disconnect, common mode choke, bypass sharing inductors** or any combination of these options, utilizes Input/Output Cabinet 2 or Input/Output Cabinet 3.

The battery cabinets connect to the input/output cabinet with busbars.

- UPS models with static bypass only employ busbars that enter below the cabinet roof line. Those busbars are enclosed by the battery cabinet and the input/output cabinet.
- UPS models with back-feed disconnect, common mode choke, bypass sharing inductors or with any combination of these options, employ busbars that extend through openings in the tops of the adjacent battery cabinet and input/output cabinet. These busbars require a protective, factory-supplied shroud that is attached to the input/output cabinet and the adjacent attached battery cabinet. The protective, factory-supplied shroud is shown in **Figure 2.5** on page 12 .

### To connect power to the UPS from the attached battery system:

1. Remove the panels from the right side of the input/output cabinet and from the left side of the adjacent battery cabinet.
2. Position the cabinets and bolt them together.

3. Remove two interconnect straps and the M10 mounting hardware from the battery cabinet. Keep straps and hardware for possible future use.
4. Use the hardware supplied in the cable kit to connect the output busbars from the battery cabinet to the input busbars in the input/output cabinet.

**NOTE: Busbar connections vary depending on the system rating. For details, refer to the submittal drawings that shipped with the battery system and to **Figure 2.4** below and **Figure 2.5** on the next page .)**

5. Torque the busbar and cable connectors to 480 in-lb. (54Nm).
6. **On systems connecting to Input/Output Cabinet 2 or 3, install the protective shroud using the four factory-supplied M6 x 12mm self-tapping screws to attach the shroud and enclose the busbars, see **Figure 2.5** on the next page .**

**Figure 2.4 Battery Cabinet Busbar Connections to Input/Output Cabinet 1**

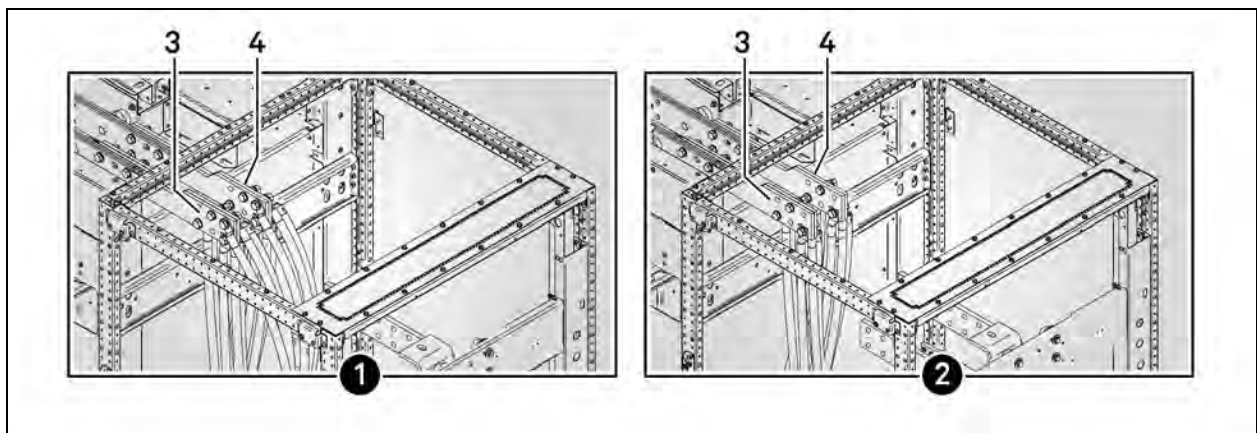

Item	Description
1	1000kVA to 1200kVA models
2	500kVA to 800kVA models
3	Connect to negative battery bus in I/O cabinet
4	Connect to positive battery bus in I/O cabinet

Figure 2.5 Battery Cabinet Busbar Connections to Input/Output Cabinet 2 or 3 (1200kVA model shown)

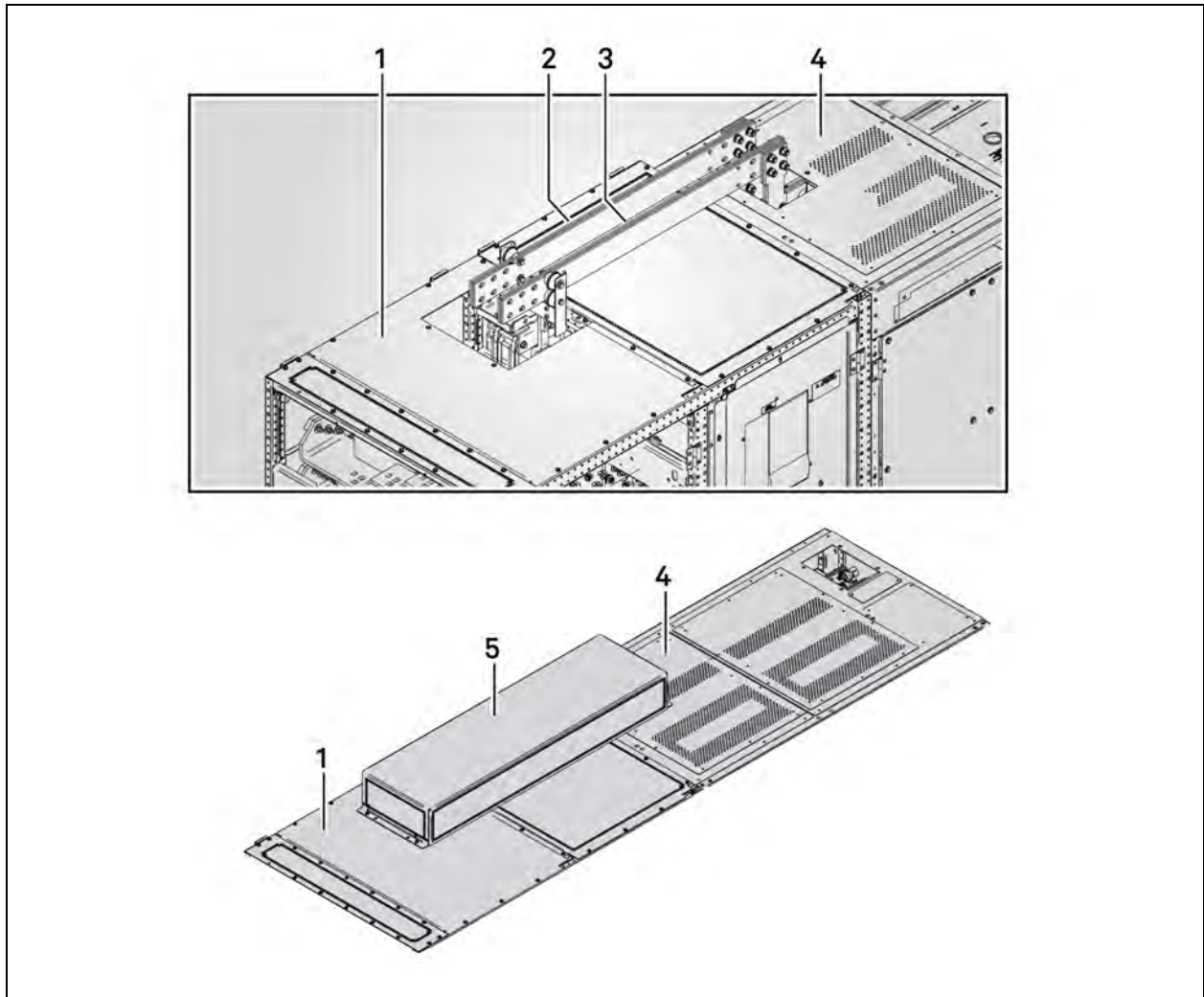

Item	Description
1	Input/output cabinet
2	Busbar x 3
3	Busbar x 3
4	Battery cabinet
5	Busbar shroud



## 2.7 Attaching Input/Output Cabinets

The UPS utilizes input/output cabinets for electrical connections.

A UPS with static bypass only utilizes Input/Output Cabinet 1.

A UPS with the optional back-feed disconnect, the optional common mode choke, the optional bypass sharing inductors or with any combination of those options utilizes Input/Output Cabinet 2 or 3.

The connection points and shipping splits for your UPS system are described in the installation drawings. Refer to the appropriate illustrations for your unit included in [Technical Illustrations](#) on page 55 .

The following table lists relevant drawings by number, UPS model and options.

**Table 2.2 Connection and Shipping-Split Drawings**

Drawing Number	model/options
559322P1	Mechanical installation, 800 and 1200kVA UPS with Input/Output Cabinet 1
561763P1	Mechanical installation, 800 and 1200kVA UPS with Input/Output Cabinet 2 or 3

### 2.7.1 Moving Input/Output Cabinets into Position

An input/output cabinet must be moved toward the UPS cabinet from the end. Damage may occur if it is moved straight back along the shipping split.

**Before moving an input/output cabinet into position**, three input fuses must be removed. For the location, refer to the appropriate illustrations for your unit included in [Technical Illustrations](#) on page 55 . **Table 2.2** above lists relevant drawings by number, UPS model and options.

This page intentionally left blank

## 3 UPS Electrical Installation

These guidelines are for qualified installers who must have knowledge of local wiring practices pertaining to the equipment to be installed.



**WARNING! Risk of electrical shock. Can cause injury or death. The UPS contains high DC as well as AC voltages. Check for voltage with both DC and AC voltmeters before working within the UPS. Only properly trained and qualified personnel wearing appropriate safety headgear, gloves, shoes and glasses should be involved in installing the UPS or preparing the UPS for installation.**

### 3.1 External Protective Devices

For safety, it is necessary to install circuit breakers in the input AC supply and external battery system. Given that every installation has its own characteristics, this section provides guidelines for qualified installation personnel with knowledge of operating practices, regulatory standards and the equipment to be installed.

External overcurrent protection must be provided. See **5** on page 39 for overload capacity.

### 3.2 Power Cables

The UPS requires both power and control cabling. All control cables, whether shielded or not, should be run separately from the power cables in metal conduits or metal ducts that are electrically bonded to the metalwork of the cabinets to which they are connected.

The cable design must comply with the voltages and currents in **5** on page 39, through **5** on page 39, follow local wiring practices and take into consideration the environmental conditions (temperature and physical support media), room temperature and conditions of installation of the cable and system's overload capacity (see [Specifications](#) on page 39).



**WARNING! Risk of electrical shock. Can cause injury or death. Before cabling the UPS, ensure that you are aware of the location and operation of the external isolators that connect the UPS input/bypass supply to the power distribution panel. Check that these supplies are electrically isolated and post any necessary warning signs to prevent them from being connected to the UPS or other system cabinets.**

Risque de décharge électrique pouvant causer des blessures graves, voire mortelles. Avant de procéder au câblage du système ASC, assurez-vous que vous êtes au courant de l'emplacement et du fonctionnement des isolateurs externes qui raccordent l'alimentation d'entrée ou de dérivation au panneau de distribution électrique. Vérifiez que ces raccords sont isolés électriquement et installez tous les panneaux d'avertissement nécessaires pour empêcher leur utilisation accidentelle.

When sizing battery cables, a maximum volt drop of 2VDC is permissible at the current ratings given in **5** on page 39.

The following are guidelines only and are superseded by local regulations and codes of practice where applicable:

- The grounding conductor should be sized according to the fault rating, cable lengths, type of protection, etc. The grounding cable connecting the UPS to the main ground system must follow the most direct route possible.
- Using smaller, paralleled cables for heavy currents can ease installation.
- AC and DC cables must be run in conduits according to local codes, national codes and standard best practices. This will prevent creation of excess EMI fields.

## 3.3 Sizing the Input Breaker that Feeds the UPS

Nominal input current (considered continuous) is based on full-rated output load. Maximum current includes nominal input current and maximum battery recharge current (considered noncontinuous).

Continuous and noncontinuous current are defined in the NEC.

Maximum input current is controlled by the current limit setting, which is adjustable. Values shown are for maximum current limit. If a smaller input feed breaker is used, the input current limit can be adjusted; see your Vertiv™ representative for more information. The input current limit should not be set less than 105% of the current needed to support the inverter at full load for normal operation.

This results in sufficient power to recharge the battery in a reasonable time and to operate over the published input voltage range.

### 3.3.1 Single or Dual Input Feeds

The UPS may be fed from single reference sources or dual asynchronous sources with optional common-mode choke. If a single-input configuration will be used, the utility source must be cabled to the rectifier input busbars.

**NOTE: Make sure that you complete all of the connections detailed in the “Interconnection Details” drawing before making any power cabling connections. The interconnects are very hard to access after the power wiring is complete. See [Technical Illustrations](#) on page 55, for the appropriate drawing for your system**

The terminal details and connections for your UPS system are described in the installation drawings. Refer to the appropriate illustrations for your unit included in [Technical Illustrations](#) on page 55.

### 3.3.2 Automatic Transfer Switches

If the UPS is fed from an automatic transfer switch, the UPS can transfer to and from an alternate out-of-phase source in double-conversion mode without applying a break-before-make delay to the automatic transfer switch operation.

## 3.4 Input Power Cable Connection

The rectifier input, bypass, output and battery power cables (all require lug-type terminations) are connected to busbars in the I/O sections. The terminal details and connections for your UPS system are described in the installation drawings. Refer to the appropriate illustrations for your unit included in [Technical Illustrations](#) on page 55.

**NOTE: Before making any power-wiring connections, make sure that you complete all of the interconnections for your system. The interconnects are very hard to access after the power wiring is complete. To make the interconnections, see connections the appropriate “Interconnection Details” drawing for your system, listed in [2.5](#) on page 9.**

### 3.4.1 Equipment Ground

The equipment ground busbar is in the I/O section, described in the appropriate illustrations for your unit, included in [Technical Illustrations](#) on page 55 .

The grounding conductor must be connected to the ground busbar and bonded to each cabinet in the system.

All cabinets and cabling must be grounded in accordance with local regulations.

**NOTE: In addition to safety requirements, it is important to follow grounding best practices for EMC requirements. For example, daisy-chain grounding connection between UPS modules located in different electrical rooms or floors is not recommended. Proper grounding reduces problems in systems caused by electromagnetic interference.**



**WARNING! Failure to follow adequate grounding procedures can result in electric shock hazard to personnel and the risk of fire, should a ground fault occur. All operations described in this section must be performed by properly trained and qualified electricians or technical personnel. If any difficulties are encountered, contact Vertiv™ Technical Support, <http://www.Vertiv.com/support/>.**

Le non-respect des procédures de mise à la terre peut entraîner des risques d'électrocution du personnel et des risques d'incendie en cas de défectuosité de la mise à la terre. Toutes les opérations décrites dans cette section ne doivent être effectuées que par des électriciens ou des techniciens professionnels dûment formés et qualifiés . En cas de difficultés, communiquez avec Vertiv™. Pour obtenir les renseignements de contact, consultez la dernière page de ce manuel.

Once the equipment has been positioned and secured, connect the power cables. Refer to the appropriate illustrations for your unit, included in [Technical Illustrations](#) on page 55 , and complete the following steps:

1. Verify that the UPS equipment is isolated from its external power source and that all the UPS power isolators are Open.
2. Check that these supplies are electrically isolated and post any necessary warning signs to prevent their inadvertent operation.
3. Open exterior and interior panels on the front of the I/O sections.
4. Connect the ground to the equipment ground busbar in the I/O sections.
5. Make power connections and tighten the connections to the proper torque.
6. Ensure correct phase rotation.



**WARNING! Risk of electrical shock. Can cause injury or death. If the load equipment will not be ready to accept power on the arrival of the commissioning engineer, ensure that the system output cables are safely isolated at their termination.**

Risque de décharge électrique pouvant causer des blessures graves, voire mortelles. Si les équipements branchés ne sont pas prêts à être alimentés à l'arrivée de l'ingénieur de mise en service, assurez-vous que les bornes des câbles de sortie du système soient isolées de façon sécuritaire.



**WARNING! Risk of electrical shock. Can cause injury or death. When connecting the cables between the battery extremities to the circuit breaker, always connect the circuit breaker end of the cable first.**

Risque de décharge électrique pouvant causer des blessures graves, voire mortelles. Lors du raccordement de câbles entre des bornes de batterie et un disjoncteur, branchez toujours en premier l'extrémité du câble qui se raccorde au disjoncteur.

7. For control connection details, see [Control Cable and Communication](#) on page 23 .
8. Close and secure the interior and exterior doors.
9. Attach the kick plates to the bottom of the unit.

**NOTE: If the unit is to be installed in a position that does not permit access to the rear kick plates, then the kick plates must be installed before the unit is placed in its final position.**

## 3.5 DC Power Connections



**WARNING! Risk of electrical shock. Can cause injury or death. The UPS contains high DC as well as AC voltages. Check for voltage with both DC and AC voltmeters before working within the UPS, the input/output cabinet or the battery cabinet. Only properly trained and qualified personnel wearing appropriate safety headgear, gloves, shoes and glasses should be involved in installing the UPS or preparing the UPS for installation.**

Vertiv™ recommends installing a local battery disconnect near the battery for safe maintenance. If this is not possible, it is required to use a lock-out tag-out device in the battery room and always check for hazardous voltage before performing maintenance on the UPS.

An external battery protection device must be installed to ensure adequate protection in case of short circuit fault. This protection may consist of fuses or automatic breakers suitable for DC applications. Size the external battery protection device in accordance with the available battery short circuit current and the battery string voltage.

### Notice

Batteries are able to withstand an external short circuit under specific conditions and for a specified duration. Fuses, circuit breakers and cables must be selected in accordance to the battery characteristics. Contact Vertiv Technical Support for more information.

### Notice

External shorts can lead to irreversible battery damage and reduced battery service life.



**WARNING! Missing or incorrect battery protection may cause extensive damage to the batteries, the UPS and ancillary equipment. Vertiv will neither accept liability nor pay damages resulting from accidents caused by missing or incorrect sizing of the battery protection device(s). Contact Vertiv Technical Support for more information.**

Vertiv recommends using a proprietary battery breaker control option to remotely trip the battery breaker and safely disconnect the battery when an undervoltage condition is detected. Contact Vertiv Technical Support for more information.

Liebert® battery cabinets installed attached to the EXL S1 are connected to the input/output cabinet with busbars. UPS models with the static bypass only employ busbars that are contained by the battery cabinet and the input/output cabinet.

**NOTE: Before making any power wiring connections, make sure that you complete all of the interconnections for your system. The interconnects are very hard to access after the power wiring is complete. To make the interconnections, see connections the appropriate “Interconnection Details” drawing for your system, listed in 2.5 on page 9 .**

UPS models with the back-feed disconnect, common mode choke or bypass sharing inductors or with any combination of these options employ busbars that extend through openings in the tops of the adjacent battery cabinet and input/output cabinet. These busbars require a protective, factory-supplied shroud that is attached to the input/output cabinet and the adjacent, attached battery cabinet.

When Liebert battery cabinets are attached to the UPS, the busbars and cables for the power connections are factory-supplied.

**To connect power cables for a battery system attached to the EXL S1:**

1. Remove the panels from the right side of the input/output cabinet and from the left side of the adjacent Liebert battery cabinet.
2. Position the cabinets and bolt them together.
3. Remove two interconnect straps and the M10 mounting hardware from the battery cabinet. Keep the straps and hardware for possible future use.
4. Use the hardware supplied in the cable kit to connect the output busbars from the battery cabinet to the input busbars in the input/output cabinet.

**NOTE: Busbar connections vary depending on the system rating. For details, refer to the submittal drawings that shipped with the battery system and to the battery system manual that shipped with the battery system.**

5. Torque the busbar and cable connectors to 480 in-lb. (54Nm).
6. **On systems with the common mode choke, with bypass sharing inductors or with both options**, use the four factory-supplied M6 x 12mm self-tapping screws to attach the protective shroud to the top of the system, covering the busbars between the battery cabinet and input/output cabinet.

## 3.6 Configuring Ground Connections

The UPS is compatible with solidly grounded wye sources or a high-resistance ground system. Refer to [High-Resistance Ground Systems](#) on page 22.

Improper grounding is the largest single cause of UPS installation and startup problems. Grounding techniques vary significantly from site to site, depending on several factors.

Proper grounding should be based on the appropriate NEC sections, but safe and proper equipment operation requires further enhancements. The following pages detail recommendations for grounding various system configurations to ensure optimal UPS system performance.



**WARNING!** In addition to safety requirements it is important to follow grounding best practices for EMC requirements. For example, daisy-chain grounding connection between UPS modules located in different electrical rooms or floors is not recommended.



**CAUTION:** The UPS ground lug must be solidly connected to the service entrance ground by an appropriately sized wire conductor per the NEC. Each conduit or raceway containing phase conductors must also contain a ground wire, both for UPS input and output, which are solidly connected to the ground terminal at each termination point. Conduit-based grounding systems tend to degrade over time. Therefore, using conduit as a grounding conductor for UPS applications may degrade UPS performance and cause improper UPS operation.

### 3.6.1 Three-Wire Input Connections

**IMPORTANT!** Single-phase loads must not be directly connected to the output of a three-wire UPS configuration.

Note that whenever the UPS module transfers to or from bypass, two AC sources (UPS output and bypass) are briefly connected together and circulating current must flow. In this configuration, the current flows through the ground path, possibly tripping ground-fault interrupters (GFIs) and distorting the output voltage waveform. Proper adjustment of ground-fault interrupters is necessary to avoid unwanted tripping. The time delay should be set to at least 0.2 seconds to prevent tripping when the UPS performs a transfer or retransfer operation.

**NOTICE**

Risk of improper installation. Can cause equipment damage.

Failure to set the ground-fault interrupters properly could cause loss of power to the critical load.

**Figure 3.1** Grounding Diagram—Three-Wire Single-Module Systems

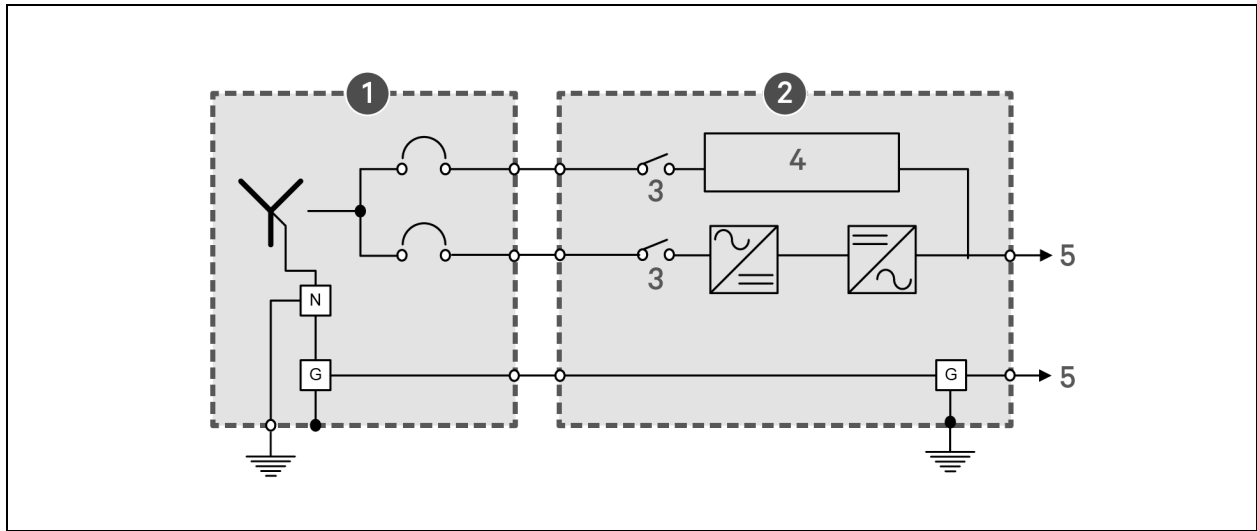

Item	Description
1	Source
2	UPS
3	Optional back-feed disconnect
4	BPSS
5	To connected equipment



Figure 3.2 Grounding Diagram—Three-Wire Multi-Module Systems

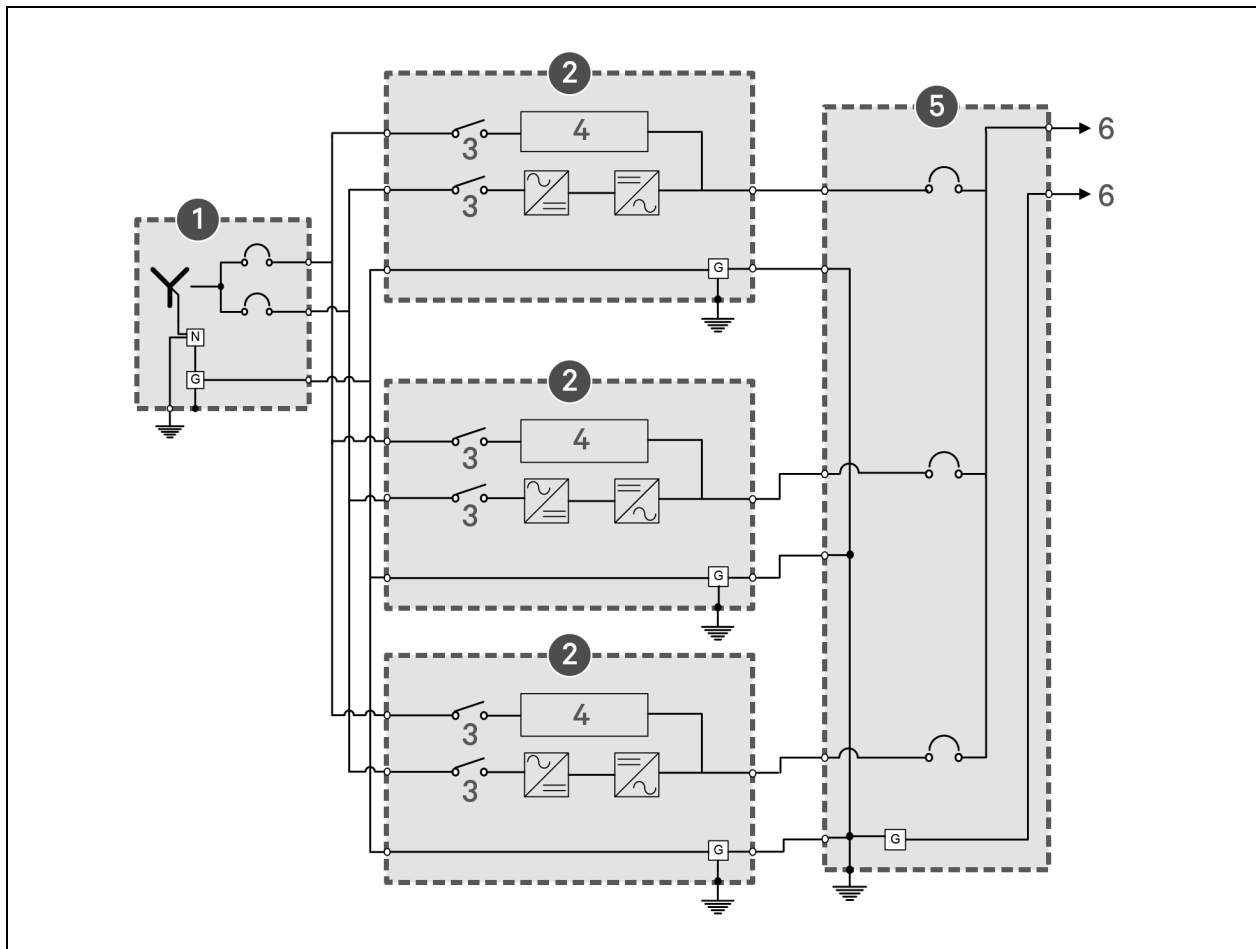

Item	Description
1	Source
2	UPS
3	Optional back-feed disconnect
4	BPSS
5	Switchgear
6	To connected equipment

### 3.6.2 Recommended Grounding Configuration, Battery Systems

Battery cabinet systems must be connected as floating (ungrounded) systems.

Center-tapped or grounded battery systems are not possible with battery cabinet systems.

Whether the battery system is open-rack or cabinet, the metal rack parts or cabinet must be grounded to the UPS module ground bus.

### 3.6.3 High-Resistance Ground Systems

The 250 – 1200kVA UPS units are compatible with High-Resistance Ground (HRG) applications. Contact the factory for HRG compatibility.

## 3.7 Distributed Static Switch (1+N) System Cabling Layouts

The output switchboard must be fitted with module output breakers (MOB) equipped with auxiliary contacts to communicate breaker status. The MOB must function properly with current levels that may occur when switching a module onto the active bus. Breakers with adjustable instantaneous settings should be adequate to achieve this.

**NOTE: Before making any power wiring connections, make sure that you complete all of the interconnections for your system. The interconnects are very hard to access after the power wiring is complete. To make the interconnections, see the appropriate “Interconnection Details” drawing for your system, listed in 2.5 on page 9 .**

The distributed static switch cabling for your UPS system is described in the installation drawings. Refer to the appropriate illustrations for your unit included in [Technical Illustrations](#) on page 55 .

The following table lists the drawings by number, UPS model and options.

**Table 3.1 System-Cabling Layout Drawings**

Drawing Number	Model/Options
<b>Single Module, Single-Input Layouts</b>	
ES1-01-S001	with static bypass
ES1-01-S002	with static bypass and back-feed disconnect
ES1-01-S003	with static bypass and two-breaker external maintenance bypass
ES1-01-S004	with static bypass, two-breaker external maintenance bypass, and back-feed breaker
ES1-01-S005	with single input, static bypass, and three-breaker external maintenance bypass
ES1-01-S006	with static bypass, three-breaker external maintenance bypass, and back-feed disconnect
<b>Single Module, Dual-Input Layouts</b>	
ES1-01-S007	with static bypass
ES1-01-S008	with static bypass and back-feed disconnect
ES1-01-S009	with static bypass and two-breaker external maintenance bypass
ES1-01-S010	with static bypass, two-breaker external maintenance bypass, and back-feed disconnect
ES1-01-S011	with static bypass and three-breaker external maintenance bypass
ES1-01-S012	with static bypass and four-breaker external maintenance bypass
<b>1+N Multi-Module, Single-Input Layouts</b>	
ES1-02-S001	with static bypass and two-breaker paralleling cabinet
ES1-02-S002	with static bypass, two-breaker paralleling cabinet, and back-feed disconnect
ES1-02-S005	without static bypass
<b>1+N Multi-Module, Dual-Input Layouts</b>	
ES1-02-S003	with static bypass and two-breaker paralleling cabinet
ES1-02-S004	with static bypass, two-breaker paralleling cabinet, and back-feed disconnect
<b>Control Cabling Layouts</b>	

**Table 3.1 System-Cabling Layout Drawings (continued)**

Drawing Number	Model/Options
ES1-19-S002	Communications and general contacts
ES1-19-S003	DC source cable layout - UPS with matching battery cabinets
ES1-19-S004	DC source cable layout - UPS with third-party battery cabinets
ES1-19-S005	DC source cable layout - UPS with third-party maintenance-bypass-distribution and battery cabinets
ES1-19-S007	Maintenance bypass cabinet with single module
ES1-19-S024	System controls, distributed static switch (1+N) multi-module and paralleling cabinet

### 3.8 Control Cable and Communication

**NOTE:** The low-voltage conduit plate must be removed prior to punching holes for landing conduit. Failure to do so may result in equipment damage due to metal debris.

For control/alarm wiring, use stranded 16-22AWG cable. Use stranded, 14AWG cable wire up to 500 ft. (150m).

Based on a site's specific needs, the UPS may require auxiliary connections to manage the battery system (external battery circuit breaker), communicate with a building management system or provide alarm signaling to external devices, or for Remote Emergency Power Off (REPO). The connections for the interfaces below are in the low-voltage customer connections on the top of the UPS, see **Figure 3.3** on the next page .

**Table 3.2** on the next page , describes the interfaces.

Figure 3.3 Customer-Connection Locations in All Models

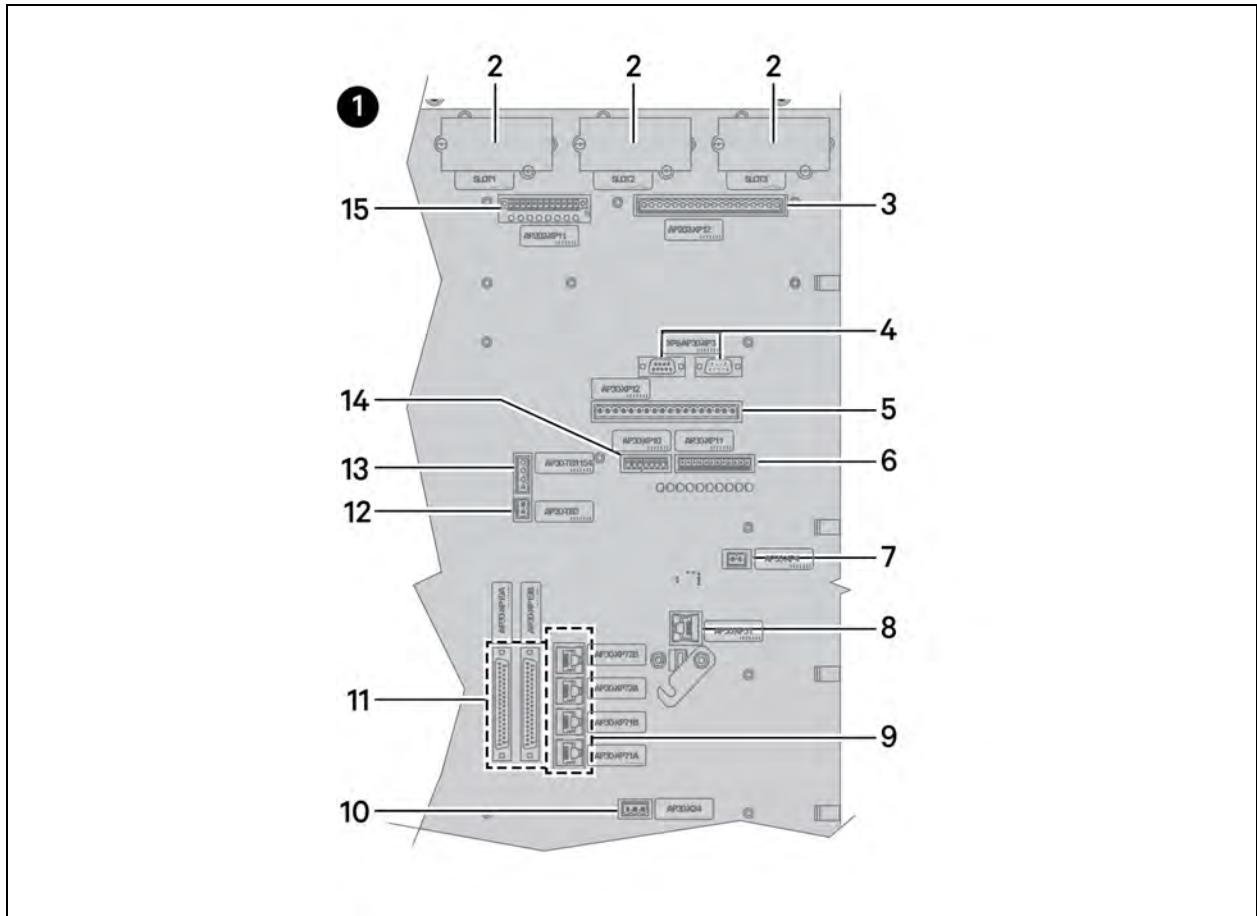

Table 3.2 Connection Interfaces

Item	Description
1	Bottom
2	Slots 1, 2, 3 for Liebert® IntelliSlot™ Communication Cards. <b>NOTE: The center bay is serial interface for LIFE™ Services.</b>
3	AP202-XP12 - Selectable Output Dry Contacts, 6 Form C Contacts
4	XP6-AP30-XP3 - DP-9 Connectors; Serial Interface For Service
5	AP30-XP12 - Selectable Output Dry Contacts, 6 Form C Contacts
6	AP30-XP11 - Selectable Input Dry Contacts; 8 Form A/B or 4 Form C Contacts)
7	Not Used. AP30-XP4
8	AP30-XP31 - Load Bus Sync Port,
9	AP30-XP71A, 71B; AP30-XP72A, 72B - Parallel UPS Communication Connections
10	AP30-XP24 - Back-Feed CB Output Dry Contacts
11	Not Used. AP30-XP19A/19B
12	AP30-TB3 - 24VDC Option Power

**Table 3.2 Connection Interfaces (continued)**

Item	Description
13	AP30-TB1154 - BIB Interface
14	AP202-XP11 - Selectable Input Dry Contacts; 8 Form A/B or 4 Form C Contacts
15	AP30-XP10 - REPO Status

### 3.8.1 Slots for Vertiv™ Liebert® IntelliSlot™ Cards—SLOT1 and SLOT3

These slots permit installing Liebert network communication cards. This adapter provides an independent external network interface for communication with network monitoring and building management systems.

The Liebert IntelliSlot platform includes the Vertiv™ Liebert® IS-UNITY-DP and Vertiv™ Liebert® IS-485 EXI cards. The platform communicates with Vertiv software tools and services, including Vertiv™ *Trellis™*, Vertiv™ Liebert® SiteScan™ Web and Vertiv™ Liebert® Nform.

The Liebert IS-UNITY-DP card supports up to two third-party protocols along with HTTP/S (Web), Vertiv™ Protocol, SMTP and SMS.

Third-party protocols available on the IS-UNITY-DP card are:

- BACnet IP—BACnet over Internet Protocol
- BACnet MSTP—BACnet Master-Slave/Token-Passing (MSTP) communications protocol over an RS-485 serial network (also known as BACnet MSTP RS-485)
- Modbus RTU
- Modbus TCP
- SNMP versions 1, 2c and 3

When determining the protocols, consider the following:

- No more than two protocols may be enabled on one card.
- Only one version of BACnet may be selected, either BACnet IP or BACnet MSTP.
- Only one version of Modbus may be selected, either Modbus TCP or Modbus RTU.
- Only one of the protocols can use the 485 port; choosing two 485 protocols will cause conflicts.

The Liebert IS-485 EXI Card connects to a Liebert® SiteLink-E, allowing Liebert SiteScan Web 4.0 monitoring and control.

### 3.8.2 Slot for Vertiv™ Liebert® LIFE Services Products—SLOT2

This slot is the reserved interface for Liebert LIFE Services modem card. This card provides an independent external modem interface for communication with Liebert LIFE Services service station. Ask your local Vertiv representative for details on Liebert LIFE Services and its benefits for your UPS system.

### 3.8.3 Serial Interface for Liebert LIFE Services Cards (Serial Input/Output)—XP6

The service interface is a SUB-D nine-pin male connector for RS-232 serial communication. It is used for communication with external Liebert LIFE Services or other special Liebert applications.

### 3.8.4 Connector for REPO (Input and Status)—AP30-XP10

The Remote Emergency Power Off (REPO) shuts down the UPS rectifier, inverter and static bypass. It disconnects the external battery circuit breakers, but it does not disconnect the input mains supply to the UPS. If required, this additional action can be performed by adding a contact to the emergency stop switch placed on an upstream breaker.

The REPO button must be connected to the UPS with a twisted/shielded cable no longer than 66 ft. (20m). The contact must be closed under normal operating conditions. When this contact opens, the load will be cut Off and a fault will appear on the display. Resuming normal operation requires resetting the REPO button to its closed position and resetting the fault on the display.

EPO is On when either EPO Input Contact 1 or EPO Input Contact 2 is open. The inputs contacts are independent and in OR logic.

If the EPO button is not installed, jumper leads must be connected between Pins 1 and 2 of EPO Input Contact 1 and between Pins 3 and 4 of EPO Input Contact 2.

The UPS REPO status may be monitored by connecting to the Form-C REPO Status Pins 5, 6 and 7.

**Table 3.3 REPO Connection**

Pin	Signal	Description
1&2	EPO Input Contact #1	EPO is ON when either input 1 or input 2 are open; the inputs are independent and in OR logic
3&4	EPO Input Contact #2	
5	EPO Status Contact - N.C.	Form-C dry contacts rated for 5A @24 VDC
6	EPO Status Contact - COMMON	
7	EPO Status Contact - N.O.	

Use stranded 16-22AWG cable.



**WARNING! The external push button must be voltage-free and isolated from all sources and GND. The external REPO system must not exceed 24V and 20mA.**

**NOTE: The external EPO switch must latch Open when activated.**

### 3.8.5 Customizable Output Dry Contacts—AP30/AP202 XP12

The UPS has two 18-pin screw connectors (AP30-XP12 and AP202-XP12) that allow connecting 12 Form C or Form A/B configurable output contacts. Each contact is rated for 120VAC/5A.

**Table 3.4 Customizable Output Contacts**

TO	FORM C or FORM A/B
AP30: XP12-1	NOT USED
AP30: XP12-2	BFD/RBB BACKFEED PROTECTION TRIP Contact #1 COMMON
AP30: XP12-3	BFD/RBB BACKFEED PROTECTION TRIP Contact #1 N.O.
AP30: XP12-4	SKRU ENABLE CONTACT #2 N.C.
AP30: XP12-5	SKRU ENABLE CONTACT #2 COMMON
AP30: XP12-6	NOT USED

**Table 3.4 Customizable Output Contacts (continued)**

TO	FORM C or FORM A/B
AP30: XP12-7	USER SELECTABLE OUTPUT CONTACT #3 N.C.
AP30: XP12-8	USER SELECTABLE OUTPUT CONTACT #3 COMMON
AP30: XP12-9	USER SELECTABLE OUTPUT CONTACT #3 N.O.
AP30: XP12-10	USER SELECTABLE OUTPUT CONTACT #4 N.C.
AP30: XP12-11	USER SELECTABLE OUTPUT CONTACT #4 COMMON
AP30: XP12-12	USER SELECTABLE OUTPUT CONTACT #4 N.O.
AP30: XP12-13	USER SELECTABLE OUTPUT CONTACT #5 N.C.
AP30: XP12-14	USER SELECTABLE OUTPUT CONTACT #5 COMMON
AP30: XP12-15	USER SELECTABLE OUTPUT CONTACT #5 N.O.
AP30: XP12-16	USER SELECTABLE OUTPUT CONTACT #6 N.C.
AP30: XP12-17	USER SELECTABLE OUTPUT CONTACT #6 COMMON
AP30: XP12-18	USER SELECTABLE OUTPUT CONTACT #6 N.O.
AP202: XP12-1	NOT USED
AP202: XP12-2	INVERTER ON CONTACT #7 COMMON
AP202: XP12-3	INVERTER ON CONTACT #7 N.O.
AP202: XP12-4	NOT USED
AP202: XP12-5	BYPASS ACTIVE CONTACT #8 COMMON
AP202: XP12-6	BYPASS ACTIVE CONTACT #8 N.O.
AP202: XP12-7	NOT USED
AP202: XP12-8	LOAD SUPPLIED BY BATTERY CONTACT #9 COMMON
AP202: XP12-9	LOAD SUPPLIED BY BATTERY CONTACT #9 N.O.
AP202: XP12-10	NOT USED
AP202: XP12-11	RESIDUAL BATTERY AUTONOMY IS EXPIRING CONTACT #10 COMMON
AP202: XP12-12	RESIDUAL BATTERY AUTONOMY IS EXPIRING CONTACT #10 N.O.
AP202: XP12-13	NOT USED
AP202: XP12-14	INVERTER OVERLOAD CONTACT #11 COMMON
AP202: XP12-15	INVERTER OVERLOAD CONTACT #11 N.O.
AP202: XP12-16	NOT USED
AP202: XP12-17	SUMMARY ALARM CONTACT #12 COMMON
AP202: XP12-18	SUMMARY ALARM CONTACT #12 N.O.

Use stranded 16-22AWG cable. The selectable contacts can be customized (by qualified technicians only) to perform the following functions:

Summary Alarm (Fault/Warning)	Inverter Off
Residual Battery Autonomy Is Expiring	Rectifier or Bypass Mains Failure
Inverter On	On Battery
Bypass Active	Maintenance Bypass Switch (MBB) Closed
Inverter Self-locked	Summary Fault
Inverter Overtemperature	Imminent Shutdown
Battery Undervoltage	Inverter Overload
Rectifier Mains Failure	Bypass Mains Failure
Battery Overtemperature	On Generator
Battery Pre-warning Level (Low Battery)	Battery Capacity Level 25%
Battery Capacity Level 50%	Battery Capacity Level 75
Battery Capacity Level 100%	Load Level 25%
Load Level 50%	Load Level 75%
Load Level 100%	Load Level 105%
Line Fault	Summary Alarm Or Line Fault
Power Loss Pre-warning	Power Loss Warning
Load Not Supplied	Eco Mode Active
Remote Back-Feed Breaker	BCB Open
Multi-Module Operating System Detected	



### 3.8.6 Customizable Input Dry Contacts—AP30/AP202 XP11

The UPS contains two 12-pin screw connectors (AP30-XP11 and AP202-XP11) that allow connecting eight Form C or 16 Form A/B configurable output contacts.

**Table 3.5 Customizable input contacts**

Pin	Form C	Form A
AP30: XP11-1	BFD AUX CONTACT #1 N.C.	RBB AUX. CONTACT #1/2 N.O.
AP30: XP11-2	BFD AUX. CONTACT #1 COMMON	RBB AUX. CONTACT/RBB PS OK #1/2 COMMON
AP30: XP11-3	BFD AUX. CONTACT #1 N.O.	RBB PS OK #2 N.O.
AP30: XP11-4	NOT USED	DC GROUND FAULT DET. CONTACT #3 N.O.
AP30: XP11-5	NOT USED	DC GROUND FAULT DET. CONTACT #3/4 COMMON
AP30: XP11-6	NOT USED	USER SELECTABLE INPUT CONTACT #4 N.O.
AP30: XP11-7	NOT USED	MOB AUX. CONTACT #5 N.O.
AP30: XP11-8	NOT USED	MOB AUX. CONTACT #5/6 COMMON
AP30: XP11-9	NOT USED	USER SELECTABLE INPUT CONTACT #6 N.O.
AP30: XP11-10	NOT USED	RFB AUX. CONTACT #7 N.O.
AP30: XP11-11	NOT USED	RFB AUX. CONTACT #7/8 COMMON
AP30: XP11-12	NOT USED	USER SELECTABLE INPUT CONTACT #8 N.O.
AP202: XP11-1	NOT USED	MBB AUX. CONTACT #9 N.O.
AP202: XP11-2	NOT USED	MBB AUX. CONTACT #9/10 COMMON
AP202: XP11-3	NOT USED	USER SELECTABLE INPUT CONTACT #10 N.O.
AP202: XP11-4	NOT USED	MIB AUX. CONTACT #11 N.O.
AP202: XP11-5	NOT USED	MIB AUX. CONTACT #11/12 COMMON
AP202: XP11-6	NOT USED	USER SELECTABLE INPUT CONTACT #12 N.O.
AP202: XP11-7	USER SELECTABLE INPUT CONTACT #7 N.C.	USER SELECTABLE INPUT CONTACT #13 N.O.
AP202: XP11-8	USER SELECTABLE INPUT CONTACT #7 Common	USER SELECTABLE INPUT CONTACT #13/14 Common
AP202: XP11-9	USER SELECTABLE INPUT CONTACT #7 N.O.	USER SELECTABLE INPUT CONTACT #14 N.O.
AP202: XP11-10	SKRU STATUS CONTACT #8 N.C.	NOT USED
AP202: XP11-11	SKRU STATUS CONTACT #8 COMMON	NOT USED
AP202: XP11-12	SKRU STATUS CONTACT #8 N.O.	NOT USED

Use stranded 16-22AWG cable. The selectable input contacts can be customized by qualified service technicians to perform the functions below.



**WARNING! Use no-voltage contacts to drive the inputs. Do not use voltages supplied by an external power supply.**

- On Generator
- Mirrored on Generator
- Fast Power Off
- External Maintenance Bypass CB
- Fault Acknowledge
- External Output CB (MOB)
- Maintenance Isolation Breaker (MIB)
- Disable Inverter Start
- Force Rectifier Off/On
- DC Ground Fault Detection
- Disable Bypass SS
- Disable Battery Charging
- External Remote Feed CB Status
- External Remote Back-Feed CB Status
- External Load Bank CB Status System
- External Load Bank CB Status Module
- Remote Enable
- Remote Transfer to Bypass
- Remote Transfer to Inverter

### Remote Control Using Programmable Logic Controllers (PLC)

The UPS provides an external control interface for maintenance bypass switchgear equipped with a key interlock system and to manage a battery system. The interface provides (8) Form C or (16) selectable Form A/B programmable input dry contacts, and (12) Form C output dry contacts that can also be configured as Form A/B programmable output dry contacts. Programmable contacts can be customized to meet customer needs and to integrate with remote controls.

**Figure 3.4** on the facing page illustrates the location of each breaker for a typical UPS system, and **Table 3.6** on the facing page describes available programmable input contacts for external circuit breakers.

While the programmable contacts allow flexibility for integration with external controls, it is important to note that any UPS input contact programmed to reflect the status of a breaker must be supplied by an auxiliary contact of that breaker. The status of a breaker should not be supplied to the UPS input contacts by PLC logic-driven output contacts.

Each UPS input contact can be programmed to reflect the state of a single breaker only and should not receive multiple breaker status signals (that is, no piggybacking signals). Failure to adhere to these guidelines may result in unintended operation, damage to the equipment, or even a critical load loss. Any customers planning Liebert® EXL S1 installations that incorporate PLC remote control should contact Vertiv Applications Engineering for guidance.

Figure 3.4 External Circuit Breakers in a Typical System

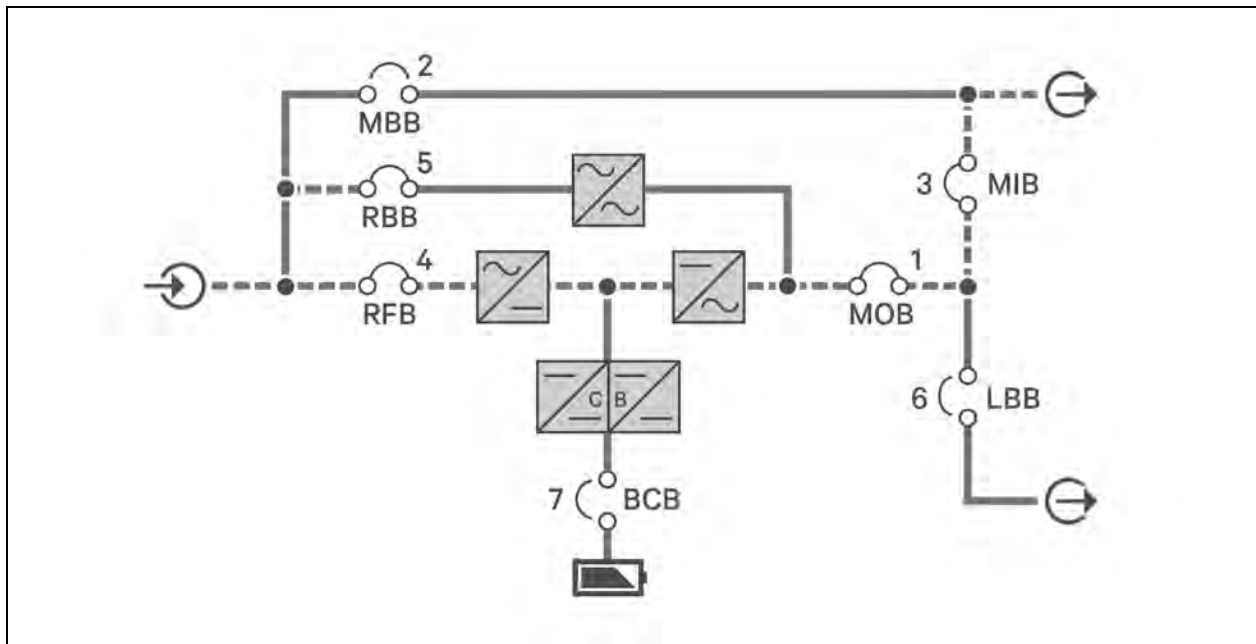

Table 3.6 Programmable Input Contacts for External Circuit Breakers

Item		
1	Module Output Breaker (MOB)	The MOB isolates the output of the UPS from the critical load or collective bus of a parallel UPS system. It is typically located in a system paralleling cabinet, system control cabinet, switchgear, or switchboard.
2	Maintenance Bypass Breaker (MBB)	The MBB isolates an alternate source from the critical load. It is typically located in a maintenance bypass cabinet, system paralleling cabinet, system control cabinet, switchgear, switchboard, or panel board.
3	Maintenance Isolation Breaker (MIB)	The MIB isolates the UPS system from the critical load. It is typically located in a maintenance bypass cabinet, system paralleling cabinet, system control cabinet, switchgear, switchboard, or panel board.
4	Rectifier Feed Breaker (RFB)	The RFB isolates the UPS rectifier input. It is typically located in switchgear, a switchboard, or a panel board.
5	Remote Back-Feed Breaker (RBB)	The RBB isolates the UPS static bypass switch input. It is typically located in switchgear, a switchboard, or a panel board.
6	Load Bank Breaker (LBB)	The LBB connects the output of the UPS or the critical load to a load bank for testing. It is typically located in switchgear, a switchboard, or a panel board.
7	Battery Circuit Breaker (BCB)	The BCB isolates the DC/DC converter of the UPS from the battery system. The BCB is typically co-located with the battery system.

### 3.8.7 Connector for Parallel UPS Connection—AP30-XP71A, 71B, AP30-XP72A, 72B

This interface is used for paralleling two or more UPS's with each other.

### 3.8.8 RJ-45 Interface for Synchronization with External Signal—AP30-XP31

This interface is used to communicate with an external synchronization device, such as Load Bus Sync Module (for two modules only) or the Multibus Sync Module (for up to 11 modules). See the manuals related to these options for more details.

The interface can be used to synchronize the outputs of multiple UPS devices, even when they do not have a common output. This enables an external static switching device to communicate between UPS outputs in the event of a malfunction, without creating synchronization problems.

### 3.8.9 UPS Control Contacts with Battery Cabinet or Module Battery Disconnect

These contacts are used to communicate between the UPS module and battery cabinets or Module Battery Disconnects.

**Table 3.7 Battery Control Interface**

Terminal Block	Pin	Connects to (Description of External Item)
AP30-TB1154	1	CAN +24 V - Battery Interface Board TB1154-1
	2	Ground - Battery Interface Board TB1154-2
	3	CANbus High - Battery Interface Board TB1154-3
	4	CANbus Low - Battery Interface Board TB1154-4

Use Belden 9156 equivalent wire. Total length of cable from the UPS to all battery interface connections must be less than 1000 ft. (300m).

### 3.8.10 UPS Control Contacts with Global Maintenance Bypass

These contacts are used to communicate between the UPS module and the Maintenance Bypass.

**Table 3.8 Maintenance Bypass Key Status**

Terminal Block	Pin	Description
AP202:XP11	10	Key status switch, closed = key inserted
	11	Key status switch, common
	12	Key status switch, closed = key removed
<ol style="list-style-type: none"> <li>See <a href="#">Distributed Static Switch (1+N) System Cabling Layouts</a> on page 22 for 1+N systems with a Maintenance Bypass.</li> <li>Key Status Input must be Form C contact.</li> </ol>		

For control/alarm wiring, use stranded 16-22AWG cable. Use stranded 14AWG cable wire up to 500 ft. (150m).

**Table 3.9 Maintenance Bypass SKRU Enable**

Terminal Block	Pin	Description
AP30:XP12	4	Maintenance Bypass Cabinet, closed = load not on inverter
	5	Maintenance Bypass Cabinet, common
<ol style="list-style-type: none"> <li>For 1+N systems with a maintenance bypass, these contacts must be run to each module from an isolated source.</li> <li>These contacts must be run separately from all other control cables.</li> </ol>		

## 3.9 Top Entry Low-Voltage

**NOTE:** The low-voltage conduit plate must be removed prior to punching holes for landing conduit. Failure to do so may result in equipment damage due to metal debris.

Remove the low-voltage conduit plate (at the top of the unit and then expose the area by removing the inside cover plate), punch the conduit holes, land the conduit and then route the control wire to the customer connections.

**NOTE:** Before making any power wiring connections, make sure that you complete all of the interconnections for your system. The interconnects are very hard to access after the power wiring is complete. To make the interconnections, see the appropriate “Interconnection Details” drawing for your system, listed in **2.5** on page **9** .

## 3.10 Bottom Entry Low-Voltage

Remove the low-voltage conduit plate (at the bottom of the unit and then expose the area by removing the inside cover plate), punch the conduit holes, land the conduit and then route the control wire to the as shown in **Figure 3.5** on the next page toward the top of the unit.

**NOTE:** Before making any power wiring connections, make sure that you complete all of the interconnections for your system. The interconnects are very hard to access after the power wiring is complete. To make the interconnections, see the appropriate “Interconnection Details” drawing for your system, listed in **2.5** on page **9** .

The input/output cabinet shown in **Figure 3.5** on the next page , is an example of the wiring route. Routing through other cabinets is similar.

Figure 3.5 Low-Voltage Cable Routing Example

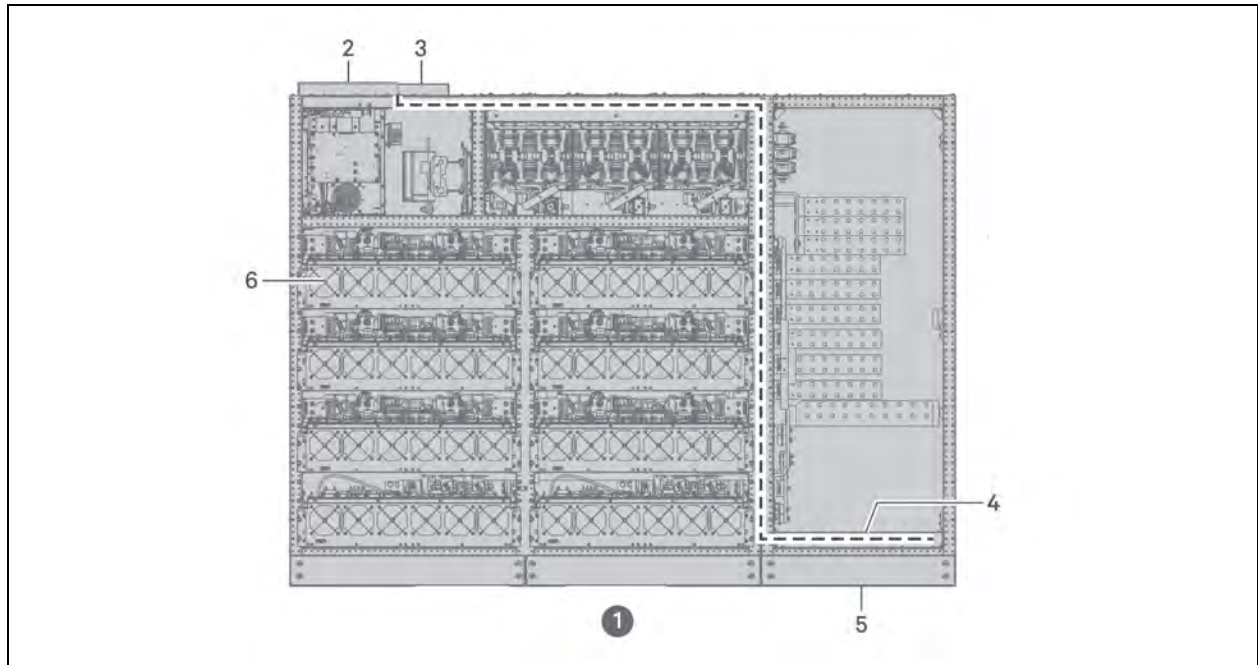

Item	Description
1	Front view (doors and panels not shown)
2	Box mounting cover low-voltage top
3	Conduit box <b>NOTE: The low-voltage conduit plate must be removed prior to punching holes for landing conduit. Failure to do so may result in equipment damage due to metal debris.</b>
4	Low-voltage cable route
5	Bottom-entry low-voltage conduit box
6	Fans

## 4 Optional Equipment

### 4.1 Options

**NOTE: Although not required, Vertiv™ recommends that all UPS installations incorporate a solenoid key release unit (SKRU) as part of the maintenance bypass cabinet or switch board. Improper load transfers between the UPS Inverter and Maintenance Bypass may result in equipment damage and loss of load.**

A number of options are available from for the Liebert® EXL S1. (Some options are not available for all ratings.) below are the most frequently provided options. Others are available. Contact your Vertiv representative for more information.

- **DC (Battery) Ground Fault**—Enables the detection and annunciation of battery DC ground faults in order to facilitate proactive resolution of such ground faults for 2014 NEC compliance. The UPS can be configured to allow the circuit breaker to open or remain closed upon detection of a ground fault.
- **Liebert IntelliSlot Cards (3 Ports)**—Provides web, embedded Vertiv LIFE™ Technology, Vertiv Protocol, SNMP, BACnet IP/MSTP, Modbus TCP/RTU, SMTP, SMS and telnet communication and control capabilities in one, unified communication platform.
- **Load Bus Synchronization (LBS)**—Allows synchronizing the outputs of two or more modules when the source for one of more modules supplied by a separate non-synchronized source.
- **Local EPO Button**—A local EPO button with protective cover is available. This option is typically installed at the factory but may be field-installed by a Vertiv technician.
- **Maintenance Bypass**—This switchboard provides make-before-break maintenance bypass. It includes: Maintenance Bypass Breaker (MBB) and Maintenance Isolation Breaker (MIB). The Maintenance Bypass is a buyout item and not available from Vertiv.
- **Remote Alarm Status Panel**—Provides alarm lamps for up to eight UPS alarms. Power provided via AP30-TB3.
- **Seismic Bracing**—A separate kit for tying down the UPS module allows the unit to meet International Building Code (IBC) regulations.
- **Temperature Sensor**—Allows the UPS module to compensate battery charging voltage, depending on temperature, to prolong battery life. The Temperature Sensor is required for battery solutions utilizing a non-matching Module Battery Disconnect or Battery Isolation Switch. Liebert battery packs have built-in temperature sensors. The Temperature Sensor option includes a remote sensor that must be field-installed.
- **Battery and Racks**—The batteries provide power in the event of a power outage. The EXL S1 can use a variety of battery types, provided the battery plant is designed for the UPS DC voltage range and the load requirements of the application.
- **Battery Cabinets**—Available battery types are flooded-cell; valve-regulated, lead-acid; and lithium-ion. The battery cabinets are designed to be either attached to the UPS or separate from the UPS.
- **Battery Interface Box**—A Battery Interface Box (BIB) is available to support the UPS and third-party battery cabinets or rack-mounted batteries. A BIB is required for each MBD (stand-alone or inside the third-party battery cabinet). A BIB is optional with each Battery Isolation Switch. A BIB is required for each temperature sensor.
- **Flywheel Energy Storage System**—An optional Vycon Flywheel Energy Storage System is available, consisting of the number of Vycon flywheel units in separate cabinets necessary to provide the specified operating time. Each flywheel unit has an internal circuit breaker for isolating the flywheel from the UPS and a control interface to the UPS module. Installer provides interconnect cabling.
- **Battery Isolation Switch**—A Battery Isolation Switch (BIS) is used to isolate individual battery strings when a system MBD is used. When the optional Battery Interface Box is used, the status of the Battery Isolation Switch is displayed on the UPS HMI. A temperature sensor is recommended to allow proper battery charging and overtemperature protection.

- **Module Battery Disconnect**—The UPS system utilizes a separate Module Battery Disconnect (MBD) for remotely located batteries. A sensing circuit in the UPS module, set at the battery low-voltage limit, trips the Module Battery Disconnect to safeguard the battery from excessive discharge. The Module Battery Disconnect has an undervoltage release mechanism designed to ensure that during any shutdown or failure mode all battery potential is removed from the UPS system.
- **Alber™ Monitoring System**—The matching Liebert® Battery Cabinet allows installing an optional Alber™ battery monitoring system in the cabinet. The Alber battery monitoring continuously checks all critical battery parameters, such as cell voltage, overall string voltage, current and temperature.

## 4.2 Rectifier Feed Breaker (RFB)

For systems that use a Rectifier Feed Breaker (RFB), the controls for the Aux contact and UVR/shunt trip will go between the remote breaker and the UPS I/O and Customer Connectivity sections. Power for the UVR/shunt trip is customer-supplied.

**Table 4.1 Rectifier Feed Breaker Specifications**

Power Class	kAIC Rating	RFB Specification	RFB General Specification	Comments
250-1200kVA	100 kA Module	UL-Listed 489 (Molded Case Circuit Breaker) or UL 1066 (Low Voltage AC Power Circuit Breaker), which are required for use in UL-listed switchgear or switchboards. The circuit breaker must have a short-time rating of 100kA at a maximum voltage of 480V for three cycles.	The remote breaker must be equipped with auxiliary contacts for proper operation with the UPS.	UPS internal fuse protection exists on rectifier and bypass input.

### 4.2.1 Remote Back-Feed Breaker

For systems that use a Remote Back-Feed Breaker (RBB), the controls for the Aux contact and 120V shunt trip will go between the remote breaker and the UPS I/O and Customer Connectivity sections. Power for the shunt trip is factory-supplied and wired according to the following diagram.

**Table 4.2 Remote Back-Feed Breaker specifications**

Power Class	kAIC Rating	RFB Specification	RBB General Specification	Comments
250-1200kVA	100kA Module	UL-Listed 489 (Molded Case Circuit Breaker) or UL 1066 (Low Voltage AC Power Circuit Breaker), which are required for use in UL-listed switchgear or switchboards. The circuit breaker must have a short-time rating of 100kA at a maximum voltage of 480V for three cycles.	The remote breaker must be equipped with shunt trip and auxiliary contacts for proper operation with the UPS.	UPS internal fuse protection exists on rectifier and bypass input.



Figure 4.1 Remote Back-Feed Breaker Diagram

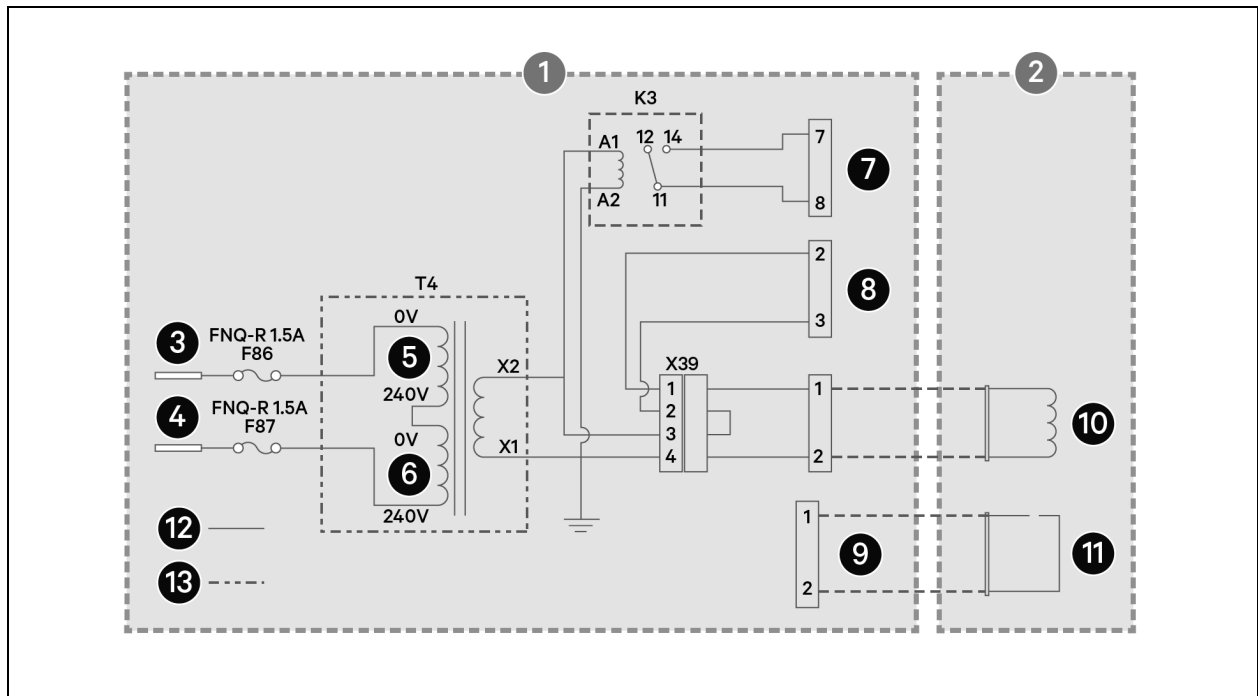

Item	Description
1	Inside UPS
2	Inside Switchgear
3	Phase A critical bus
4	Phase B critical bus
5	Bottom
6	Top
7	P/S OK signal customer-input contact AP30-XP11 (factory-wired)
8	Back-feed active customer-output contact AP30-XP12 (factory-wired)
9	RBB Aux. contact customer-input contact AP30-XP11
10	External, 120V shunt trip
11	RBB Aux. contact

**NOTE:** All wires can be 18AWG. Control wiring by others.

### 4.3 Multi-Module System Options and Accessories

The accessories and options for single-module systems may be applied to the individual modules in a multi-module (1+N) system or a synchronized dual-bus (2N) system.

### 4.3.1 Paralleling Cable Kit

Module-to-module communication cables are required for 1+N parallel systems. A kit with RJ-45 connectors ships with each multi-module Liebert® EXL S1 UPS. At least one kit is required for each added UPS module; the number of kits required is one fewer than the number of UPS modules in the 1+N system (for example, six UPS modules would require five kits).

**NOTE: Verify appropriate strain relief for all parallel communication cables to ensure that there is no tension or pressure on the RJ-45 to AP30-XP71 and AP30-XP72 connections.**

Parallel communication cables must be selected from one of the suppliers to be compatible with the RJ-45 connector on the EXL S1. Vertiv™ Part # 564556P1 supplied or ordered with multi-module systems. Contact the factory for details. Approved parallel cable suppliers:

- Alpha Wire Corp., Part #2214C
- Belden, Part #8304
- General Cable, Part #C0723A

### 4.3.2 Multi-Bus Synch Module (MBSM)

This module is available to support six or up to 11 UPS modules, and is generally configured to synchronize all modules to a reference bus (e.g., bypass line). See the manual for this module for more details.

## 5 Specifications

**Table 5.1 Specifications and Standards**

UPS Rating (kVA)	400/500	250/300/400	500/600	625/750/800	1000/1100/1200
Output Active Power at 104°F (40°C), kW	400/500	250/300/400	500/600	625/750/800	1000/1100/1200
<b>Input AC Parameters</b>					
Input Voltage to Rectifier, VAC	415, 3-Phase, 4-Wire	480, 3-Phase, 3-Wire			
Input Voltage to Bypass, VAC	415, 3-Phase, 4-Wire	480, 3-Phase, 3-Wire			
Permissible Input Voltage Range	+10%, -15%				
Input Frequency, Hz	60				
Permissible Input Frequency Range, Hz	55 to 65				
Input Power Factor	≥ 0.99				
Input Current Distortion (THDi) at Nominal Voltage at Full Load, %	≤ 3.0 with Input Voltage Distortion (THDv) <1%				
Power Walk-In (seconds)	1 to 300 (Selectable in 1 Second Increments)				
Input/Bypass Withstand Rating	100 kA				
<b>Battery and DC Parameters</b>					
Battery Type	Lithium-Ion; VRLA (Valve-Regulated, Lead Acid); VLA (Vented Lead Acid)				
Nominal Battery Bus, VDC	480				
Battery Float Voltage, VDC	540				
DC Ripple at Float Voltage	< 1.0% (RMS value) < 3.4% Vpp				
Temperature Compensated Battery Charging	Standard with Vertiv™ Battery Cabinets				
<b>Output Parameters</b>					
Load Power Factor Supported (Without Derating)	0.7 Leading to 0.4 Lagging				
Output Voltage, VAC	480, 3-Phase, 3-Wire				
Output Voltage Regulation, %	< 1.0 (3-Phase RMS Average)				
Output Voltage Regulation (50% Unbalanced Load), %	< 2.0 (3-Phase RMS Average)				
Output Frequency, Hz	60				
Output Frequency Regulation, %	± 0.1				
Output THD at Nominal Voltage (Linear Load), %	≤ 1.5 (RMS Value)				

**Table 5.1 Specifications and Standards (continued)**

UPS Rating (kVA)	400/500	250/300/400	500/600	625/750/800	1000/1100/1200
Output THD at Nominal Voltage Including a 100kVA Non-Linear Load per IEC 62040-3, %	≤ 5.0 (RMS Value)				
Efficiency AC-AC Double Conversion with DC Source Disconnected	Up to 97% maximum efficiency				
Efficiency AC-AC Eco Mode and Dynamic Online Mode with DC Source Disconnected	Up to 99% maximum efficiency				
Transient Recovery	IEC 62040-3, section 5.3.1 Figure 1				
Voltage Displacement (Balanced Loads)	120 degrees ± 1 degree				
Voltage Displacement (50% Unbalanced Loads)	120 degrees ± 2 degrees				
Overload at Nominal Voltage and 77°F (25°C)	110% continuously; 125% for 10 minutes; 150% for 60 seconds; 200% for 200 milliseconds				
<b>Physical Characteristics</b>					
Dimensions, WxDxH, in. (mm)	See <b>Table 5.2</b> on the facing page .				
Color	Black (RAL 7021)				
Protection Class, UPS Enclosure	NEMA 1, IP 20 (with and without front door open)				
<b>Environmental</b>					
Operating Temperature	32°F to 104°F (0°C to 40°C)				
Relative Humidity	0% to 95%, maximum non-condensing for operation and storage				
Operating Altitude, ft. (m)	Up to 3300 (1000) without derating				
Acoustical Noise, dBA	78 (72 at partial load)				
<b>General and System Data</b>					
Inverter Type	High-Efficiency, Transformer-Free IGBT, Three-Level PWM Inverter				
Rectifier Type	High-Efficiency, Transformer-Free IGBT, Three-Level PWM Inverter				
Parallel Configuration	Up to 8 units in parallel				
Access	Front and Top (no rear access required)				
<b>Communication</b>					
Options	2 Liebert® IntelliSlot™ Bays				
Card Compatibility	Liebert® IS-UNITY-DP, Liebert® IS-485EXI				
Protocols Available	Modbus-IP, Modbus-485, BACnet-IP, BACnet-MSTP, SNMP, HTTP, LIFE™ Services				
<b>Standards</b>					
Transportation	ISTA Procedure 3B				
Safety	UL 1778 5th Edition; CSA 22.2 NO 107.3				

**Table 5.1 Specifications and Standards (continued)**

UPS Rating (kVA)	400/500	250/300/400	500/600	625/750/800	1000/1100/1200
EMI	IEC 62040-2; FCC Part 15, Class A				
Surge	ANSI C62.41, Category B3				
Electrostatic Discharge (ESD) Immunity	IEC 61000-4-2 Level 2 (4kV) contact; Level 3 (8kV) air				
Seismic	IBC 2018, CBC 2019, ASCE, OSHPD Consult the factory for further details.				
UL9540	If installing per UL9540, "Compliance Between EXL-S1 UPS and Samsung ESS": The Samsung ESS has been Fire Propagation in accordance with UL9540A, Project number 4789212736.				
Maximum Rated Energy Capacity	34.6 kWh				
Minimum Distance Between UPS Systems	20 mm from battery room walls				
UL9540 Seismic Rating	If installing per UL9540, "Compliance Between EXL-S1 UPS and Samsung ESS": Samsung ESS with CBC 2019 and IBC 2018.  EXL-S1 S <sub>DS</sub> = 1.54, Z/H = 1.0 S <sub>DS</sub> = 1.61, Z/H = 0  Samsung ESS S <sub>DS</sub> = 1.70, Z/H = 1.0 S <sub>DS</sub> = 2.15, Z/H = 0  I <sub>p</sub> = 1.5				

**Table 5.2 Dimensions and Weights—with and without options**

UPS Rating		Installed Options				Dimensions WxDxH, in. (mm)	Approximate Weight Unpackaged, lb (kg)
kVA	kW	Voltage	Back-Feed Disconnect (BFD)	Bypass (Sharing) Inductors	Common Mode Choke		
400/500	400/500	415	—	—	—	63.0 x 36.0 x 79.1 (1600 x 914 x 2009)	2450 (1111)
400/500	400/500	415	x	—	—	74.8 x 36.0 x 79.1 (1900 x 914 x 2009)	2749 (1247)
400/500	400/500	415	—	x	—		2749 (1247)
400/500	400/500	415	x	x	—		2850 (1293)
250/300/400	250/300/400	480	—	—	—	51.2 x 36 x 79.1 (1300 x 914 x 2009)	1,869 (848)
250/300/400	250/300/400	480	x	—	—	63 x 36 x 79.1 (1600 x 914 x 2009)	2168 (984)
250/300/400	250/300/400	480	—	x	—	63 x 36 x 79.1 (1600 x 914 x 2009)	2168 (984)
250/300/400	250/300/400	480	x	x	—	63 x 36 x 79.1 (1600 x 914 x 2009)	2269 (1030)
500/600	500/600	480	—	—	—	63 x 36 x 79.1 (1600 x 914 x 2009)	2450 (1111)

**Table 5.2 Dimensions and Weights—with and without options (continued)**

UPS Rating		Voltage	Installed Options			Dimensions WxDxH, in. (mm)	Approximate Weight Unpackaged, lb (kg)	
kVA	kW		Back-Feed Disconnect (BFD)	Bypass (Sharing) Inductors	Common Mode Choke			
500/600	500/600	480	x	—	—	74.8 x 36 x 79.1 (1900 x 914 x 2009)	2749 (1247)	
500/600	500/600	480	—	x	—		2749 (1247)	
500/600	500/600	480	x	x	—		2850 (1293)	
625/750/800	625/750/800	480	—	—	—	78.8 x 36 x 79.1 (2002 x 914 x 2009)	3508 (1591)	
625/750/800	625/750/800	480	x	—	—	109.3 x 36 x 79.1 (2777 x 914 x 2009)	4258 (1931)	
625/750/800	625/750/800	480	—	x	—		4428 (2009)	
625/750/800	625/750/800	480	—	—	x		4787 (2171)	
625/750/800	625/750/800	480	x	x	—		4558 (2067)	
625/750/800	625/750/800	480	x	—	x		5096 (2312)	
625/750/800	625/750/800	480	—	x	x		5457 (2475)	
625/750/800	625/750/800	480	x	x	x		5665 (2570)	
1000/1100/1200	1000/1100/1200	480	—	—	—		104.5 x 36 x 79.1 (2654 x 914 x 2009)	4546 (2062)
1000/1100/1200	1000/1100/1200	480	x	—	—		128.1 x 36 x 79.1 (3254 x 914 x 2009)	5116 (2321)
1000/1100/1200	1000/1100/1200	480	—	x	—	5286 (2398)		
1000/1100/1200	1000/1100/1200	480	—	—	x	5645 (2561)		
1000/1100/1200	1000/1100/1200	480	x	x	—	5416 (2457)		
1000/1100/1200	1000/1100/1200	480	x	—	x	5954 (2701)		
1000/1100/1200	1000/1100/1200	480	—	x	x	6315 (2864)		
1000/1100/1200	1000/1100/1200	480	x	x	x	6523 (2959)		

Minimum clearance above the UPS is 2 ft. (0.6m).

Top or bottom cable entry are available through removable access plates. Cut plate to suit conduit size. If aluminum cable is to be used, top and bottom cable entry may be required. Contact Applications Engineering for assistance.

Control wiring and power cables must be run in separate conduits. Control wiring must be stranded tinned conductors.

**Table 5.3 Environmental Specifications**

Parameter	Specification
Enclosure	The UPS is housed in a NEMA-1 enclosure. The enclosure is designed for indoor use only and is not to be subjected to falling objects or precipitation.
Recommended Operating Temperature, °F (°C)	77 (25) ambient
Maximum Operating Temperature, °F (°C)	104 (40) ambient (design temperature) without derating

**Table 5.3 Environmental Specifications (continued)**

Parameter	Specification
Minimum Operating Temperature, °F (°C)	32 (0)
Storage Temperature, °F (°C)	-4 to 104 (-20 to 40). Contact factory for information about storage above 104°F (40°C)
Typical Battery Temperature Requirements	Average annual temperature must not exceed 80°F (27°C). Peak temperature must not exceed 109°F (43°C). See battery manufacturer's recommendations.
Relative Humidity	0% to 95%, maximum non-condensing for operation and storage
Operating Elevation	Sea level to 3300 ft (1000 m) without derating
Storage Elevation	Sea level to 50,000 ft (15,240 m)
Acoustical Noise at 39 inches (990 mm), dBA	78 (72 at partial load)

**Table 5.4 Current ratings—rectifier input**

UPS Rating		Voltage, VAC	Nominal Current	Maximum Current
kVA	kW			
400	400	415	576	645
500	500	415	722	804
250	250	480	310	350
300	300	480	373	420
400	400	480	499	560
500	500	480	624	695
600	600	480	749	835
625	625	480	780	870
750	750	480	937	1040
800	800	480	999	1110
1000	1000	480	1247	1390
1100	1100	480	1373	1530
1200	1200	480	1499	1574
1200	1200	480	1499	1670

**Table 5.5 Current ratings—bypass**

UPS Rating		Voltage VAC	Nominal Current
kVA	kW		
400	400	415	556
500	500	415	696
250	250	480	301

**Table 5.5 Current ratings—bypass (continued)**

UPS Rating		Voltage VAC	Nominal Current
kVA	kW		
300	300	480	361
400	400	480	481
500	500	480	601
600	600	480	722
625	625	480	752
750	750	480	902
800	800	480	962
1000	1000	480	1203
1100	1100	480	1323
1200	1200	480	1443

**Table 5.6 Current ratings—Output**

UPS Rating		Voltage, VAC	Nominal Current
kVA	kW		
400	400	415	556
500	500	415	696
250	250	480	301
300	300	480	361
400	400	480	481
500	500	480	601
600	600	480	722
625	625	480	752
750	750	480	902
800	800	480	962
1000	1000	480	1203
1100	1100	480	1323
1200	1200	480	1443



**Table 5.7 Current ratings—battery**

UPS Rating		Input Voltage VAC	Nominal VDC	Maximum Battery Current, EOD
kVA	kW			
400	400	415	480	1034
500	500	415	480	1294
250	250	480	480	647
300	300	480	480	776
400	400	480	480	1036
500	500	480	480	1294
600	600	480	480	1555
625	625	480	480	1618
750	750	480	480	1943
800	800	480	480	2073
1000	1000	480	480	2588
1100	1100	480	480	2849
1200	1200	480	480	3110

**Notes on Tables**

1. Maximum current includes nominal input current and maximum battery recharge current (considered non-continuous). Continuous and non-continuous current limits are defined in NEC 100. Values shown for maximum current are 110% of nominal input current, except for 1200kVA/kW module with 1600A breaker. This 1200kVA/kW module has a maximum current of 105% of nominal input current. Contact Applications Engineering for support in configuring a 1200kVA/kW module with a 1600A external rectifier input breaker.
2. For breaker coordination while the module is overloaded, see the current-versus-time values on the overload curves.
3. Nominal battery voltage is shown at 2.0 volts/cell.
4. Maximum battery current at end of discharge level of 1.67 volts per cell (240 cells).
5. Nominal AC output current (considered continuous) is based on full rated output load.
6. Bypass AC input current (considered continuous) is based on the full rated output load.

**Table 5.8 Current-versus-time curves of inverter overload capacity**

Ambient Temperature							
77°F (25°C)		86°F (30°C)		95°F (35°C)		104°F (40°C)	
Time, sec.	Load %	Time, sec.	Load %	Time, sec.	Load %	Time, sec.	Load %
0.2	200%	0.2	200%	0.2	200%	0.2	200%
1	158%	1	158%	1	158%	1	158%
28	155%	30	155%	15	155%	19	155%

**Table 5.8 Current-versus-time curves of inverter overload capacity (continued)**

Ambient Temperature							
77°F (25°C)		86°F (30°C)		95°F (35°C)		104°F (40°C)	
Time, sec.	Load %	Time, sec.	Load %	Time, sec.	Load %	Time, sec.	Load %
50	152%	47	152%	30	152%	28	152%
330	130%	155	130%	90	130%	40	130%
600	125%	210	125%	115	125%	47	125%
—	110%	—	110%	207	110%	77	102%

Based on nominal input voltage and no battery charging.

**Table 5.9 Current-versus-time curves of bypass overload capacity, 104° (40°C)**

% Load	Overload Time, sec.
110	750
125	300
130	210
152	19
155	5.45
158	5.17
165	0.61

Based on nominal input voltage

**Table 5.10 Recommended conduit and cable sizes**

UPS Rating		Voltage (VAC)	Cable Entry	(# of conduits); size of conduits; # -size of phase cables per conduit; size of cable for ground per conduit	
kVA	kW			Copper Conductors	Aluminum Conductors
<b>RECTIFIER INPUT</b>					
400	400	415	Top	3 - 3" (350 kcmil/ph+2x350 kcmil+1/0 awg gnd)	4 - 3" (350 kcmil/ph+2x350 kcmil ntrl+3/0 awg gnd)
			Bottom	3 - 3.5" (350 kcmil/ph+2x350 kcmil+1/0 awg gnd)	4 - 3.5" (350 kcmil/ph+2x350 kcmil ntrl+3/0 awg gnd)
500	500	415	Top	3 - 3.5" (500 kcmil/ph+2x500 kcmil ntrl+1/0 awg gnd)	4 - 3" (350 kcmil/ph+2x350 kcmil ntrl+3/0 awg gnd)
			Bottom	3 - 4" (500 kcmil/ph+2x500 kcmil ntrl+1/0 awg gnd)	4 - 3.5" (350 kcmil/ph+2x350 kcmil ntrl+3/0 awg gnd)
250	250	480	Top	1 - 3" (500kcmil/ph+3 awg gnd)	2 - 2" (4/0 awg/ph+1 awg gnd)
			Bottom	1 - 3" (500 kcmil/ph+3 awg gnd)	2 - 2.5" (4/0 awg/ph+1 awg gnd)
300	300	480	Top	2 - 2" (4/0 awg/ph+2 awg gnd)	2 - 2.5" (300 kcmil/ph+1/0 awg gnd)
			Bottom	2 - 2.5" (4/0 awg/ph+2 awg gnd)	2 - 3" (300 kcmil/ph+1/0 awg gnd)
400	400	480	Top	2 - 2.5" (350 kcmil/ph+1 awg gnd)	2 - 3" (500 kcmil/ph+2/0 awg gnd)
			Bottom	2 - 3" (350 kcmil/ph+1 awg gnd)	2 - 3.5" (500 kcmil/ph+2/0 awg gnd)
500	500	480	Top	3 - 2.5" (250 kcmil/ph+1/0 awg gnd)	3 - 2.5" (350 kcmil/ph+3/0 awg gnd)
			Bottom	3 - 2.5" (250 kcmil/ph+1/0 awg gnd)	3 - 3" (350 kcmil/ph+3/0 awg gnd)
600	600	480	Top	3 - 2.5" (350 kcmil/ph+2/0 awg gnd)	3 - 3" (500 kcmil/ph+4/0 awg gnd)
			Bottom	3 - 3" (350 kcmil/ph+2/0 awg gnd)	3 - 3.5" (500 kcmil/ph+4/0 awg gnd)
625	625	480	Top	3 - 2.5" (350 kcmil/ph+2/0 awg gnd)	3 - 3" (500 kcmil/ph+4/0 awg gnd)
			Bottom	3 - 3" (350 kcmil/ph+2/0 awg gnd)	3 - 3.5" (500 kcmil/ph+4/0 awg gnd)
750	750	480	Top	4 - 2.5" (350 kcmil/ph+3/0 awg gnd)	4 - 3" (500 kcmil/ph+250 kcmil gnd)
			Bottom	4 - 3" (350 kcmil/ph+3/0 awg gnd)	4 - 3.5" (500 kcmil/ph+250 kcmil gnd)
800	800	480	Top	4 - 2.5" (350 kcmil/ph+3/0 awg gnd)	4 - 3" (500 kcmil/ph+250 kcmil gnd)

**Table 5.10 Recommended conduit and cable sizes (continued)**

UPS Rating		Voltage (VAC)	Cable Entry	(# of conduits); size of conduits; # -size of phase cables per conduit; size of cable for ground per conduit	
kVA	kW			Copper Conductors	Aluminum Conductors
1000	1000	480	Bottom	4 - 3" (350 kcmil/ph+3/0 awg gnd)	4 - 3.5" (500 kcmil/ph+250 kcmil gnd)
			Top	4 - 3" (500 kcmil/ph+4/0 awg gnd)	5 - 3" (500 kcmil/ph+350 kcmil gnd)
1100	1100	480	Bottom	4 - 3.5" (500 kcmil/ph+4/0 awg gnd)	5 - 3.5" (500 kcmil/ph+350 kcmil gnd)
			Top	5 - 3" (500 kcmil/ph+4/0 awg gnd)	6 - 3" (500 kcmil/ph+350 kcmil gnd)
1200	1200	480	Bottom	5 - 3.5" (500 kcmil/ph+4/0 awg gnd)	5 - 4" (600 kcmil/ph+350 kcmil gnd)
			Top	6 - 3" (500 kcmil/ph+250 kcmil gnd)	7 - 3" (500 kcmil/ph+400 kcmil gnd)
			Bottom	5 - 3.5" (600 kcmil/ph+250 kcmil gnd)	6 - 4" (600 kcmil/ph+400 kcmil gnd)
			Top		
<b>BYPASS INPUT</b>					
400	400	415	Top	2 - 3.5" (500 kcmil/ph+2x500 kcmil ntrl+1 awg gnd)	3 - 3" (350 kcmil/ph+2x350 kcmil ntrl+2/0 awg gnd)
			Bottom	2 - 4" (500 kcmil/ph+2x500 kcmil ntrl+1 awg gnd)	3 - 3.5" (350 kcmil/ph+2x350 kcmil ntrl+2/0 awg gnd)
500	500	415	Top	3 - 3" (350 kcmil/ph+2x350 kcmil+1/0 awg gnd)	4 - 3" (350 kcmil/ph+2x350 kcmil ntrl+3/0 awg gnd)
			Bottom	3 - 3.5" (350 kcmil/ph+2x350 kcmil+1/0 awg gnd)	4 - 3.5" (350 kcmil/ph+2x350 kcmil ntrl+3/0 awg gnd)
250	250	480	Top	1 - 3" (500kcmil/ph+3 awg gnd)	2 - 2" (4/0 awg/ph+1 awg gnd)
			Bottom	1 - 3" (500kcmil/ph+3 awg gnd)	2 - 2.5" (4/0 awg/ph+1 awg gnd)
300	300	480	Top	2 - 2" (4/0 awg/ph+3 awg gnd)	2 - 2.5" (250kcmil/ph+1 awg gnd)
			Bottom	2 - 2.5" (4/0 awg/ph+3 awg gnd)	2 - 2.5" (250kcmil/ph+1 awg gnd)
400	400	480	Top	2 - 2.5" (250kcmil/ph+2 awg gnd)	2 - 2.5" (350kcmil/ph+1/0 awg gnd)
			Bottom	2 - 2.5" (250kcmil/ph+2 awg gnd)	2 - 3" (350kcmil/ph+1/0 awg gnd)
500	500	480	Top	3 - 2.5" (250 kcmil/ph+1/0 awg gnd)	3 - 2.5" (350 kcmil/ph+3/0 awg gnd)
			Bottom	3 - 2.5" (250 kcmil/ph+1/0 awg gnd)	3 - 3" (350 kcmil/ph+3/0 awg gnd)

Table 5.10 Recommended conduit and cable sizes (continued)

UPS Rating		Voltage (VAC)	Cable Entry	(# of conduits); size of conduits; # -size of phase cables per conduit; size of cable for ground per conduit	
kVA	kW			Copper Conductors	Aluminum Conductors
600	600	480	Top	3 - 2.5" (350 kcmil/ph+1/0 awg gnd)	3 - 3" (500 kcmil/ph+3/0 awg gnd)
			Bottom	3 - 3" (350 kcmil/ph+1/0 awg gnd)	3 - 3.5" (500 kcmil/ph+3/0 awg gnd)
625	625	480	Top	3 - 2.5" (350 kcmil/ph+1/0 awg gnd)	3 - 3" (500 kcmil/ph+3/0 awg gnd)
			Bottom	3 - 3" (350 kcmil/ph+1/0 awg gnd)	3 - 3.5" (500 kcmil/ph+3/0 awg gnd)
750	750	480	Top	3 - 3" (500 kcmil/ph+2/0 awg gnd)	3 - 3" (600 kcmil/ph+4/0 awg gnd)
			Bottom	3 - 3.5" (500 kcmil/ph+2/0 awg gnd)	3 - 3.5" (600 kcmil/ph+4/0 awg gnd)
800	800	480	Top	3 - 3" (500 kcmil/ph+2/0 awg gnd)	3 - 3" (600 kcmil/ph+4/0 awg gnd)
			Bottom	3 - 3.5" (500 kcmil/ph+2/0 awg gnd)	3 - 3.5" (600 kcmil/ph+4/0 awg gnd)
1000	1000	480	Top	4 - 3" (500 kcmil/ph+4/0 awg gnd)	5 - 3" (500 kcmil/ph+350 kcmil gnd)
			Bottom	4 - 3.5" (500 kcmil/ph+4/0 awg gnd)	5 - 3.5" (500 kcmil/ph+350 kcmil gnd)
1100	1100	480	Top	4 - 3" (500 kcmil/ph+4/0 awg gnd)	5 - 3" (500 kcmil/ph+350 kcmil gnd)
			Bottom	4 - 3.5" (500 kcmil/ph+4/0 awg gnd)	5 - 3.5" (500 kcmil/ph+350 kcmil gnd)
1200	1200	480	Top	5 - 3" (500 kcmil/ph+4/0 awg gnd)	6 - 3" (500 kcmil/ph+350 kcmil gnd)
			Bottom	5 - 3.5" (500 kcmil/ph+4/0 awg gnd)	5 - 4" (600 kcmil/ph+350 kcmil gnd)
<b>OUTPUT</b>					
400	400	415	Top	2 - 3.5" (500 kcmil/ph+2x500 kcmil ntrl+1 awg gnd)	3 - 3" (350 kcmil/ph+2x350 kcmil ntrl+2/0 awg gnd)
			Bottom	2 - 4" (500 kcmil/ph+2x500 kcmil ntrl+1 awg gnd)	3 - 3.5" (350 kcmil/ph+2x350 kcmil ntrl+2/0 awg gnd)
500	500	415	Top	3 - 3" (350 kcmil/ph+2x350 kcmil+1/0 awg gnd)	4 - 3" (350 kcmil/ph+2x350 kcmil ntrl+3/0 awg gnd)
			Bottom	3 - 3.5" (350 kcmil/ph+2x350 kcmil+1/0 awg gnd)	4 - 3.5" (350 kcmil/ph+2x350 kcmil ntrl+3/0 awg gnd)
250	250	480	Top	1 - 3" (500 kcmil/ph+3 awg gnd)	2 - 2" (4/0 awg/ph+1 awg gnd)

**Table 5.10 Recommended conduit and cable sizes (continued)**

UPS Rating		Voltage (VAC)	Cable Entry	(# of conduits); size of conduits; # -size of phase cables per conduit; size of cable for ground per conduit	
kVA	kW			Copper Conductors	Aluminum Conductors
300	300	480	Bottom	1 - 3" (500kcmil/ph+3 awg gnd)	2 - 2.5" (4/0 awg/ph+1 awg gnd)
			Top	2 - 2" (4/0 awg/ph+3 awg gnd)	2 - 2.5" (250kcmil/ph+1 awg gnd)
400	400	480	Bottom	2 - 2.5" (4/0 awg/ph+3 awg gnd)	2 - 2.5" (250kcmil/ph+1 awg gnd)
			Top	2 - 2.5" (250kcmil/ph+2 awg gnd)	2 - 2.5" (350kcmil/ph+1/0 awg gnd)
500	500	480	Bottom	2 - 2.5" (250kcmil/ph+2 awg gnd)	2 - 3" (350kcmil/ph+1/0 awg gnd)
			Top	3 - 2.5" (250 kcmil/ph+1/0 awg gnd)	3 - 2.5" (350 kcmil/ph+3/0 awg gnd)
600	600	480	Bottom	3 - 2.5" (250 kcmil/ph+1/0 awg gnd)	3 - 3" (350 kcmil/ph+3/0 awg gnd)
			Top	3 - 2.5" (350 kcmil/ph+1/0 awg gnd)	3 - 3" (500 kcmil/ph+3/0 awg gnd)
625	625	480	Bottom	3 - 3" (350 kcmil/ph+1/0 awg gnd)	3 - 3.5" (500 kcmil/ph+3/0 awg gnd)
			Top	3 - 2.5" (350 kcmil/ph+1/0 awg gnd)	3 - 3" (500 kcmil/ph+3/0 awg gnd)
750	750	480	Bottom	3 - 3.5" (500 kcmil/ph+2/0 awg gnd)	3 - 3.5" (600 kcmil/ph+4/0 awg gnd)
			Top	3 - 3" (500 kcmil/ph+2/0 awg gnd)	3 - 3" (600 kcmil/ph+4/0 awg gnd)
800	800	480	Bottom	3 - 3.5" (500 kcmil/ph+2/0 awg gnd)	3 - 3.5" (600 kcmil/ph+4/0 awg gnd)
			Top	3 - 3" (500 kcmil/ph+2/0 awg gnd)	3 - 3" (600 kcmil/ph+4/0 awg gnd)
1000	1000	480	Bottom	4 - 3.5"(500 kcmil/ph+4/0 awg gnd)	5 - 3.5"(500 kcmil/ph+350 kcmil gnd)
			Top	4 - 3"(500 kcmil/ph+4/0 awg gnd)	5 - 3"(500 kcmil/ph+350 kcmil gnd)
1100	1100	480	Bottom	4 - 3.5"(500 kcmil/ph+4/0 awg gnd)	5 - 3.5"(500 kcmil/ph+350 kcmil gnd)
			Top	4 - 3"(500 kcmil/ph+4/0 awg gnd)	5 - 3"(500 kcmil/ph+350 kcmil gnd)
1200	1200	480	Bottom	5 - 3.5" (500 kcmil/ph+4/0 awg gnd)	5 - 4" (600 kcmil/ph+350 kcmil gnd)
			Top	5 - 3" (500 kcmil/ph+4/0 awg gnd)	6 - 3" (500 kcmil/ph+350 kcmil gnd)

Table 5.10 Recommended conduit and cable sizes (continued)

UPS Rating		Voltage (VAC)	Cable Entry	(# of conduits); size of conduits; # -size of phase cables per conduit; size of cable for ground per conduit	
kVA	kW			Copper Conductors	Aluminum Conductors
<b>BATTERY</b>					
400	400	415	Top	3 - 2.5" (600 kcmil/polarity+3/0 awg gnd)	3 - 3" (600kcmil/polarity+3/0 awg gnd)
			Bottom	4 - 2.5" (500 kcmil/polarity+250 kcmil gnd)	4 - 3" (500 kcmil/polarity+ 250 kcmil gnd)
500	500	415	Top	4 - 2.5" (500 kcmil/polarity+4/0 awg gnd)	4 - 3" (500 kcmil/polarity+ 4/0 awg gnd)
			Bottom	5 - 2.5" (500 kcmil/polarity+350 kcmil gnd)	5 - 3" (500 kcmil/polarity+350 kcmil gnd)
250	250	480	Top	2 - 2.5" (500kcmil/polarity+1/0 awg gnd)	3 - 2.5" (350kcmil/polarity+ 3/0 awg gnd)
			Bottom	2 - 3" (500kcmil/polarity+1/0 awg gnd)	3 - 2.5" (350kcmil/polarity+ 3/0 awg gnd)
300	300	480	Top	2 - 2.5" (600kcmil/polarity+1/0 awg gnd)	3 - 2.5" (500kcmil/polarity+ 3/0 awg gnd)
			Bottom	2 - 3" (600kcmil/polarity+1/0 awg gnd)	3 - 3" (500kcmil/polarity+ 3/0 awg gnd)
400	400	480	Top	3 - 2.5" (600kcmil/polarity+3/0 awg gnd)	4 - 2.5" (500kcmil/polarity+ 250kcmil gnd)
			Bottom	3 - 3" (600kcmil/polarity+3/0 awg gnd)	4 - 3" (500kcmil/polarity+ 250kcmil gnd)
500	500	480	Top	4 - 2.5" (500 kcmil/polarity+4/0 awg gnd)	5 - 2.5" (500 kcmil/polarity+350 kcmil gnd)
			Bottom	4 - 3" (500 kcmil/polarity+4/0 awg gnd)	5 - 3" (500 kcmil/polarity+350 kcmil gnd)
600	600	480	Top	4 - 2.5" (600 kcmil/polarity+4/0 awg gnd)	5 - 3" (600 kcmil/polarity+350 kcmil gnd)
			Bottom	4 - 3" (600 kcmil/polarity+4/0 awg gnd)	5 - 3" (600 kcmil/polarity+350 kcmil gnd)

**Table 5.10 Recommended conduit and cable sizes (continued)**

UPS Rating		Voltage (VAC)	Cable Entry	(# of conduits); size of conduits; # -size of phase cables per conduit; size of cable for ground per conduit	
kVA	kW			Copper Conductors	Aluminum Conductors
625	625	480	Top	5 - 3" (600 kcmil/polarity+250 kcmil gnd)	6 - 3" (600 kcmil/polarity+400 kcmil gnd)
			Bottom	5 - 3" (600 kcmil/polarity+250 kcmil gnd)	6 - 3.5" (600 kcmil/polarity+400 kcmil gnd)
750	750	480	Top	5 - 3" (600 kcmil/polarity+250 kcmil gnd)	6 - 3" (600 kcmil/polarity+400 kcmil gnd)
			Bottom	5 - 3" (600 kcmil/polarity+250 kcmil gnd)	6 - 3.5" (600 kcmil/polarity+400 kcmil gnd)
800	800	480	Top	6 - 3" (600 kcmil/polarity+350 kcmil gnd)	7 - 3" (700 kcmil/polarity+600 kcmil gnd)
			Bottom	6 - 3" (600 kcmil/polarity+350 kcmil gnd)	7 - 3.5" (700 kcmil/polarity+600 kcmil gnd)
1000	1000	480	Top	8 - 3" (600 kcmil/polarity+500 kcmil gnd)	8 - 3" (700 kcmil/polarity+600 kcmil gnd)
			Bottom	8 - 3.5" (600 kcmil/polarity+500 kcmil gnd)	8 - 3.5" (700 kcmil/polarity+600 kcmil gnd)
1100	1100	480	Top	8 - 3" (600 kcmil/polarity+500 kcmil gnd)	8 - 3" (700 kcmil/polarity+600 kcmil gnd)
			Bottom	8 - 3.5" (600 kcmil/polarity+500 kcmil gnd)	8 - 3.5" (700 kcmil/polarity+600 kcmil gnd)



**Table 5.10 Recommended conduit and cable sizes (continued)**

UPS Rating		Voltage (VAC)	Cable Entry	(# of conduits); size of conduits; # -size of phase cables per conduit; size of cable for ground per conduit	
kVA	kW			Copper Conductors	Aluminum Conductors
1200	1200	480	Top	9 - 3"(750 kcmil/polarity+500 kcmil gnd)	11 - 3"(700 kcmil/polarity+750 kcmil gnd)
			Bottom	10 - 3.5"(600 kcmil/polarity+500 kcmil gnd)	11 - 3.5"(700 kcmil/polarity+750 kcmil gnd)
<ol style="list-style-type: none"> <li>Recommended cable sizes are 167°F (75°C) (THW) wire at 86°F (30°C) ambient.</li> <li>Refer to NEC recommendations for 104°F (40°C) ambient rated conductors.</li> <li>Unless otherwise noted, use copper or aluminum conductors suitable for at least 75°C.</li> <li>Recommended cables and conduits are based on breaker trip setting sized for the maximum continuous rated current for the rectifier input and the nominal current for the bypass and output listed in <b>on the previous page</b>, through <b>on the previous page</b>.</li> <li>Conduit size is based on RNC type conduit for bottom input and EMT-type conduit for top input.</li> <li>Vertiv™ recommends that the site planner choose the appropriate cable type based on the particular installation requirements.</li> <li>These recommendations are for use with 100% rated breakers. For 125% rated breakers, refer to the NEC recommended conduit and cable sizes.</li> <li>Upstream and downstream non-standard recommended breaker settings have their trip adjustment behind a suitable cover in accordance with 240.6 (c) of the NEC.</li> </ol>					

**Table 5.11 Recommended Lug Sizes**

Cable Size	T&B Copper One Hole	T&B Copper Two Hole	T&B Aluminum One Hole	T&B Aluminum Two Hole
#8AWG	54930BE	54850BE	60104-TB	—
#6AWG	54905BE	256-30695-868	60109-TB	—
#4AWG	54906BE	256-30695-733	60114-TB	—
#2-3AWG	54942BE	54811BE	60120	—
#1AWG	54947BE	54857BE	60126	—
#1/0AWG	54950BE	256-30695-593	60132	—
#2/0AWG	54951BE	54862BE	60138	60238
#3/0AWG	54965BE	54864BE	60144	60244
#4/0AWG	54970BE	54866BE	60150	60250
250kcmil	54913BE	54868BE	60156	60256
300kcmil	54914BE	54870BE	60162	60262
350kcmil	54915BE	54872BE	60165	60267
400kcmil	54916BE	54874BE	60168	60269
500kcmil	54918BE	54876BE	60171	60273
600kcmil	54920BE	54878BE	60176	60275
750kcmil	54922BE	54880BE	60178	60277

**Table 5.12 Recommended Torque Values**

Grade 5 Steel: Unified Thread System Torque, lbf.*in.				Class 8.8 Steel: Metric Thread System Torque, N*m			
Fastener Finish		Plain Steel	Zinc Plating	Fastener Finish		Plain Steel	Zinc Plating
Size	Threads/ Inch, Tpi	No Washer/ Flat Washer	No Washer/ Flat Washer	Size	Thread Pitch, Tp	No Washer/Flat Washer	No Washer/Flat Washer
1/4	20	101	91	M5	0.8	6.1	5.5
	28	116	104		0.5	6.9	6.2
5/16	18	209	188	M6	1	10	9
	24	231	208		0.75	11	10
3/8	16	370	333	M8	1.25	25	23
	24	420	378		1	27	24
7/16	14	593	534	M10	1.5	50	45
	20	662	596		1.25	53	47
1/2	13	904	814	M12	1.75	87	78
	20	1020	918		1.25	95	86
9/16	12	1305	1175	M14	2	139	125
	18	1456	1310		1.5	151	136

**Table 5.13 Components required for seismic configuration**

Part #	Description
EXLS1OSH400S	Seismic Anchor Kit, EXL S1 250-400kVA 480 V UPS w/ Standard IO Cabinet
EXLS1OSH4002	Seismic Anchor Kit, EXL S1 250-400kVA 480 V UPS w/ BFD, Byp Share Inductor IO Cabinet
EXLS1OSH600S	Seismic Anchor Kit, EXL S1 500-600kVA 480 V (400-500kVA 415V) UPS w/ Standard IO Cabinet
EXLS1OSH6002	Seismic Anchor Kit, EXL S1 500-600kVA 480 V (400-500kVA 415V) UPS w/ BFD, Byp Share Inductor IO Cabinet
EXLS1OSH800S	Seismic Anchor Kit, EXL S1 625-800kVA UPS w/ Standard IO Cabinet
EXLS1OSH8002	Seismic Anchor Kit, EXL S1 625-800kVA UPS w/ BFD, CMC, Byp Share Inductor IO Cabinet
EXLS1OSH1200S	Seismic Anchor Kit, EXL S1 1000-1200kVA UPS w/ Standard IO Cabinet
EXLS1OSH12002	Seismic Anchor Kit, EXL S1 1000-1200kVA UPS w/ BFD, CMC, Byp Share Inductor IO Cabinet

# Appendices

## Appendix A: Technical Illustrations

The technical illustrations are in the order of the drawing part number. **Table A.1** below, groups the drawings by referenced topic/application.

**Table A.1 Technical-illustrations Contents**

Drawing Number	UPS model
<b>400 – 500 kVA, 415-V UPS Installation Drawings</b>	
ES1-05-S021	SMS and 1+N multi-module unit
ES1-05-S022	SMS and 1+N multi-module unit with back-feed disconnect
ES1-05-S023	SMS and 1+N multi-module unit with sharing inductors
ES1-05-S024	SMS and 1+N multi-module unit with BFD and sharing inductor
569240P1	Attached battery-system cable-wiring cabinet installation details
<b>250 – 400 kVA, 480-V UPS Installation Drawings</b>	
ES1-05-S025	SMS and 1+N multi-module unit
ES1-05-S026	SMS and 1+N multi-module unit with back-feed disconnect
ES1-05-S027	SMS and 1+N multi-module unit with sharing inductors
ES1-05-S028	SMS and 1+N multi-module unit with BFD and sharing inductor
569240P1	Attached battery-system cable-wiring cabinet installation details
<b>500 – 600 kVA, 480-V UPS Installation Drawings</b>	
ES1-05-S017	SMS and 1+N multi-module unit
ES1-05-S018	SMS and 1+N multi-module unit with back-feed disconnect
ES1-05-S019	SMS and 1+N multi-module unit with sharing inductors
ES1-05-S020	SMS and 1+N multi-module unit with BFD and sharing inductor
569240P1	Attached battery-system cable-wiring cabinet installation details
<b>625 – 800 kVA UPS Installation Drawings</b>	
ES1-05-S009	SMS and 1+N multi-module unit
ES1-05-S010	SMS and 1+N multi-module unit with back-feed disconnect
ES1-05-S011	SMS and 1+N multi-module unit with sharing inductor
ES1-05-S012	SMS and 1+N multi-module unit with BFD and sharing inductor
ES1-05-S013	SMS and 1+N multi-module unit with common mode choke
ES1-05-S014	SMS and 1+N multi-module unit with common mode choke and BFD
ES1-05-S015	SMS and 1+N multi-module unit with common mode choke and sharing inductor
ES1-05-S016	SMS and 1+N multi-module unit with common mode choke, BFD, and sharing inductor

**Table A.1 Technical-illustrations Contents (continued)**

<b>Drawing Number</b>	<b>UPS model</b>
<b>1000 – 1200 kVA UPS Installation Drawings</b>	
ES1-05-S001	SMS and 1+N multi-module unit
ES1-05-S002	SMS and 1+N multi-module unit with optional back-feed disconnect
ES1-05-S003	SMS and 1+N multi-module unit with sharing inductor
ES1-05-S004	SMS and 1+N multi-module unit with optional back-feed disconnect and sharing inductor
559322P1	Interconnection Details for 1000 – 1200 kVA models without common mode choke
ES1-05-S005	SMS, 1+N, and N+1 multi-module unit with common mode choke
ES1-05-S006	SMS, 1+N, and N+1 multi-module unit with common mode choke and BFD
ES1-05-S007	SMS, 1+N, and N+1 multi-module unit with common mode choke and sharing inductor
ES1-05-S008	SMS, 1+N, and N+1 multi-module unit with common mode choke, BFD, and sharing inductor
<b>Connection Points and Shipping Splits</b>	
559322P1	Mechanical installation, 800 and 1200kVA UPS with Input/Output Cabinet 1
561763P1	Mechanical installation, 800 and 1200kVA UPS with Input/Output Cabinet 2 or 3
562059P1	Interconnection Details for models with common mode choke
<b>System Cabling Layouts - Single Module, Single-Input Layouts</b>	
ES1-01-S001	with static bypass
ES1-01-S002	with static bypass and back-feed disconnect
ES1-01-S003	with static bypass and two-breaker external maintenance bypass
ES1-01-S004	with static bypass, two-breaker external maintenance bypass, and back-feed breaker
ES1-01-S005	with single input, static bypass, and three-breaker external maintenance bypass
ES1-01-S006	with static bypass, three-breaker external maintenance bypass, and back-feed disconnect
<b>System Cabling Layouts - Single Module, Dual-Input Layouts</b>	
ES1-01-S007	with static bypass
ES1-01-S008	with static bypass and back-feed disconnect
ES1-01-S009	with static bypass and two-breaker external maintenance bypass
ES1-01-S010	with static bypass, two-breaker external maintenance bypass, and back-feed disconnect
ES1-01-S011	with static bypass and three-breaker external maintenance bypass
ES1-01-S012	with static bypass and four-breaker external maintenance bypass
<b>System Cabling Layouts - 1+N Multi-Module, Single-Input Layouts</b>	
ES1-02-S001	with static bypass and two-breaker paralleling cabinet
ES1-02-S002	with static bypass, two-breaker paralleling cabinet, and back-feed disconnect
ES1-02-S005	without static bypass
<b>System Cabling Layouts - 1+N Multi-Module, Dual-Input Layouts</b>	
ES1-02-S003	with static bypass and two-breaker paralleling cabinet

**Table A.1 Technical-illustrations Contents (continued)**

Drawing Number	UPS model
ES1-02-S004	with static bypass, two-breaker paralleling cabinet, and back-feed disconnect
<b>System Cabling Layouts - Control Cabling Layouts</b>	
ES1-19-S002	Control wiring
ES1-19-S003	DC source cable layout - UPS with matching battery cabinets
ES1-19-S004	DC source cable layout - UPS with third-party battery cabinets
ES1-19-S005	DC source cable layout - UPS with third-party maintenance-bypass-distribution and battery cabinets
ES1-19-S007	Maintenance bypass cabinet with single module
ES1-19-S024	System controls, distributed static switch (1+N) multi-module and paralleling cabinet

NOTES

1. ALL DIMENSIONS ARE IN inches [mm].
2. 24" [610mm] MINIMUM CLEARANCE ABOVE UNIT REQUIRED FOR AIR EXHAUST. 50" [1270mm] FRONT ACCESS IS REQUIRED FOR SERVICE.
3. KEEP CABINET WITHIN 15 DEGREES OF VERTICAL.
4. ALL WIRING MUST BE IN ACCORDANCE WITH NATIONAL AND LOCAL ELECTRICAL CODES.
5. UNIT BOTTOM IS STRUCTURALLY ADEQUATE FOR FORKLIFT HANDLING.
6. WIDTH DIMENSIONS INCLUDE SIDE PANELS.

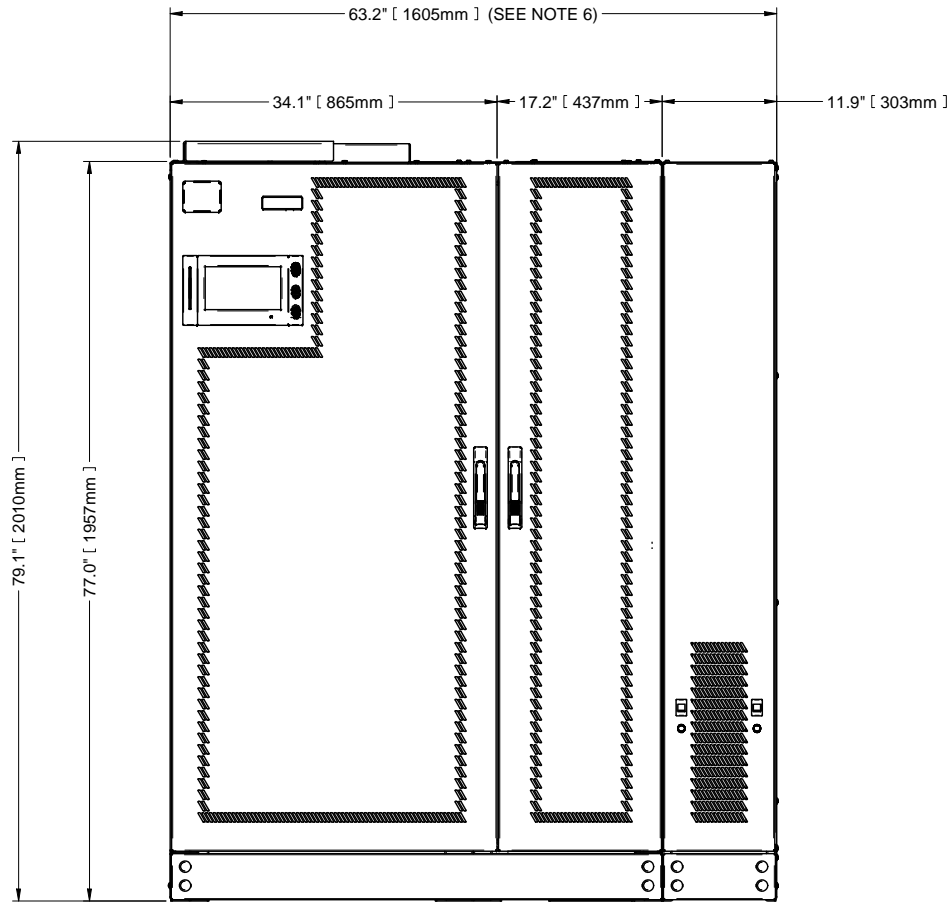

FRONT VIEW

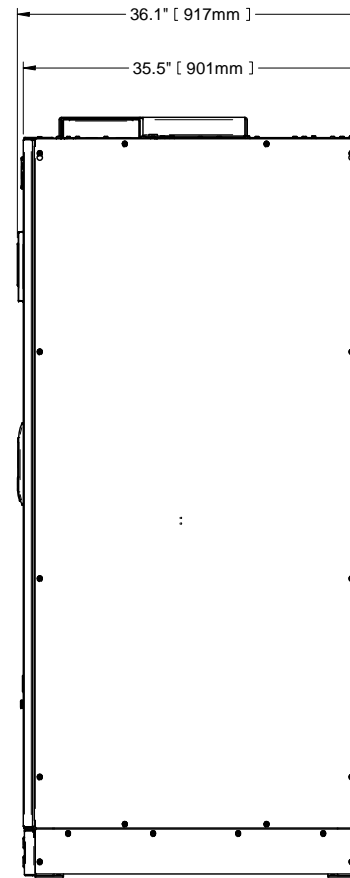

RIGHT SIDE VIEW

SHEET NO. 1 OF 6	DRAWN BY: JASON ZHANG	TITLE  <b>OUTLINE DRAWING</b> <b>SMS AND 1+N MULTI-MODULE, 250kVA-400kVA, 480V</b> <b>WITH BFD AND SHARING INDUCTOR</b> <b>LIEBERT EXL S1</b>
ECN NO.	DESIGNED BY: JASON ZHANG	
REF DWG.	APPROVED BY:	
REF DWG	S. MAJOR	

DWG. NO. ES1-05-S028	1050 DEARBORN DR P.O. BOX 29186 COLUMBUS, OH 43229
DATE (LATEST REV.) 3/19/2020	
REVISION 0	



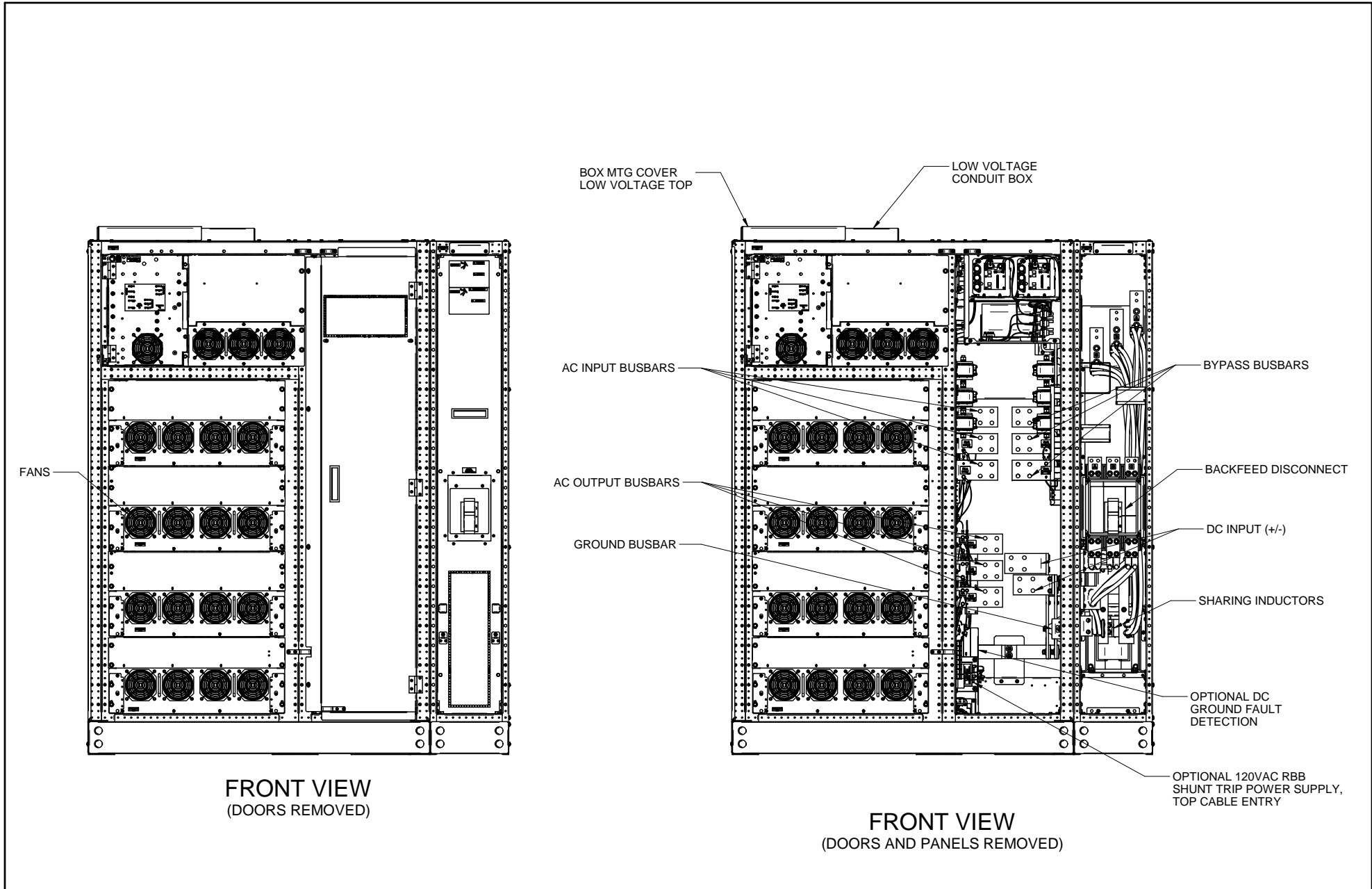

FRONT VIEW  
(DOORS REMOVED)

FRONT VIEW  
(DOORS AND PANELS REMOVED)

SHEET NO. 2 OF 6	DRAWN BY: JASON ZHANG	TITLE
ECN NO.	DESIGNED BY: JASON ZHANG	
REF DWG.	APPROVED BY: S. MAJOR	

MAIN COMPONENTS DRAWING  
SMS AND 1+N MULTI-MODULE, 250kVA-400kVA, 480V  
WITH BFD AND SHARING INDUCTOR  
LIEBERT EXL S1

DWG. NO. ES1-05-S028	DATE (LATEST REV.) 3/19/2020
REVISION 0	1050 DEARBORN DR P.O. BOX 29186 COLUMBUS, OH 43229



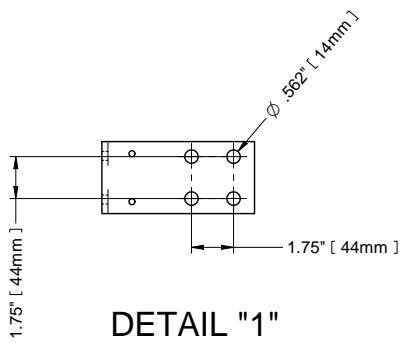

**DETAIL "1"**  
(INPUT/BYPASS BUSBAR)

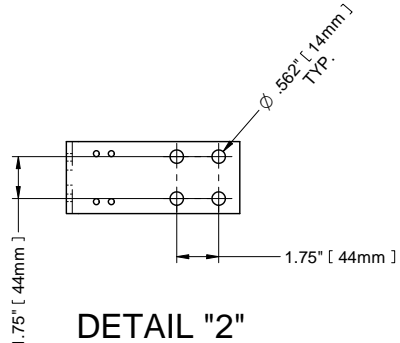

**DETAIL "2"**  
(OUTPUT BUSBAR)

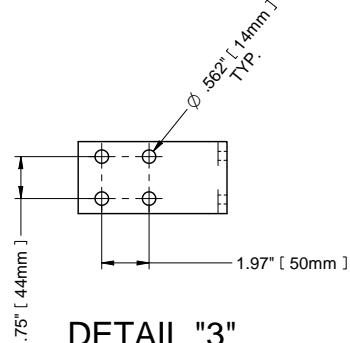

**DETAIL "3"**  
(DC BUSBAR +/-)

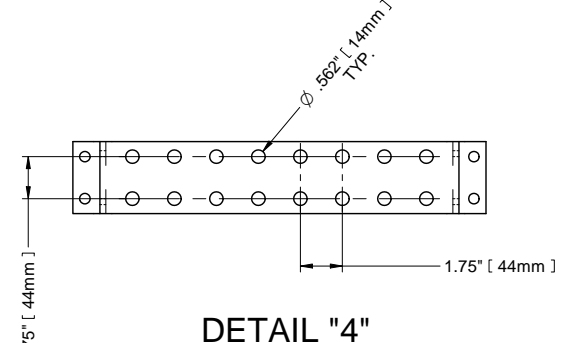

**DETAIL "4"**  
(GROUND BUSBAR)

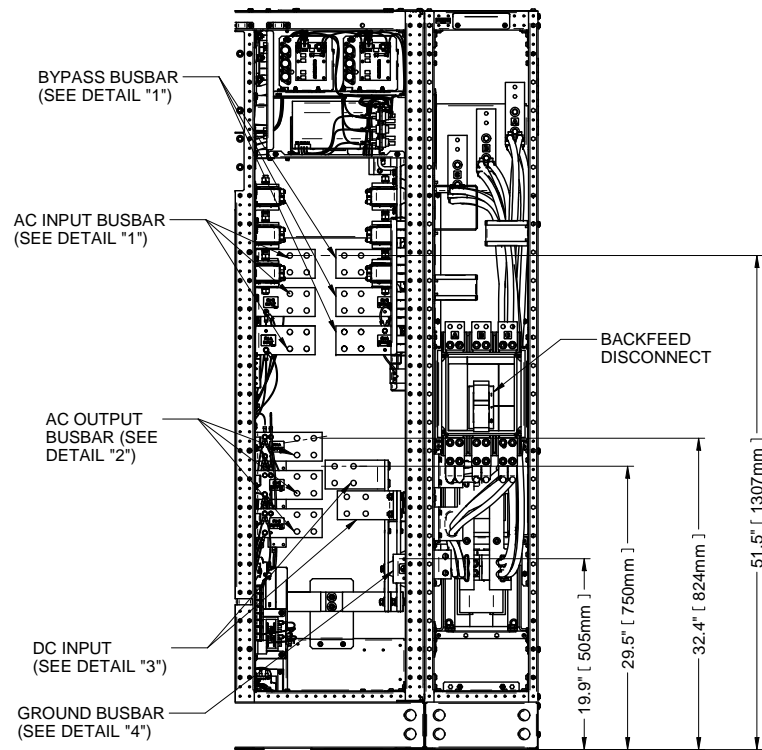

**FRONT VIEW**

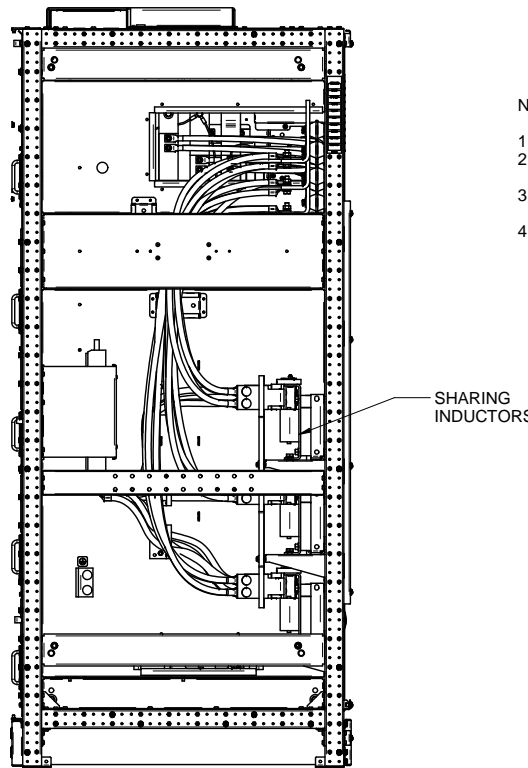

**RIGHT SIDE VIEW**

**NOTES**

1. ALL DIMENSIONS ARE IN inches [mm].
2. CONTROL AND POWER WIRING MUST BE RUN IN SEPARATE CONDUITS.
3. ALL WIRING MUST BE IN ACCORDANCE WITH NATIONAL AND LOCAL ELECTRICAL CODES.
4. COPPER AND ALUMINUM CABLES ARE ACCEPTABLE

SHEET NO. 3 OF 6	DRAWN BY: JASON ZHANG	TITLE
ECN NO.	DESIGNED BY: JASON ZHANG	<b>UPS ELECTRICAL CONNECTION</b> <b>SMS AND 1+N MULTI-MODULE, 250kVA-400kVA, 480V</b> <b>WITH BFD AND SHARING INDUCTOR</b> <b>LIEBERT EXL S1</b>
REF DWG.	APPROVED BY: S. MAJOR	
REF DWG		

DWG. NO. ES1-05-S028
DATE (LATEST REV.) 3/19/2020
REVISION 0
1050 DEARBORN DR P.O. BOX 29186 COLUMBUS, OH 43229





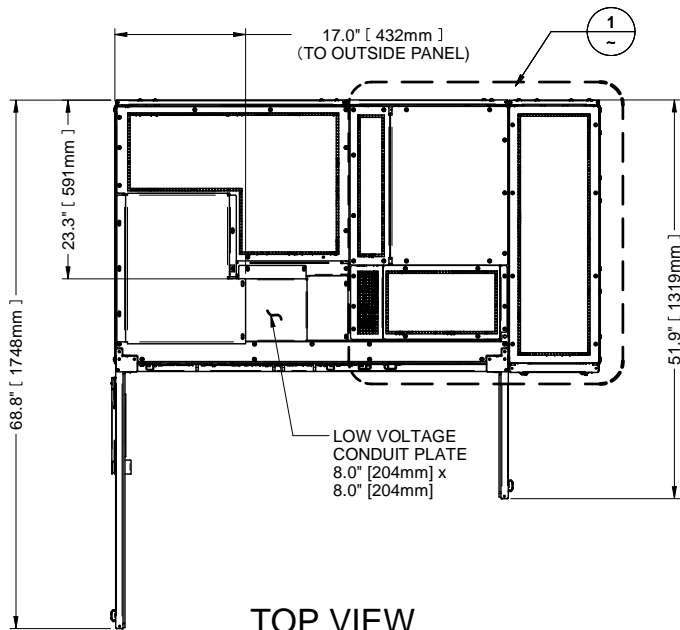

**TOP VIEW**  
(DOORS OPEN)

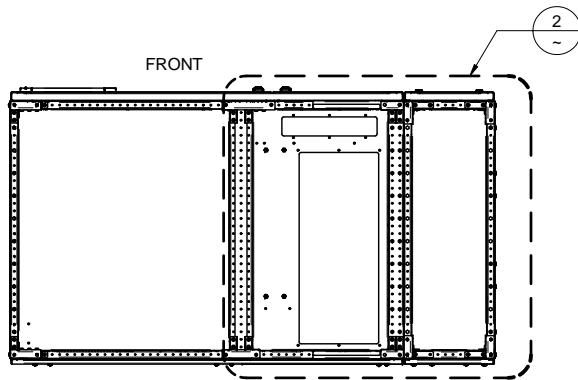

**BOTTOM VIEW**

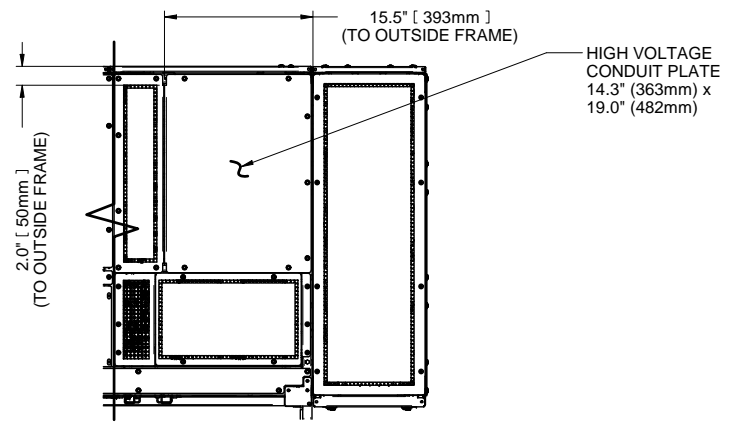

**DETAIL "1"**  
(CABLE ENTRY CONDUIT PLATE)

**NOTES**

1. ALL DIMENSIONS ARE IN inches [mm].
2. UNIT BOTTOM IS STRUCTURALLY ADEQUATE FOR FORKLIFT HANDLING.

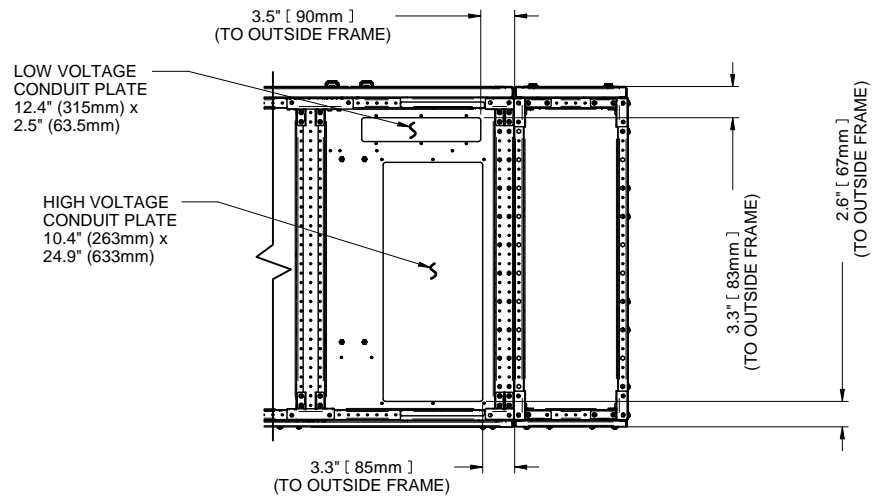

**DETAIL "2"**  
(CABLE ENTRY CONDUIT PLATE)

SHEET NO. 4 OF 6	DRAWN BY: JASON ZHANG	TITLE
ECN NO.	DESIGNED BY: JASON ZHANG	<b>UPS CONDUIT PLATE DETAILS</b> <b>SMS AND 1+N MULTI-MODULE, 250kVA-400kVA, 480V</b> <b>WITH BFD AND SHARING INDUCTOR</b> <b>LIEBERT EXL S1</b>
REF DWG.	APPROVED BY:	
REF DWG	S. MAJOR	

DWG. NO. ES1-05-S028
DATE (LATEST REV.) 3/19/2020
REVISION 0
1050 DEARBORN DR P.O. BOX 29186 COLUMBUS, OH 43229



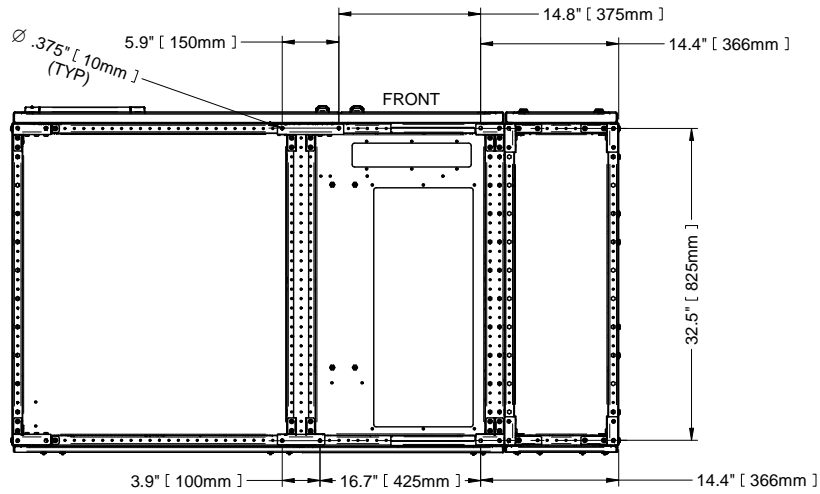

**BOTTOM VIEW**  
(BOLT HOLE LAYOUT)

**NOTES**

1. ALL DIMENSIONS ARE IN inches [mm].
2. UNIT BOTTOM IS STRUCTURALLY ADEQUATE FOR FORKLIFT HANDLING.

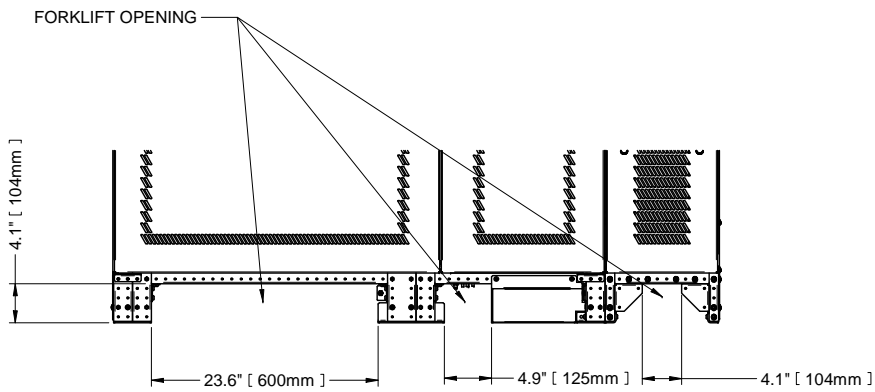

**FRONT VIEW**

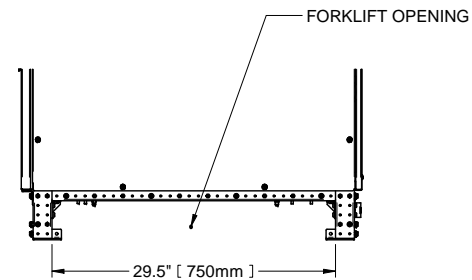

**RIGHT SIDE VIEW**

SHEET NO. 5 OF 6	DRAWN BY: JASON ZHANG	<b>TITLE</b>  UPS BASE DRAWING SMS AND 1+N MULTI-MODULE, 250kVA-400kVA, 480V WITH BFD AND SHARING INDUCTOR LIEBERT EXL S1
ECN NO.	DESIGNED BY: JASON ZHANG	
REF DWG.	APPROVED BY:	
REF DWG	S. MAJOR	

DWG. NO. ES1-05-S028	
DATE (LATEST REV.) 3/19/2020	
REVISION 0	1050 DEARBORN DR P.O. BOX 29186 COLUMBUS, OH 43229

NOTES

1. ALL DIMENSIONS ARE IN inches [mm].

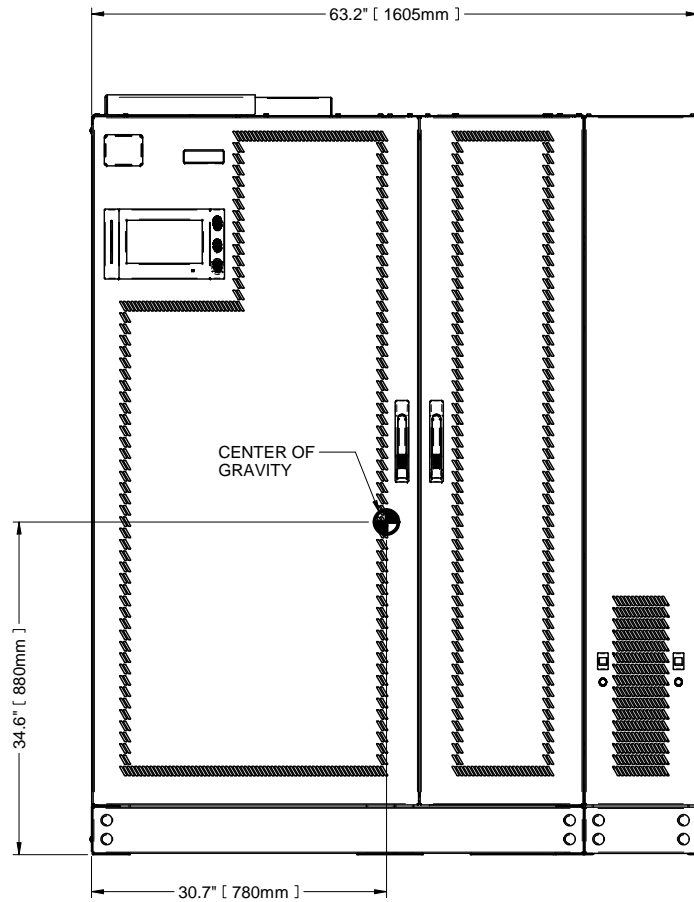

FRONT VIEW

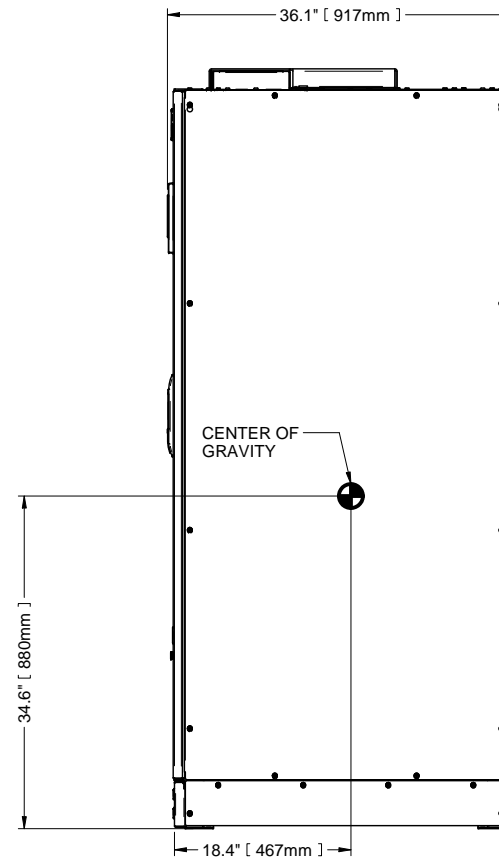

RIGHT SIDE VIEW

SHEET NO. 6 OF 6	DRAWN BY: JASON ZHANG	TITLE  UPS SHIPPING SMS AND 1+N MULTI-MODULE, 250kVA-400kVA, 480V WITH BFD AND SHARING INDUCTOR LIEBERT EXL S1
ECN NO.	DESIGNED BY: JASON ZHANG	
REF DWG.	APPROVED BY:	
REF DWG	S. MAJOR	

DWG. NO. ES1-05-S028	1050 DEARBORN DR P.O. BOX 29186 COLUMBUS, OH 43229
DATE (LATEST REV.) 3/19/2020	
REVISION 0	



NOTES

1. ALL DIMENSIONS ARE IN inches [mm].
2. 24" [610mm] MINIMUM CLEARANCE ABOVE UNIT REQUIRED FOR AIR EXHAUST. 50" [1270mm] FRONT ACCESS IS REQUIRED FOR SERVICE.
3. KEEP CABINET WITHIN 15 DEGREES OF VERTICAL.
4. ALL WIRING MUST BE IN ACCORDANCE WITH NATIONAL AND LOCAL ELECTRICAL CODES.
5. UNIT BOTTOM IS STRUCTURALLY ADEQUATE FOR FORKLIFT HANDLING.
6. WIDTH DIMENSIONS INCLUDE SIDE PANELS.

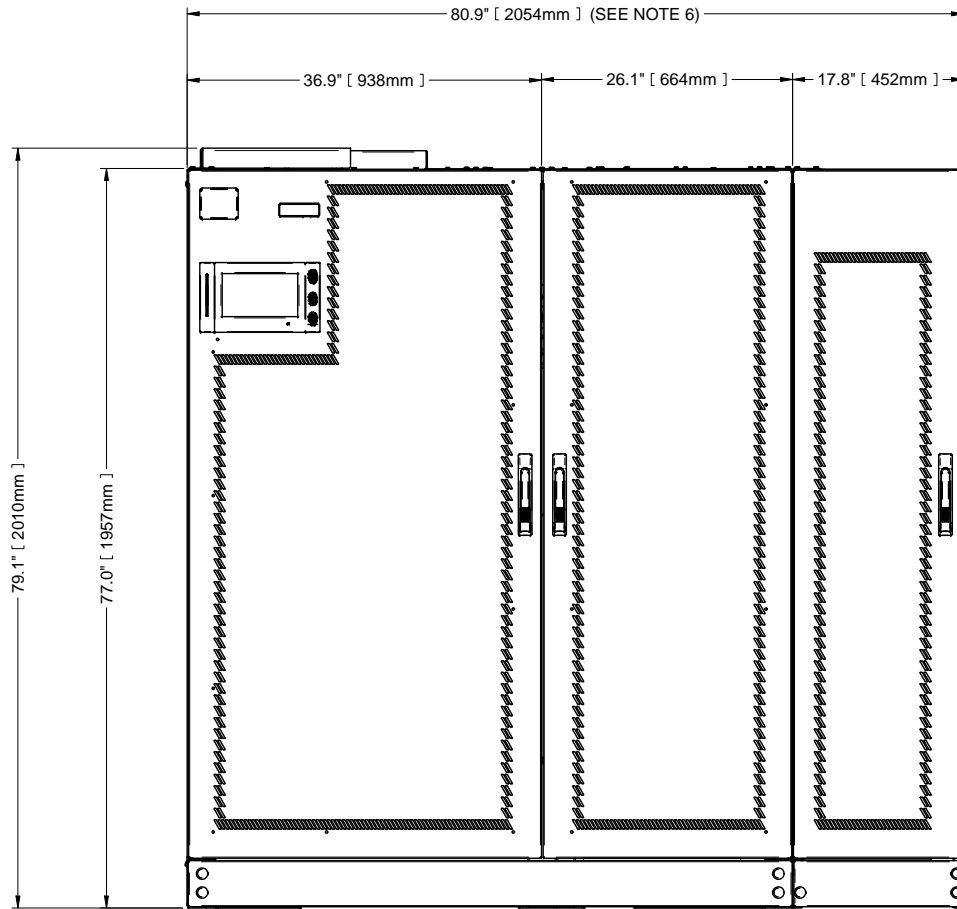

FRONT VIEW

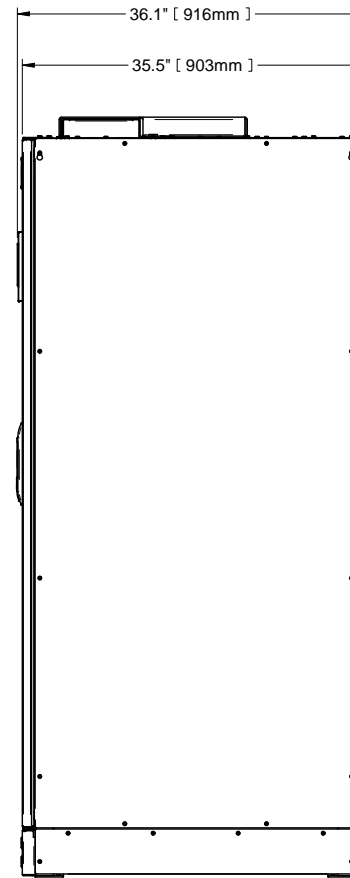

RIGHT SIDE VIEW

SHEET NO. 1 OF 6	DRAWN BY: JASON ZHANG
ECN NO.	DESIGNED BY: JASON ZHANG
REF DWG.	APPROVED BY: S. MAJOR

TITLE	OUTLINE DRAWING
	SMS AND 1+N MULTI-MODULE, 500kVA-600kVA UPS, 480V, WITH COMMON MODE CHOKE
	LIEBERT EXL S1

DWG. NO. ES1-05-S029
DATE (LATEST REV.) 3/19/2020
REVISION 0
1050 DEARBORN DR P.O. BOX 29186 COLUMBUS, OH 43229



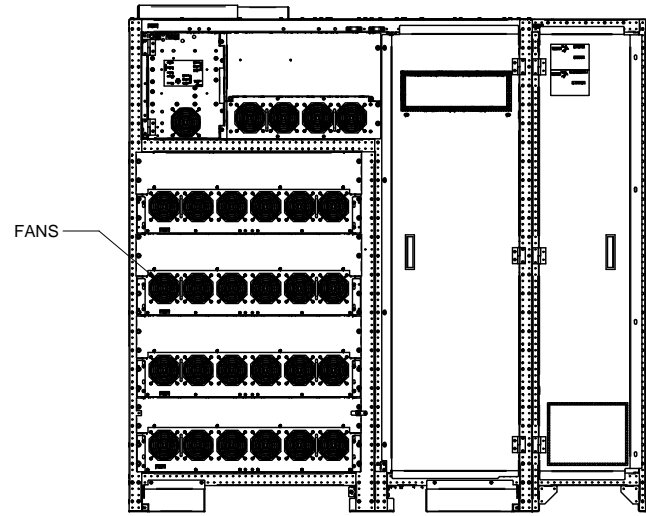

**FRONT VIEW**  
(DOORS REMOVED)

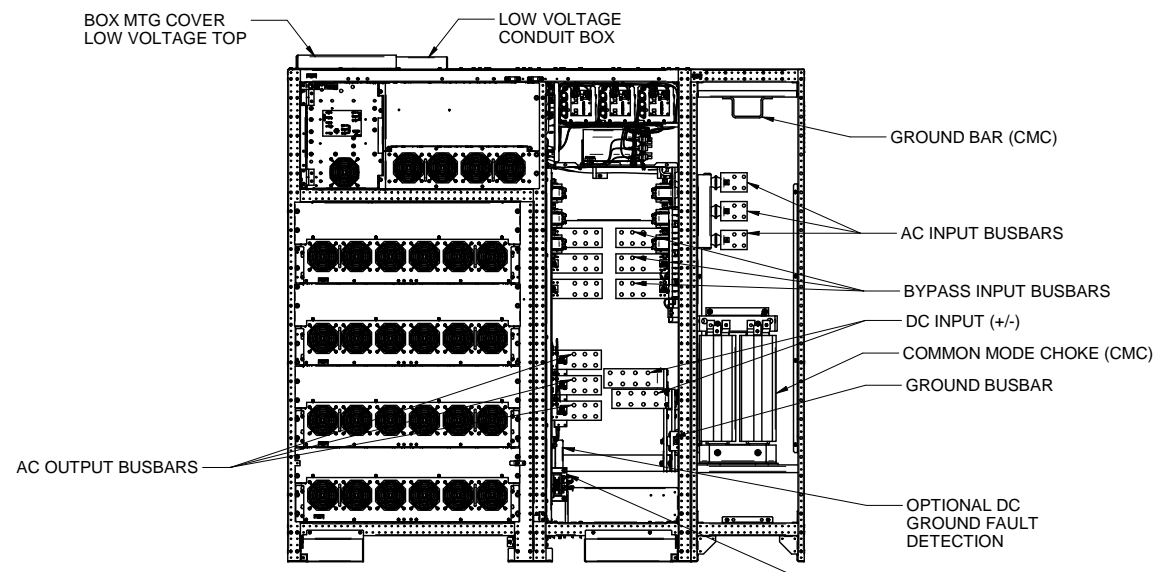

**FRONT VIEW**  
(DOORS AND PANELS REMOVED)

SHEET NO. 2 OF 6	DRAWN BY: JASON ZHANG	<p style="text-align: center;"><b>MAIN COMPONENTS DRAWING</b></p> <p style="text-align: center;"><b>SMS AND 1+N MULTI-MODULE, 500kVA-600kVA UPS, 480V, WITH COMMON MODE CHOKE</b></p> <p style="text-align: center;"><b>LIEBERT EXL S1</b></p>	DWG. NO. ES1-05-S029	
ECN NO.	DESIGNED BY: JASON ZHANG		DATE (LATEST REV.) 3/19/2020	
ECN NO.	APPROVED BY: S. MAJOR		REVISION 0	1050 DEARBORN DR P.O. BOX 29186 COLUMBUS, OH 43229
REF DWG.	REF DWG.			

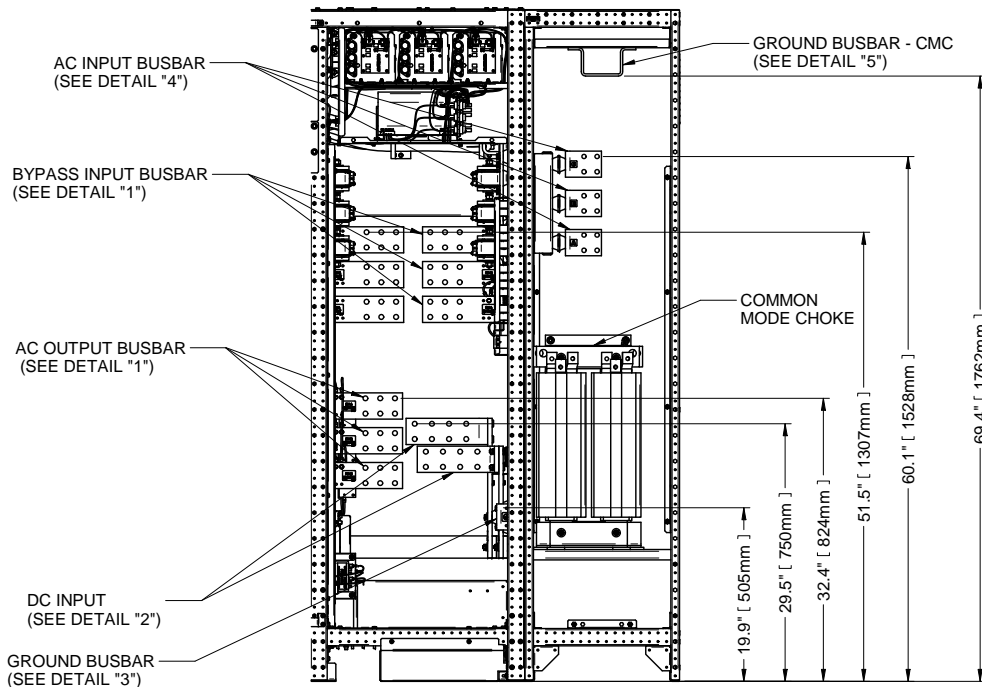
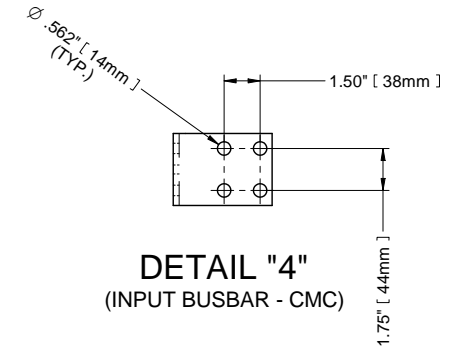
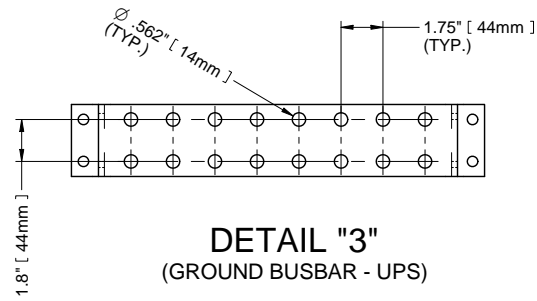
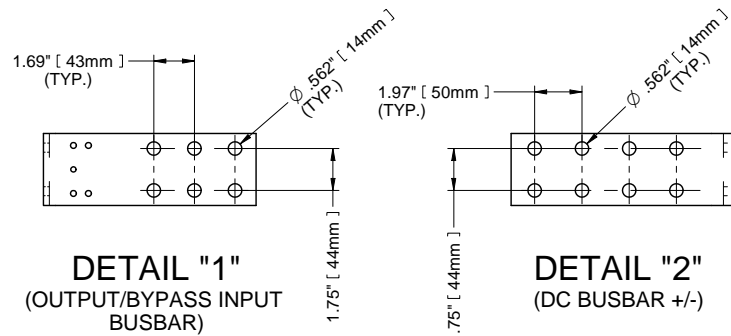

FRONT VIEW

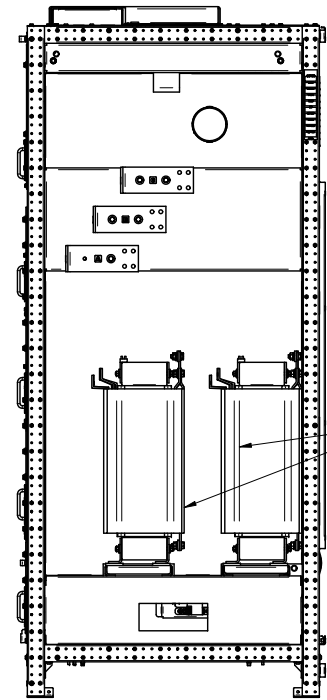

RIGHT SIDE VIEW

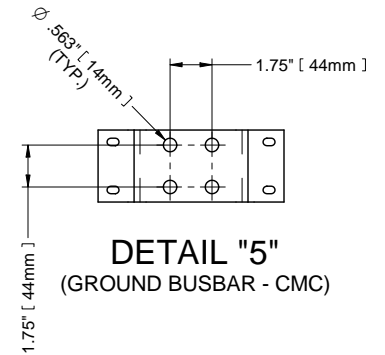

NOTES

1. ALL DIMENSIONS ARE IN inches [mm].
2. CONTROL AND POWER WIRING MUST BE RUN IN SEPARATE CONDUITS.
3. ALL WIRING MUST BE IN ACCORDANCE WITH NATIONAL AND LOCAL ELECTRICAL CODES.
4. COPPER AND ALUMINUM CABLES ARE ACCEPTABLE

SHEET NO. 3 OF 6	DRAWN BY: JASON ZHANG	TITLE <b>UPS ELECTRICAL CONNECTION</b> SMS AND 1+N MULTI-MODULE, 500kVA-600kVA UPS, 480V, WITH COMMON MODE CHOKE <b>LIEBERT EXL S1</b>
ECN NO.	DESIGNED BY: JASON ZHANG	
REF DWG.	APPROVED BY:	
REF DWG	S. MAJOR	

DWG. NO. ES1-05-S029
DATE (LATEST REV.) 3/19/2020
REVISION 0
1050 DEARBORN DR P.O. BOX 29186 COLUMBUS, OH 43229



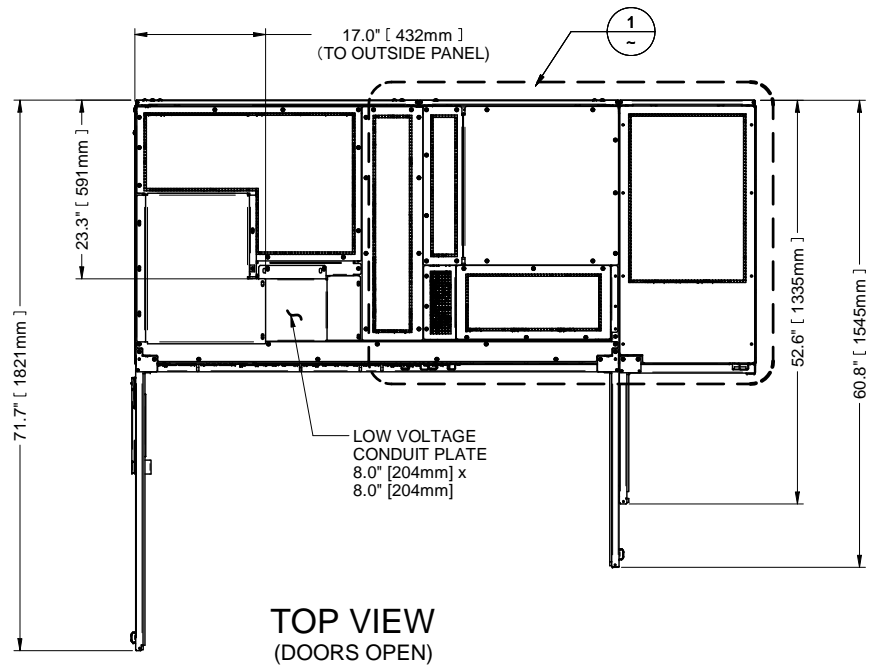

**TOP VIEW**  
(DOORS OPEN)

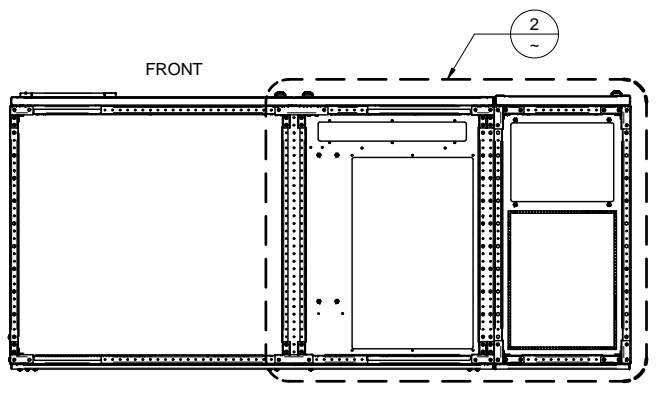

**BOTTOM VIEW**

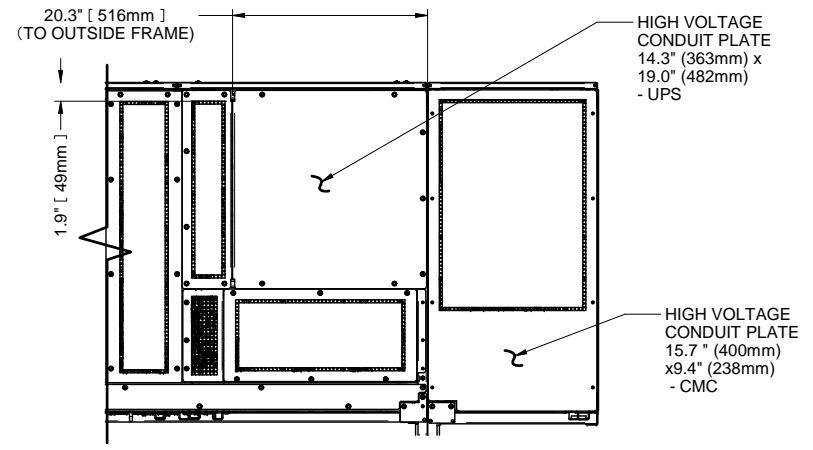

**DETAIL "1"**  
(CABLE ENTRY CONDUIT PLATE)

- NOTES
1. ALL DIMENSIONS ARE IN inches [mm].
  2. UNIT BOTTOM IS STRUCTURALLY ADEQUATE FOR FORKLIFT HANDLING.

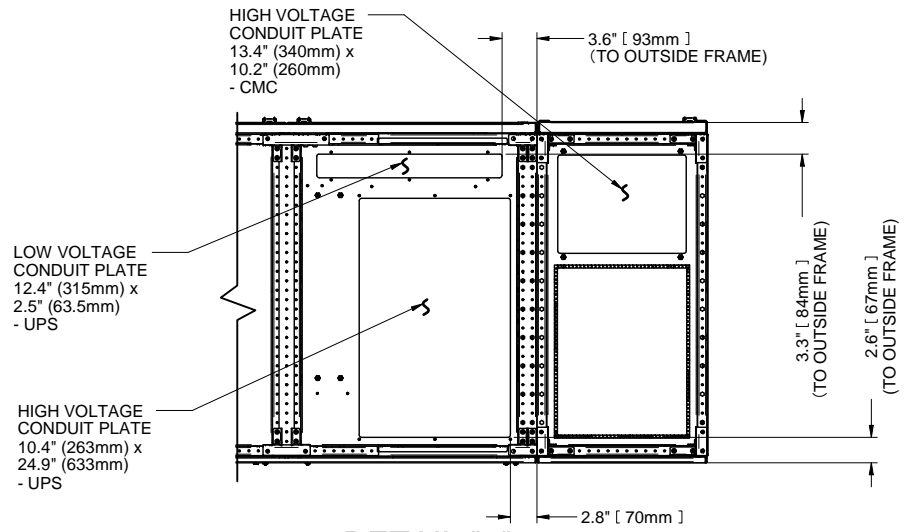

**DETAIL "2"**  
(CABLE ENTRY CONDUIT PLATE)

SHEET NO. 4 OF 6	DRAWN BY: JASON ZHANG	TITLE
ECN NO.	DESIGNED BY: JASON ZHANG	<p align="center"><b>UPS CONDUIT PLATE DETAILS</b></p> <p align="center">SMS AND 1+N MULTI-MODULE, 500kVA-600kVA UPS, 480V, WITH COMMON MODE CHOKE</p> <p align="center">LIEBERT EXL S1</p>
REF DWG.	APPROVED BY:	
REF DWG	S. MAJOR	

DWG. NO. ES1-05-S029
DATE (LATEST REV.) 3/19/2020
REVISION 0
1050 DEARBORN DR P.O. BOX 29186 COLUMBUS, OH 43229



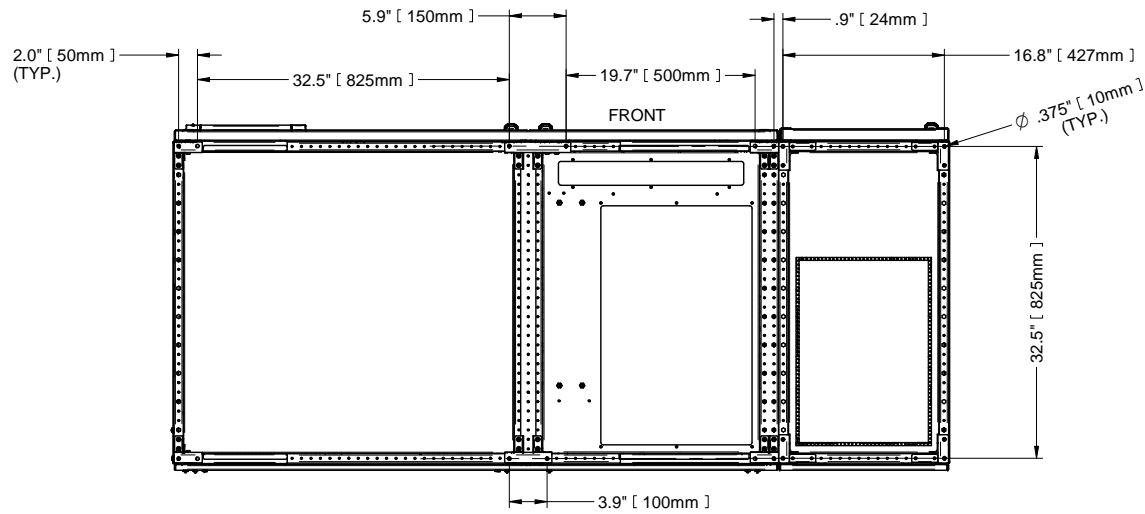

**BOTTOM VIEW**  
(BOLT HOLE LAYOUT)

**NOTES**

1. ALL DIMENSIONS ARE IN inches [mm].
2. UNIT BOTTOM IS STRUCTURALLY ADEQUATE FOR FORKLIFT HANDLING.

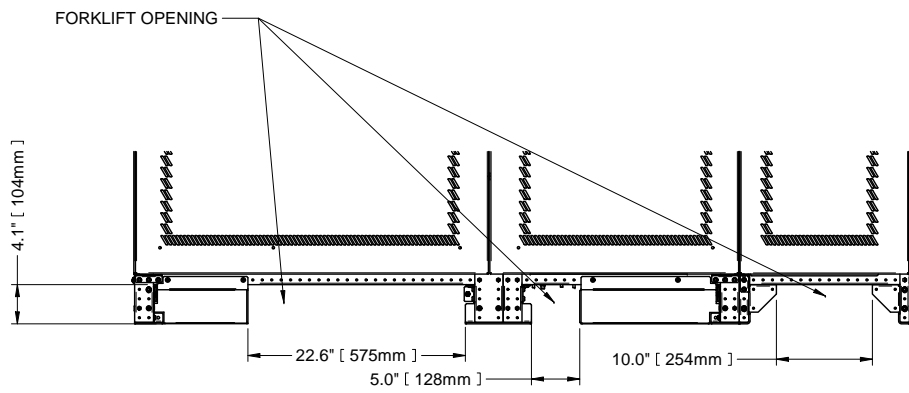

**FRONT VIEW**

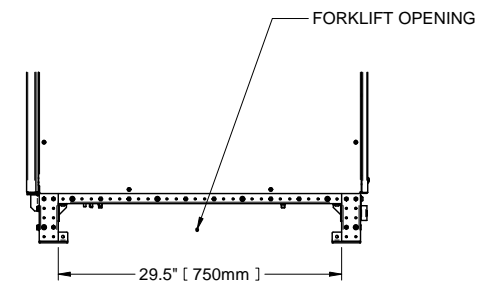

**RIGHT SIDE VIEW**

SHEET NO.	DRAWN BY:	TITLE
5 OF 6	JASON ZHANG	<b>UPS BASE DRAWING</b> <b>SMS AND 1+N MULTI-MODULE, 500kVA-600kVA UPS, 480V,</b> <b>WITH COMMON MODE CHOKE</b> <b>LIEBERT EXL S1</b>
ECN NO.	DESIGNED BY:	
ECN NO	JASON ZHANG	
REF DWG.	APPROVED BY:	
REF DWG	S. MAJOR	

DWG. NO.	ES1-05-S029
DATE (LATEST REV.)	3/19/2020
REVISION	1050 DEARBORN DR P.O. BOX 29186 COLUMBUS, OH 43229
0	





NOTES

1. ALL DIMENSIONS ARE IN inches [mm].

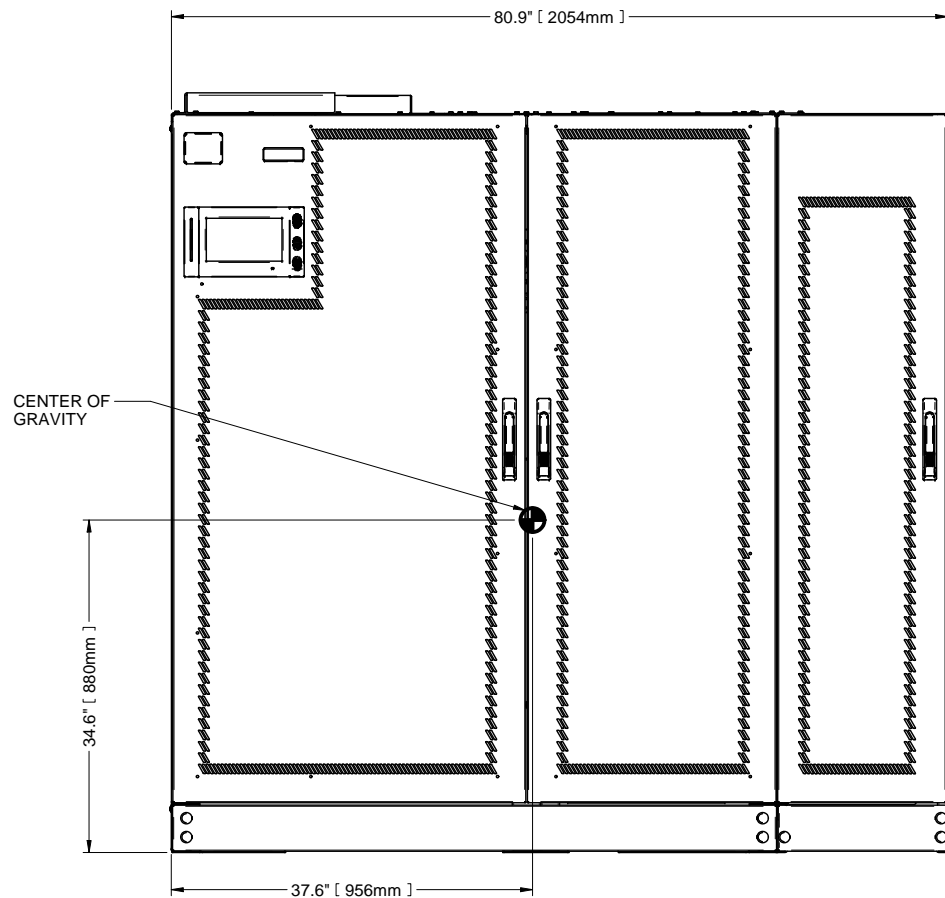

FRONT VIEW

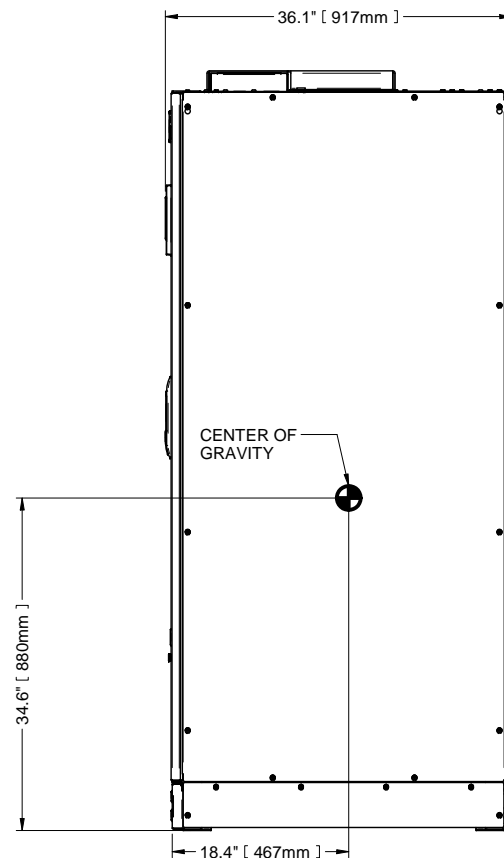

RIGHT SIDE VIEW

SHEET NO. 6 OF 6	DRAWN BY: JASON ZHANG	TITLE  UPS SHIPPING  SMS AND 1+N MULTI-MODULE, 500kVA-600kVA UPS, 480V, WITH COMMON MODE CHOKE  LIEBERT EXL S1
ECN NO.	DESIGNED BY: JASON ZHANG	
ECN NO	JASON ZHANG	
REF DWG. REF DWG	APPROVED BY: S. MAJOR	

DWG. NO. ES1-05-S029	1050 DEARBORN DR P.O. BOX 29186 COLUMBUS, OH 43229
DATE (LATEST REV.) 3/19/2020	
REVISION 0	



- NOTES
1. ALL DIMENSIONS ARE IN inches [mm].
  2. 24" [610mm] MINIMUM CLEARANCE ABOVE UNIT REQUIRED FOR AIR EXHAUST. 50" [1270mm] FRONT ACCESS IS REQUIRED FOR SERVICE.
  3. KEEP CABINET WITHIN 15 DEGREES OF VERTICAL.
  4. ALL WIRING MUST BE IN ACCORDANCE WITH NATIONAL AND LOCAL ELECTRICAL CODES.
  5. UNIT BOTTOM IS STRUCTURALLY ADEQUATE FOR FORKLIFT HANDLING.
  6. WIDTH DIMENSIONS INCLUDE SIDE PANELS.

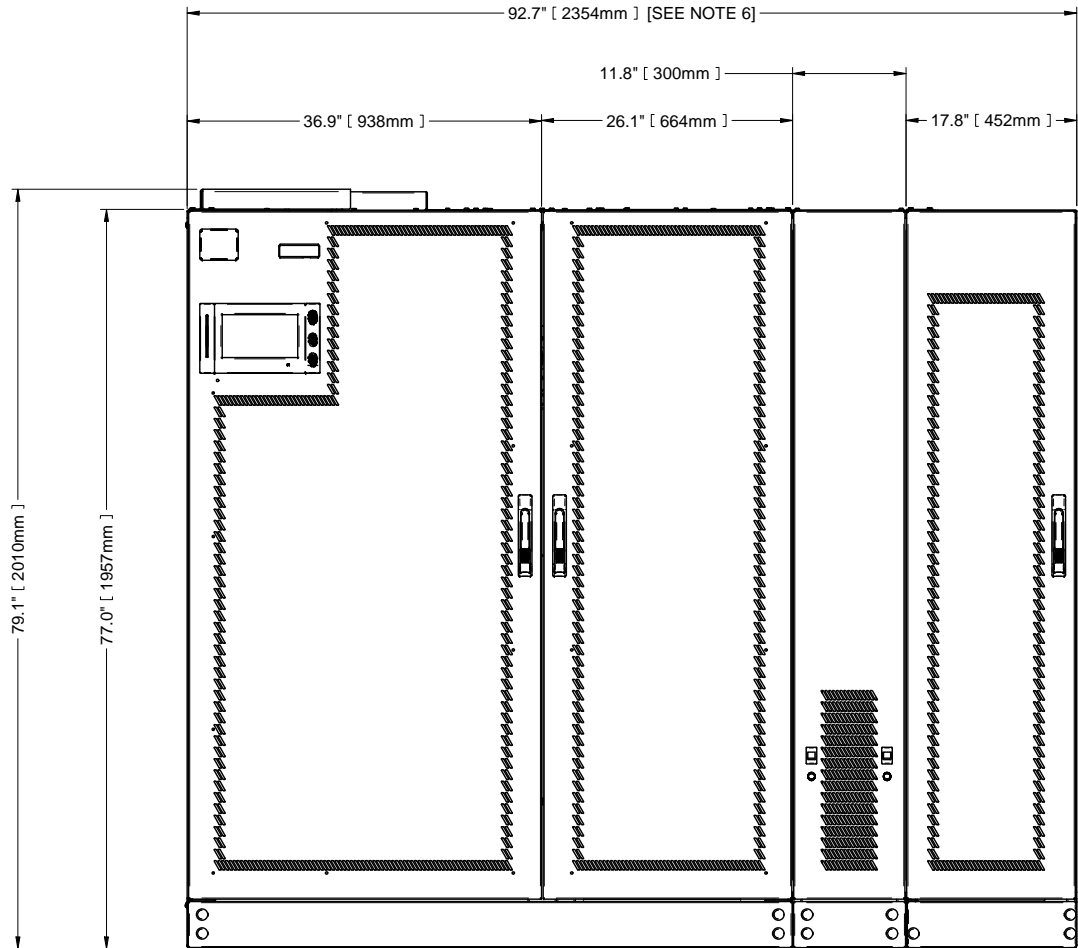

FRONT VIEW

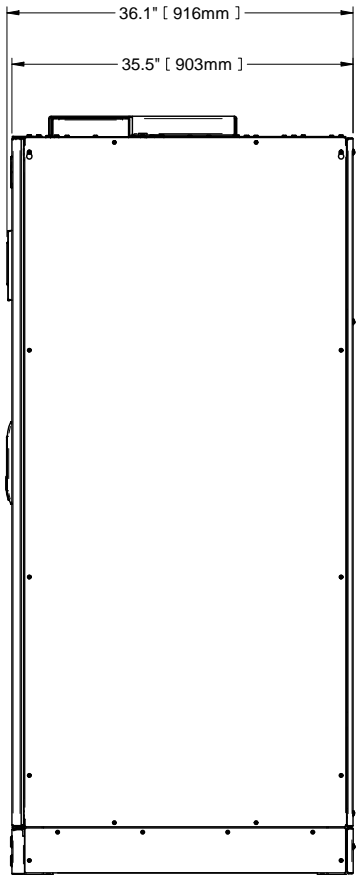

RIGHT SIDE VIEW

SHEET NO. 1 OF 6	DRAWN BY: JASON ZHANG
ECN NO.	DESIGNED BY: JASON ZHANG
REF DWG.	APPROVED BY: S. MAJOR
REF DWG	

TITLE

OUTLINE DRAWING

SMS AND 1+N MULTI-MODULE, 500kVA-600kVA UPS, 480V,  
WITH BFD AND COMMON MODE CHOKE

LIEBERT EXL S1

DWG. NO. ES1-05-S030
DATE (LATEST REV.) 3/19/2020
REVISION 0
1050 DEARBORN DR P.O. BOX 29186 COLUMBUS, OH 43229



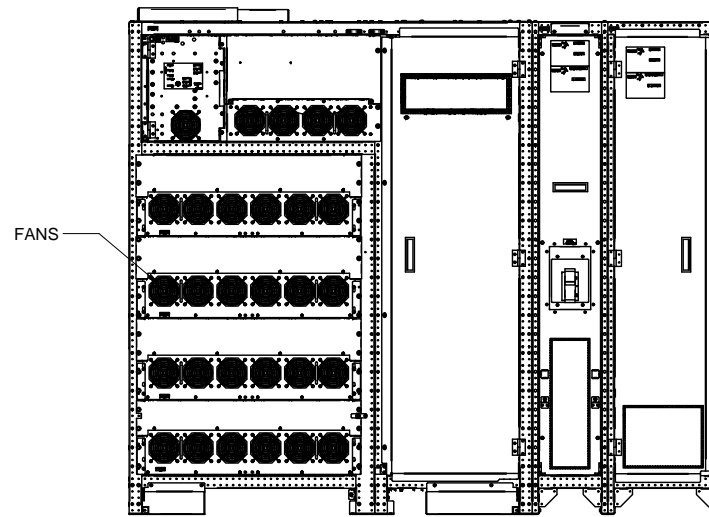

FRONT VIEW  
(DOORS REMOVED)

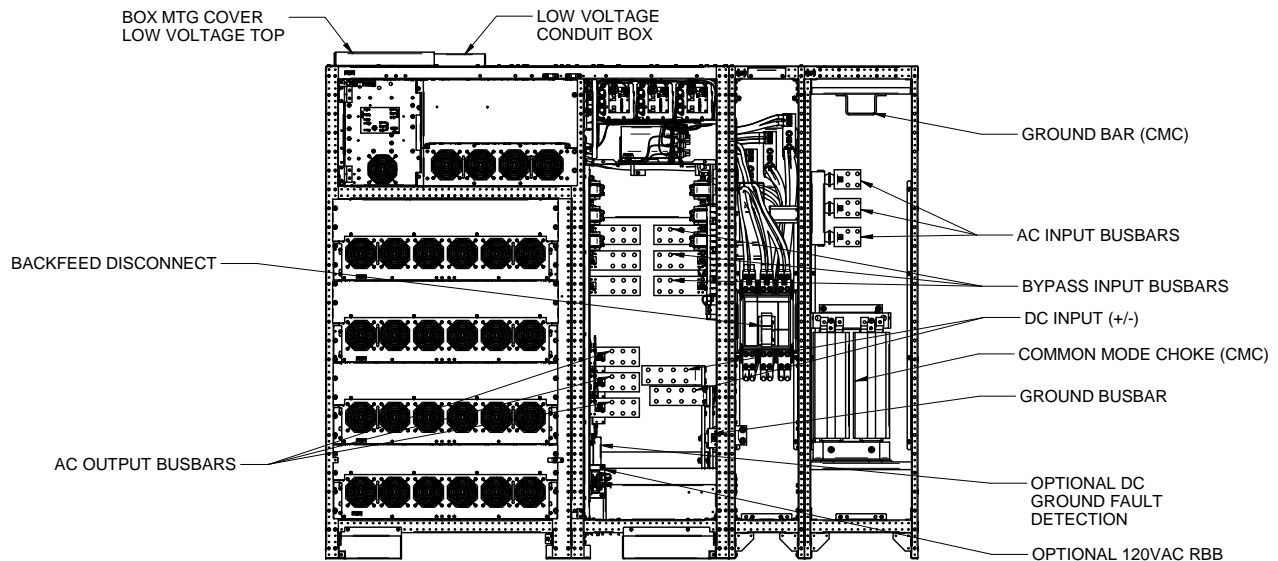

FRONT VIEW  
(DOORS AND PANELS REMOVED)

SHEET NO. 2 OF 6	DRAWN BY: JASON ZHANG	TITLE
ECN NO.	DESIGNED BY: JASON ZHANG	<b>MAIN COMPONENTS DRAWING</b> <b>SMS AND 1+N MULTI-MODULE, 500kVA-600kVA UPS, 480V,</b> <b>WITH BFD AND COMMON MODE CHOKE</b> <b>LIEBERT EXL S1</b>
ECN NO.	JASON ZHANG	
REF DWG.	APPROVED BY: S. MAJOR	
REF DWG	S. MAJOR	

DWG. NO. ES1-05-S030	DATE (LATEST REV.) 3/19/2020
REVISION 0	1050 DEARBORN DR P.O. BOX 29186 COLUMBUS, OH 43229



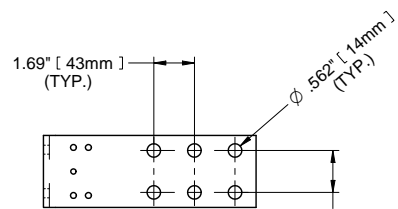

**DETAIL "1"**  
(OUTPUT/BYPASS INPUT  
BUSBAR)

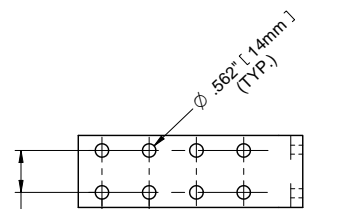

**DETAIL "2"**  
(DC BUSBAR +/-)

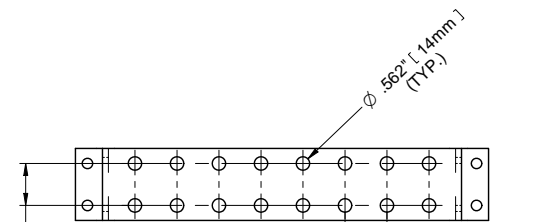

**DETAIL "3"**  
(GROUND BUSBAR - UPS)

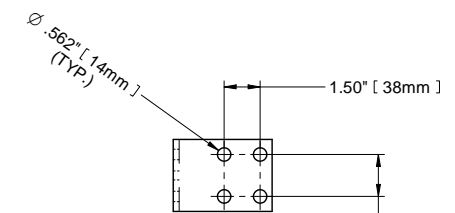

**DETAIL "4"**  
(INPUT BUSBAR - CMC)

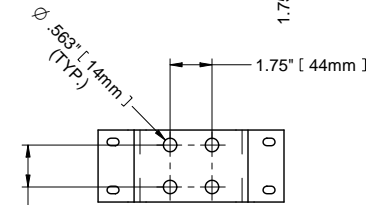

**DETAIL "5"**  
(GROUND BUSBAR - CMC)

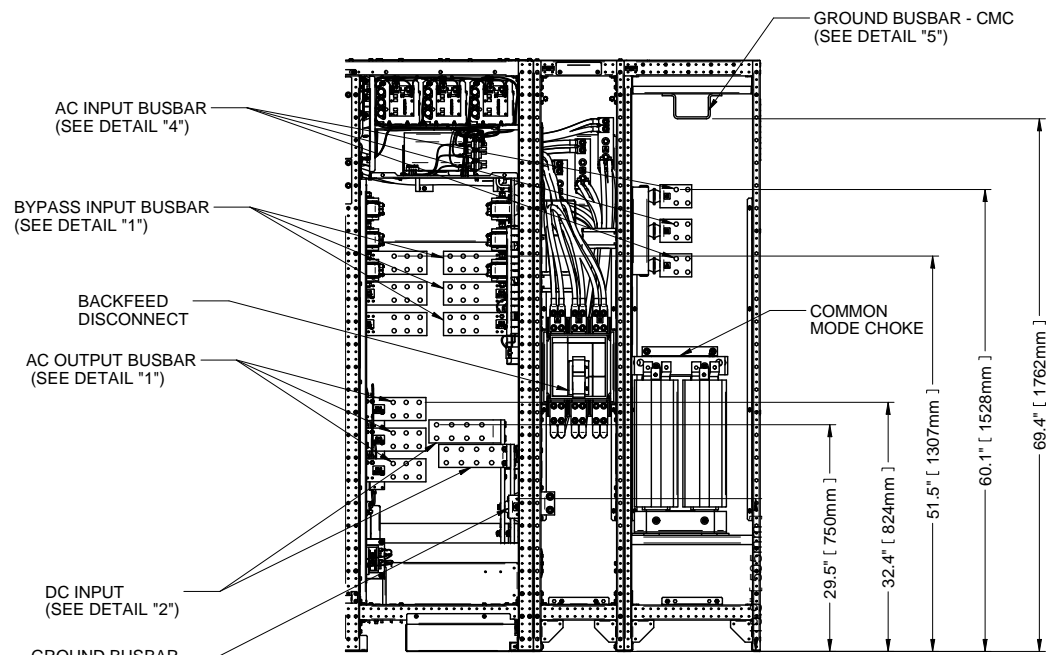

**FRONT VIEW**

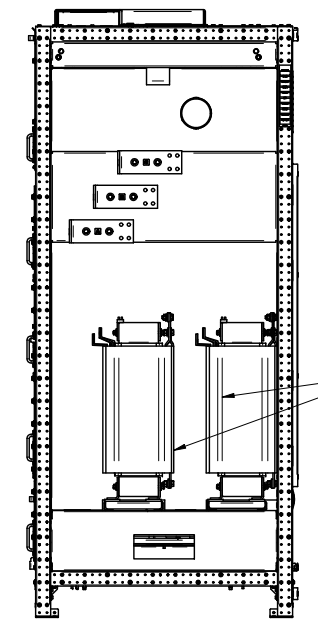

**RIGHT SIDE VIEW**

- NOTES**
1. ALL DIMENSIONS ARE IN inches [mm].
  2. CONTROL AND POWER WIRING MUST BE RUN IN SEPARATE CONDUITS.
  3. ALL WIRING MUST BE IN ACCORDANCE WITH NATIONAL AND LOCAL ELECTRICAL CODES.
  4. COPPER AND ALUMINUM CABLES ARE ACCEPTABLE

SHEET NO. 3 OF 6	DRAWN BY: JASON ZHANG	TITLE
ECN NO.	DESIGNED BY: JASON ZHANG	UPS ELECTRICAL CONNECTION SMS AND 1+N MULTI-MODULE, 500kVA-600kVA UPS, 480V, WITH BFD AND COMMON MODE CHOKE LIEBERT EXL S1
REF DWG.	APPROVED BY: S. MAJOR	

DWG. NO. ES1-05-S030	1050 DEARBORN DR P.O. BOX 29186 COLUMBUS, OH 43229
DATE (LATEST REV.) 3/19/2020	
REVISION 0	



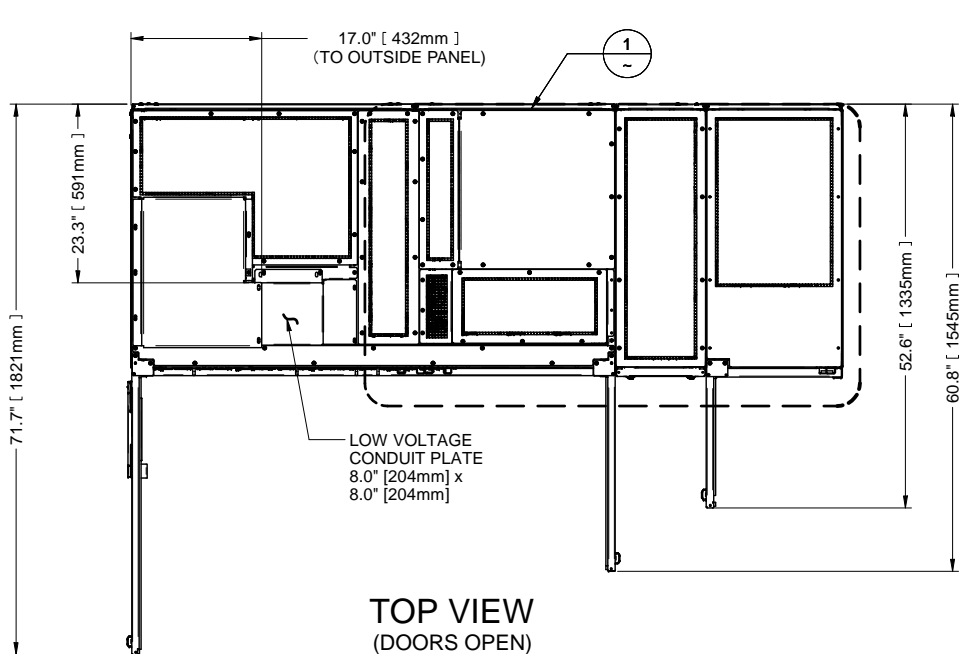

**TOP VIEW**  
(DOORS OPEN)

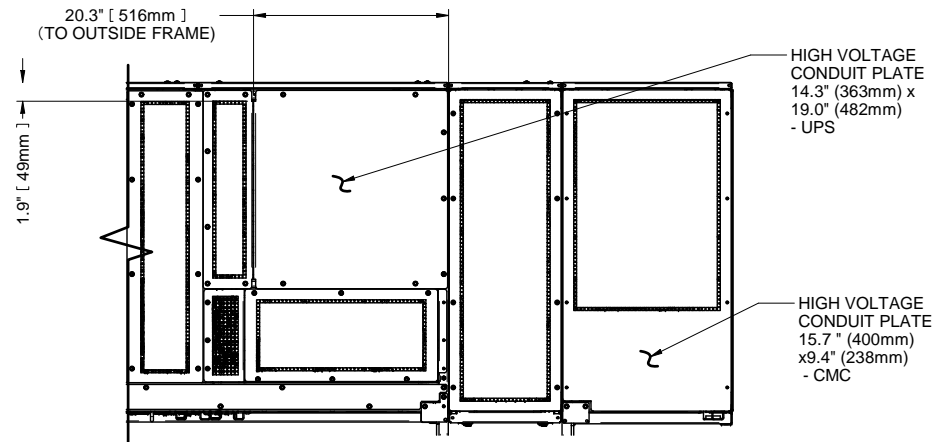

**DETAIL "1"**  
(CABLE ENTRY CONDUIT PLATE)

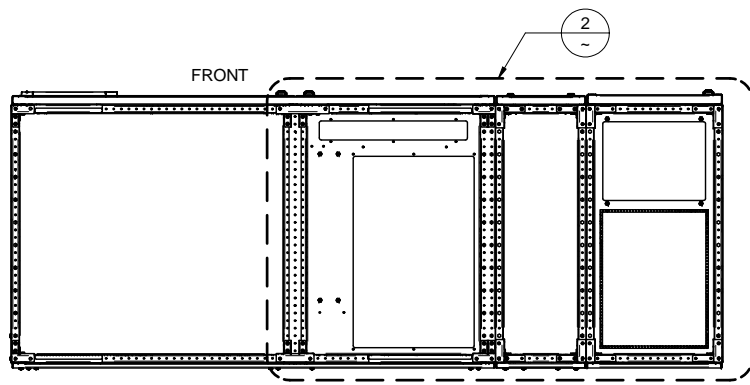

**BOTTOM VIEW**

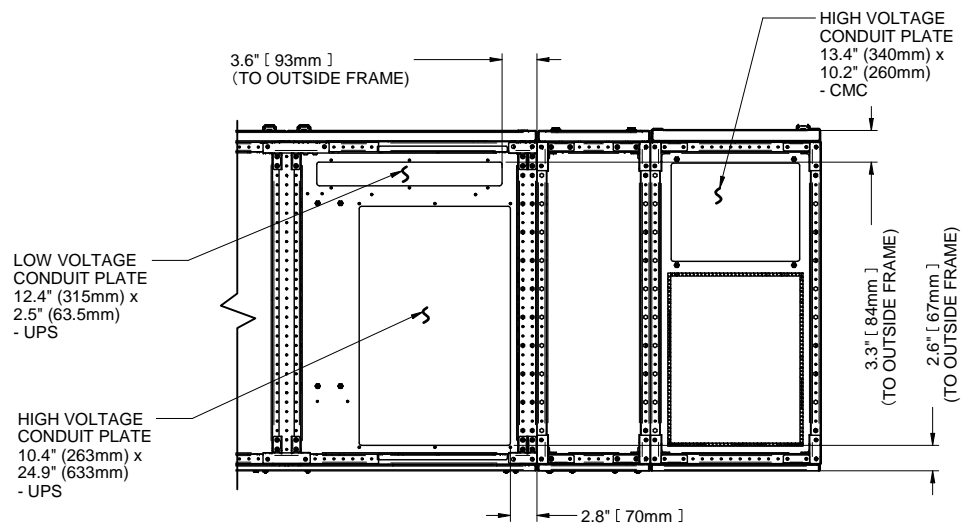

**DETAIL "2"**  
(CABLE ENTRY CONDUIT PLATE)

- NOTES**
1. ALL DIMENSIONS ARE IN inches [mm].
  2. UNIT BOTTOM IS STRUCTURALLY ADEQUATE FOR FORKLIFT HANDLING.

SHEET NO. 4 OF 6	DRAWN BY: JASON ZHANG	TITLE
ECN NO.	DESIGNED BY: JASON ZHANG	<b>UPS CONDUIT PLATE DETAILS</b> <b>SMS AND 1+N MULTI-MODULE, 500kVA-600kVA UPS, 480V,</b> <b>WITH BFD AND COMMON MODE CHOKE</b> <b>LIEBERT EXL S1</b>
REF DWG.	APPROVED BY: S. MAJOR	
REF DWG		

DWG. NO. ES1-05-S030
DATE (LATEST REV.) 3/19/2020
REVISION 0
1050 DEARBORN DR P.O. BOX 29186 COLUMBUS, OH 43229



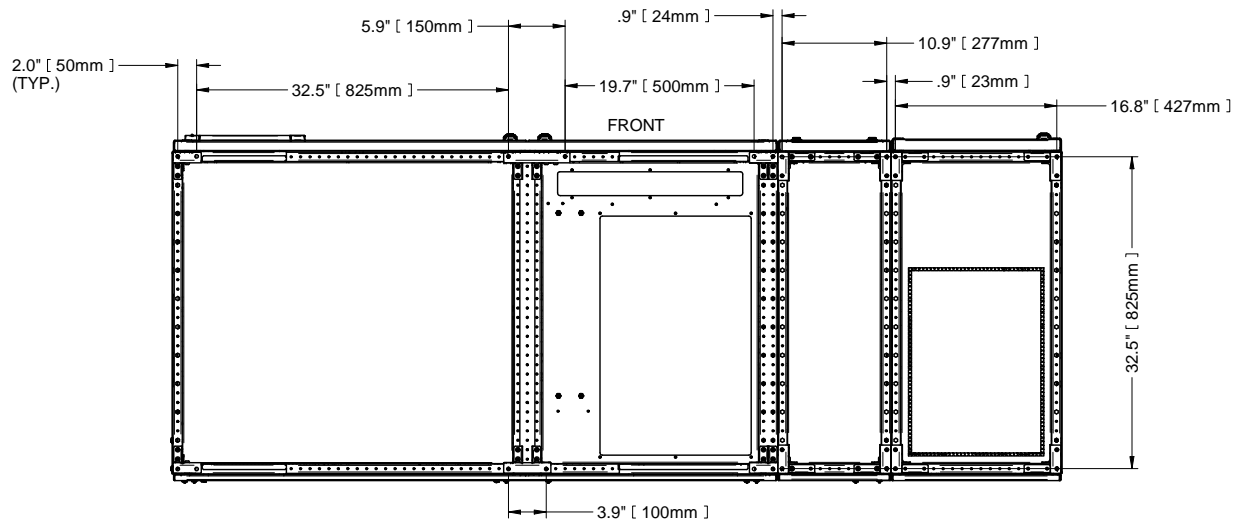

**BOTTOM VIEW**  
(BOLT HOLE LAYOUT)

**NOTES**

1. ALL DIMENSIONS ARE IN inches [mm].
2. UNIT BOTTOM IS STRUCTURALLY ADEQUATE FOR FORKLIFT HANDLING.

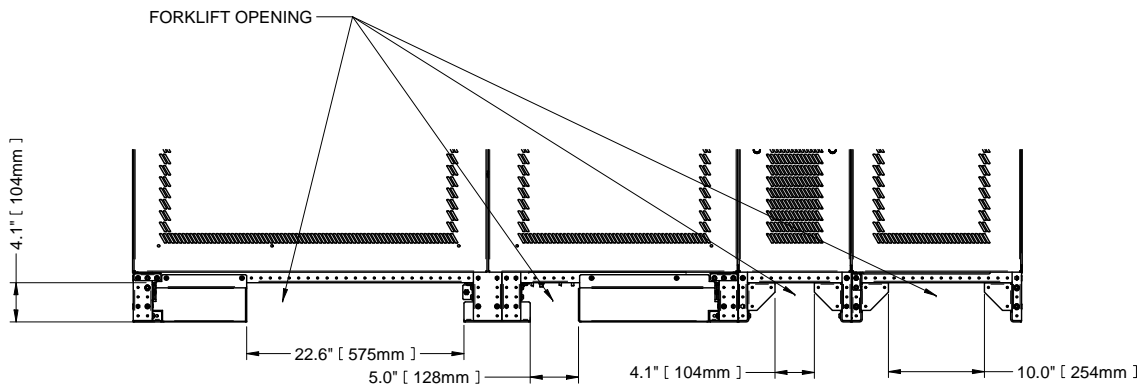

**FRONT VIEW**

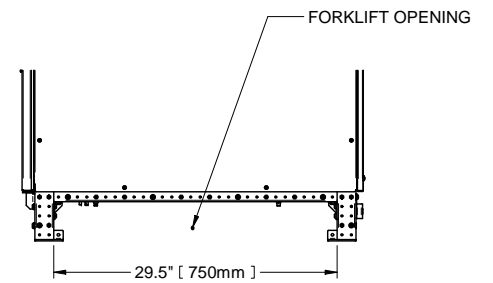

**RIGHT SIDE VIEW**

SHEET NO. 5 OF 6	DRAWN BY: JASON ZHANG	TITLE  <b>UPS BASE DRAWING</b> <b>SMS AND 1+N MULTI-MODULE, 500kVA-600kVA UPS, 480V,</b> <b>WITH BFD AND COMMON MODE CHOKE</b> <b>LIEBERT EXL S1</b>
ECN NO.	DESIGNED BY: JASON ZHANG	
REF DWG.	APPROVED BY:	
REF DWG	S. MAJOR	

DWG. NO. ES1-05-S030
DATE (LATEST REV.) 3/19/2020
REVISION 0
1050 DEARBORN DR P.O. BOX 29186 COLUMBUS, OH 43229



NOTES

1. ALL DIMENSIONS ARE IN inches [mm].

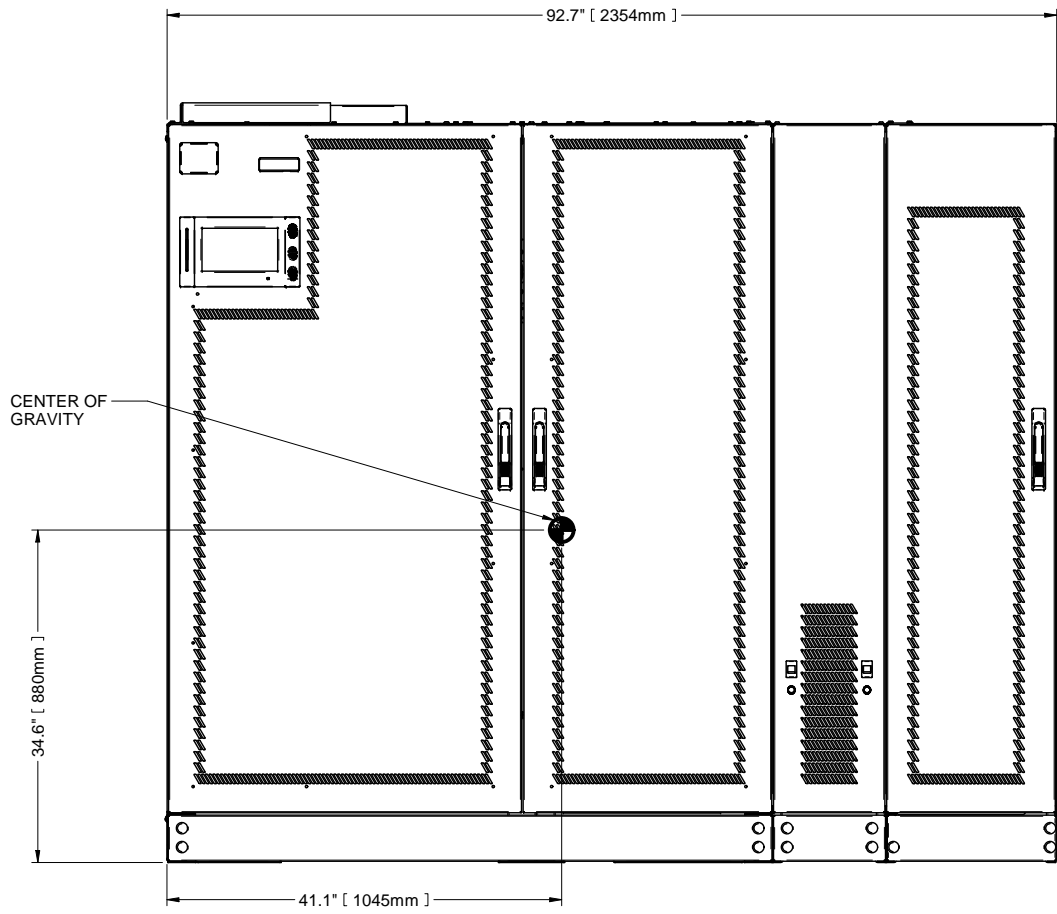

FRONT VIEW

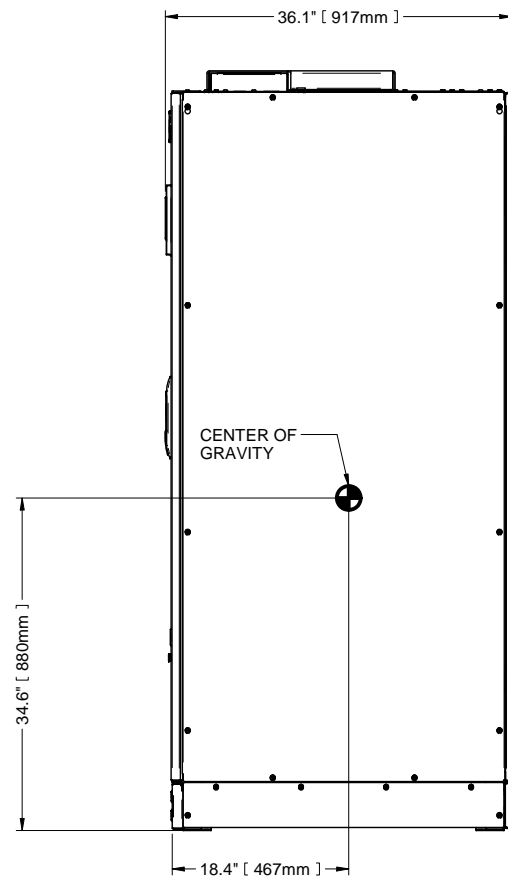

RIGHT SIDE VIEW

SHEET NO. 6 OF 6	DRAWN BY: JASON ZHANG	TITLE <b>UPS SHIPPING</b> SMS AND 1+N MULTI-MODULE, 500kVA-600kVA UPS, 480V, WITH BFD AND COMMON MODE CHOKE LIEBERT EXL S1	DWG. NO. ES1-05-S030		
ECN NO.	DESIGNED BY: JASON ZHANG		DATE (LATEST REV.) 3/19/2020		
ECN NO.	APPROVED BY: S. MAJOR		REVISION 0		1050 DEARBORN DR P.O. BOX 29186 COLUMBUS, OH 43229
REF DWG.	REF DWG				

- NOTES
1. ALL DIMENSIONS ARE IN inches [mm].
  2. 24" [610mm] MINIMUM CLEARANCE ABOVE UNIT REQUIRED FOR AIR EXHAUST. 36" [914mm] FRONT ACCESS IS REQUIRED FOR SERVICE.
  3. KEEP CABINET WITHIN 15 DEGREES OF VERTICAL.
  4. ALL WIRING MUST BE IN ACCORDANCE WITH NATIONAL AND LOCAL ELECTRICAL CODES.
  5. UNIT BOTTOM IS STRUCTURALLY ADEQUATE FOR FORKLIFT HANDLING.
  6. WIDTH DIMENSIONS INCLUDE SIDE PANELS.

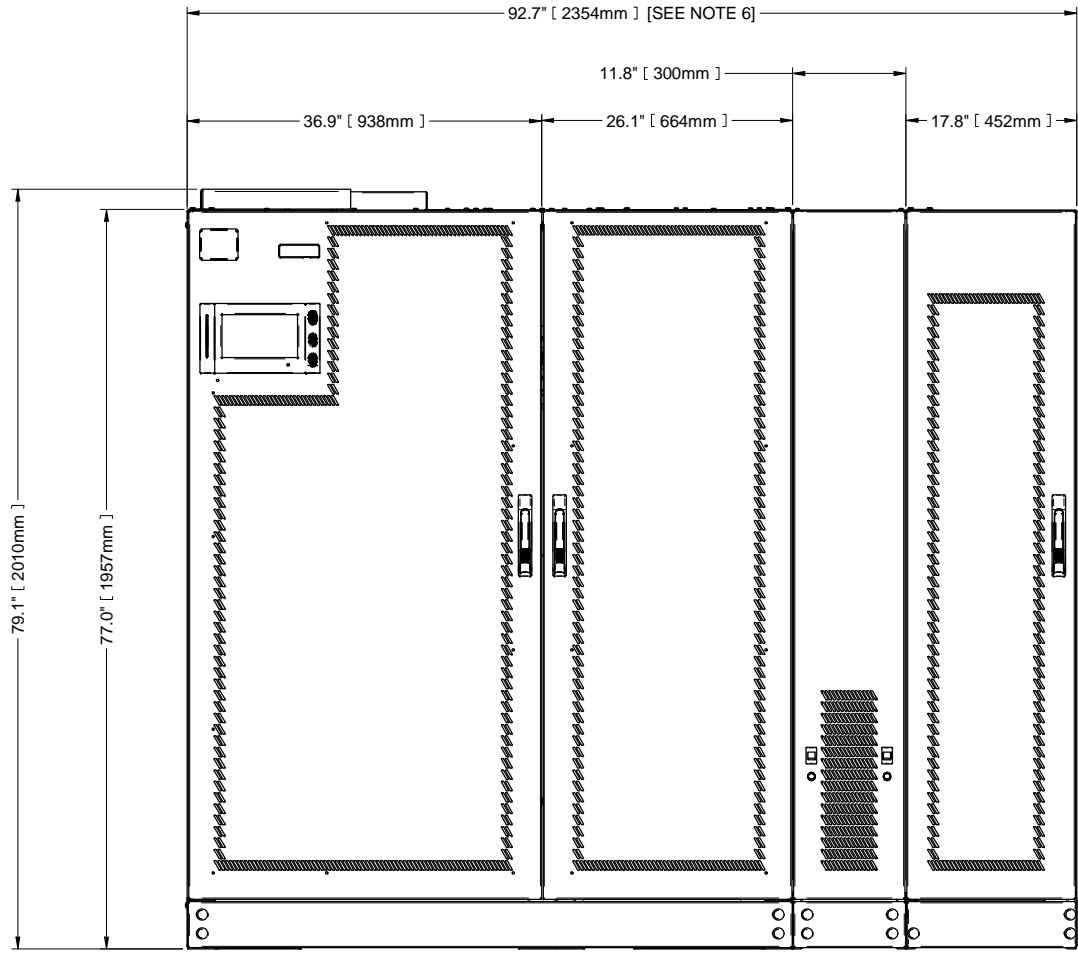

FRONT VIEW

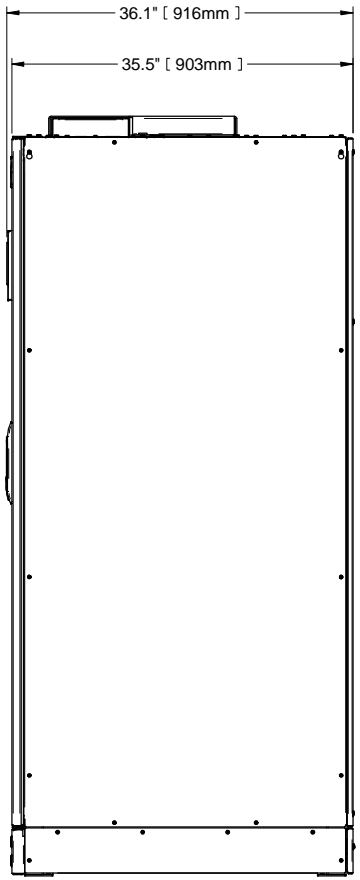

RIGHT SIDE VIEW

SHEET NO. 1 OF 6	DRAWN BY: JASON ZHANG	TITLE  OUTLINE DRAWING SMS AND 1+N MULTI-MODULE, 500kVA-600kVA UPS, 480V, WITH SHARING INDUCTOR AND COMMON MODE CHOKE LIEBERT EXL S1
ECN NO	DESIGNED BY: JASON ZHANG	
REF DWG.	APPROVED BY:	
REF DWG	S. MAJOR	

DWG. NO. ES1-05-S031	1050 DEARBORN DR P.O. BOX 29186 COLUMBUS, OH 43229
DATE (LATEST REV.) 9/23/2019	
REVISION 0	





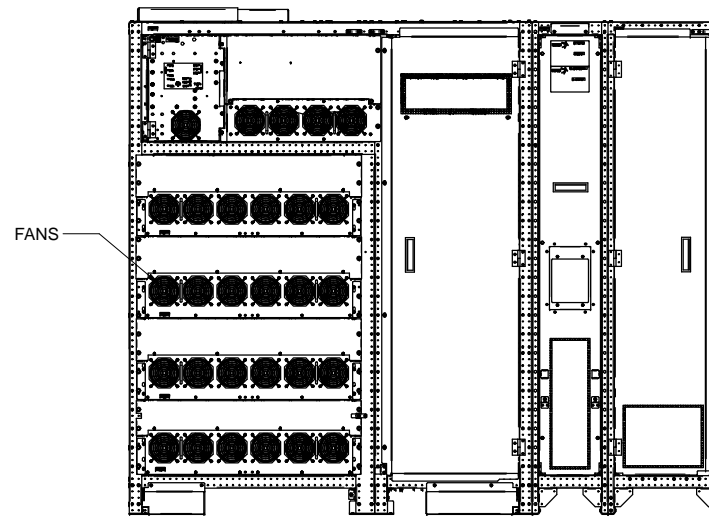

FRONT VIEW  
(DOORS REMOVED)

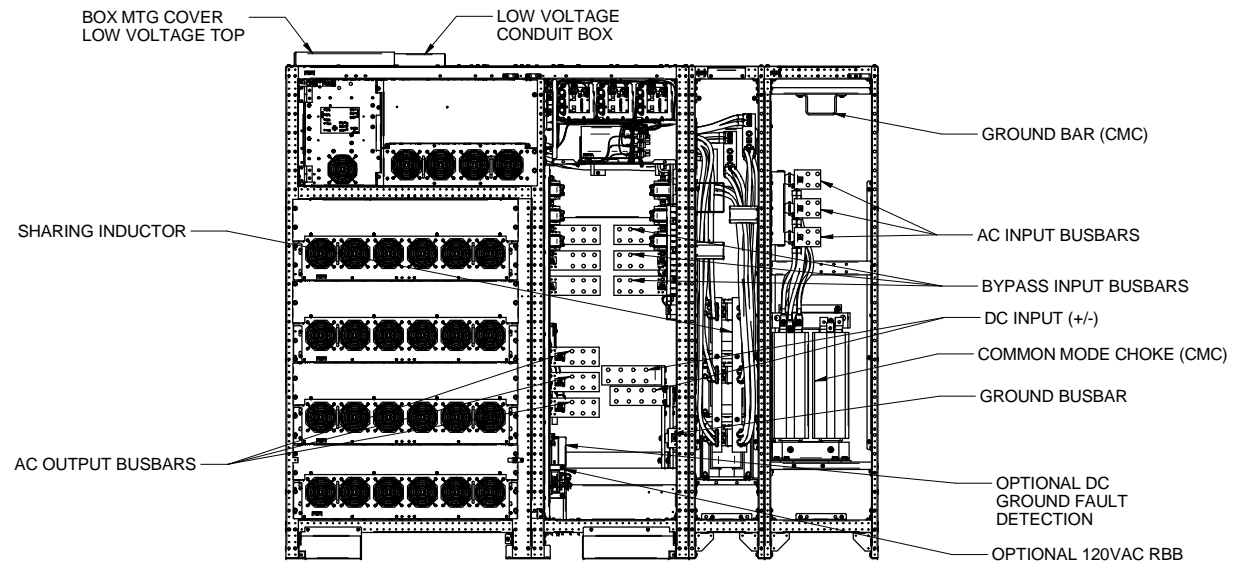

FRONT VIEW  
(DOORS AND PANELS REMOVED)

SHEET NO. 2 OF 6	DRAWN BY: JASON ZHANG	TITLE
ECN NO.	DESIGNED BY: JASON ZHANG	<p>MAIN COMPONENTS DRAWING</p> <p>SMS AND 1+N MULTI-MODULE, 500kVA-600kVA UPS, 480V, WITH SHARING INDUCTOR AND COMMON MODE CHOKE</p> <p>LIEBERT EXL S1</p>
REF DWG.	APPROVED BY: S. MAJOR	
REF DWG		

DWG. NO. ES1-05-S031
DATE (LATEST REV.) 9/23/2019
REVISION 0
1050 DEARBORN DR P.O. BOX 29186 COLUMBUS, OH 43229



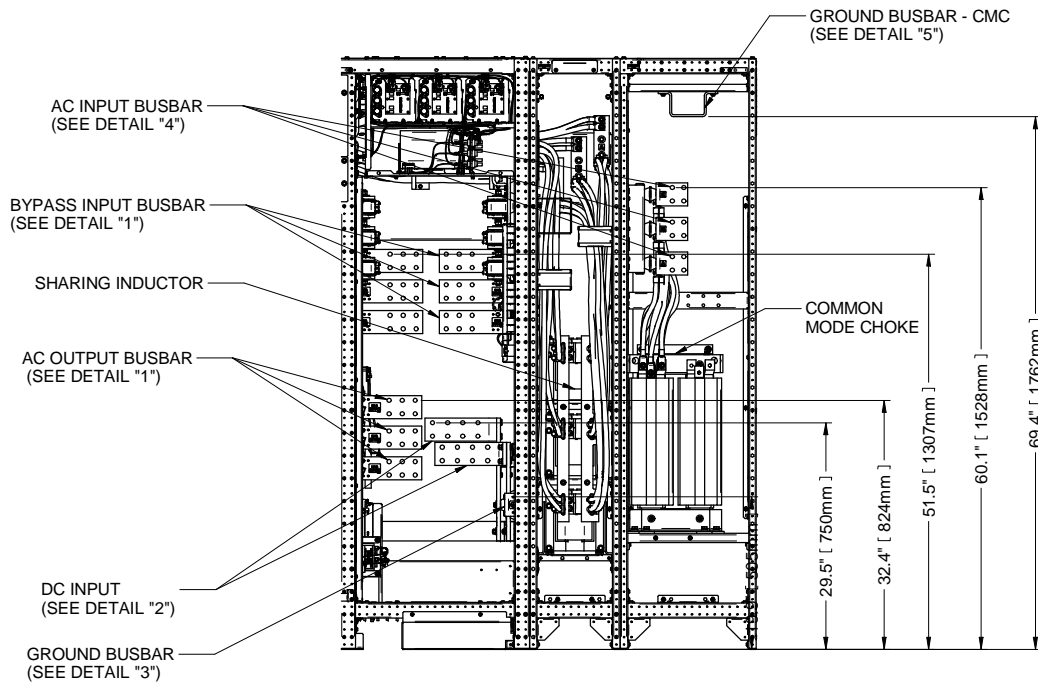
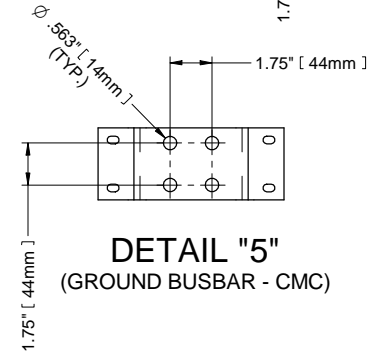
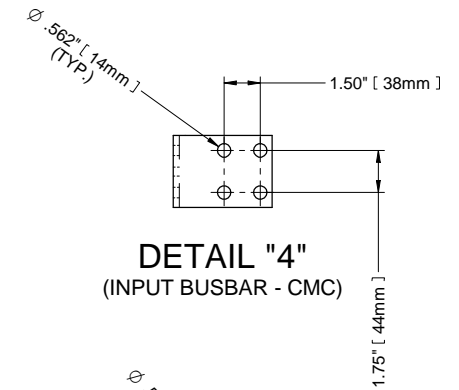
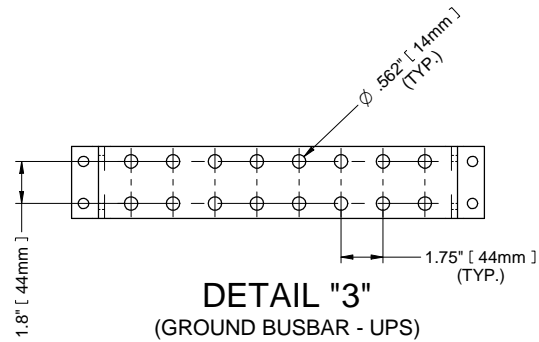
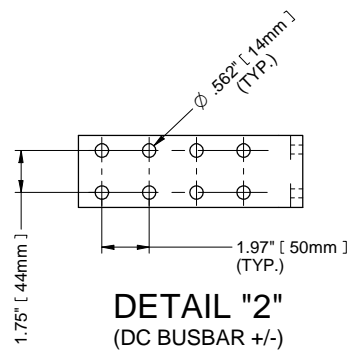
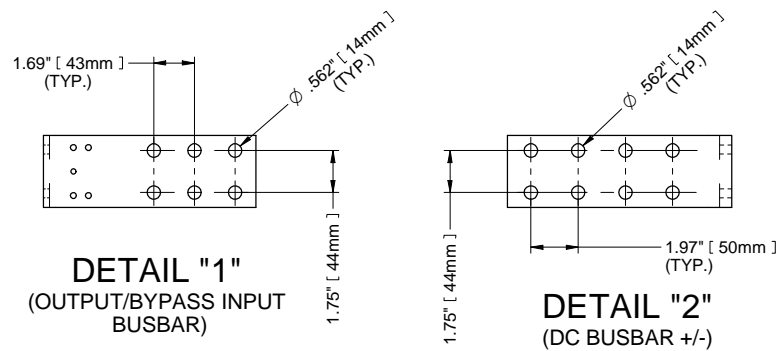

**FRONT VIEW**

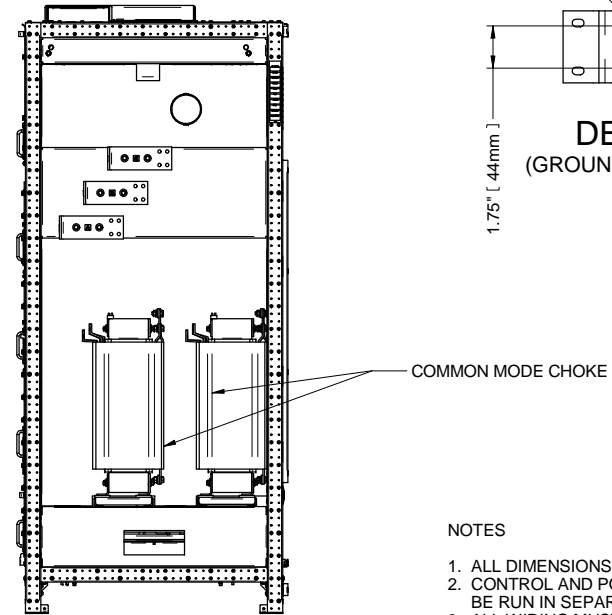

**RIGHT SIDE VIEW**

**NOTES**

1. ALL DIMENSIONS ARE IN inches [mm].
2. CONTROL AND POWER WIRING MUST BE RUN IN SEPARATE CONDUITS.
3. ALL WIRING MUST BE IN ACCORDANCE WITH NATIONAL AND LOCAL ELECTRICAL CODES.
4. COPPER AND ALUMINUM CABLES ARE ACCEPTABLE

SHEET NO. 3 OF 6	DRAWN BY: JASON ZHANG	TITLE
ECN NO.	DESIGNED BY: JASON ZHANG	<b>UPS ELECTRICAL CONNECTION</b> <b>SMS AND 1+N MULTI-MODULE, 500kVA-600kVA UPS, 480V,</b> <b>WITH SHARING INDUCTOR AND COMMON MODE CHOKE</b> <b>LIEBERT EXL S1</b>
REF DWG.	APPROVED BY: S. MAJOR	
REF DWG		

DWG. NO. ES1-05-S031
DATE (LATEST REV.) 9/23/2019
REVISION 0
1050 DEARBORN DR P.O. BOX 29186 COLUMBUS, OH 43229



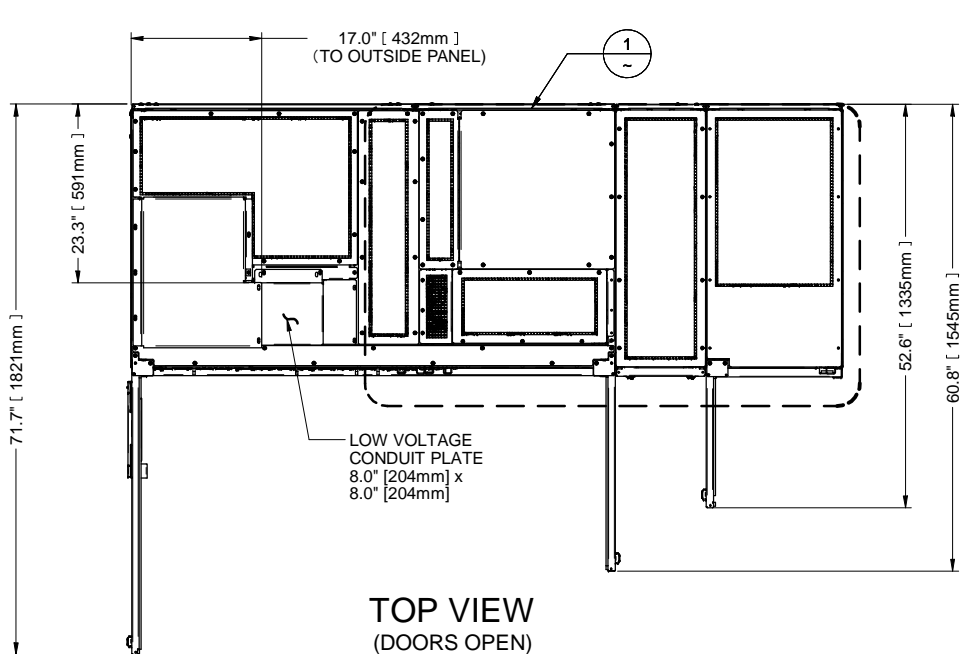

**TOP VIEW**  
(DOORS OPEN)

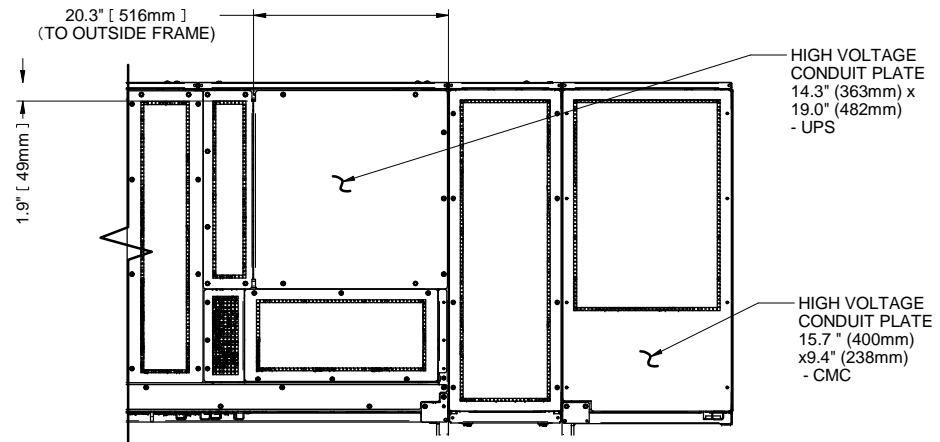

**DETAIL "1"**  
(CABLE ENTRY CONDUIT PLATE)

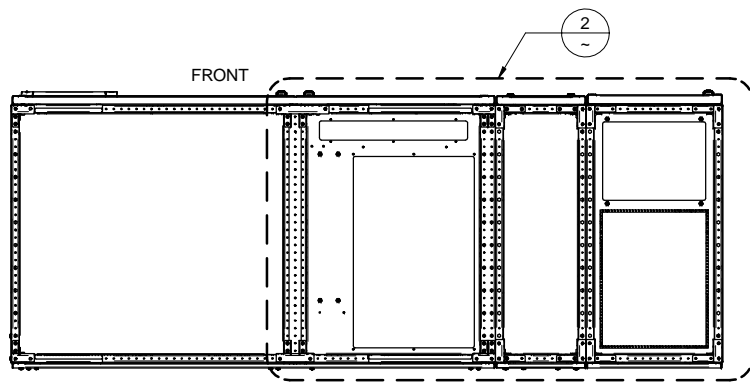

**BOTTOM VIEW**

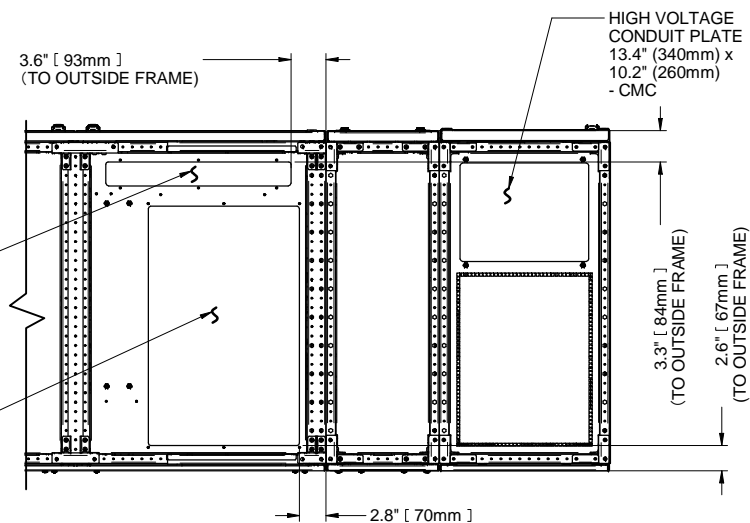

**DETAIL "2"**  
(CABLE ENTRY CONDUIT PLATE)

- NOTES**
1. ALL DIMENSIONS ARE IN inches [mm].
  2. UNIT BOTTOM IS STRUCTURALLY ADEQUATE FOR FORKLIFT HANDLING.

SHEET NO. 4 OF 6	DRAWN BY: JASON ZHANG	TITLE
ECN NO.	DESIGNED BY: JASON ZHANG	<p align="center"><b>UPS CONDUIT PLATE DETAILS</b></p> <p align="center">SMS AND 1+N MULTI-MODULE, 500kVA-600kVA UPS, 480V, WITH SHARING INDUCTOR AND COMMON MODE CHOKE</p> <p align="center">LIEBERT EXL S1</p>
REF DWG.	APPROVED BY: S. MAJOR	
REF DWG		

DWG. NO. ES1-05-S031
DATE (LATEST REV.) 9/23/2019
REVISION 0
1050 DEARBORN DR P.O. BOX 29186 COLUMBUS, OH 43229



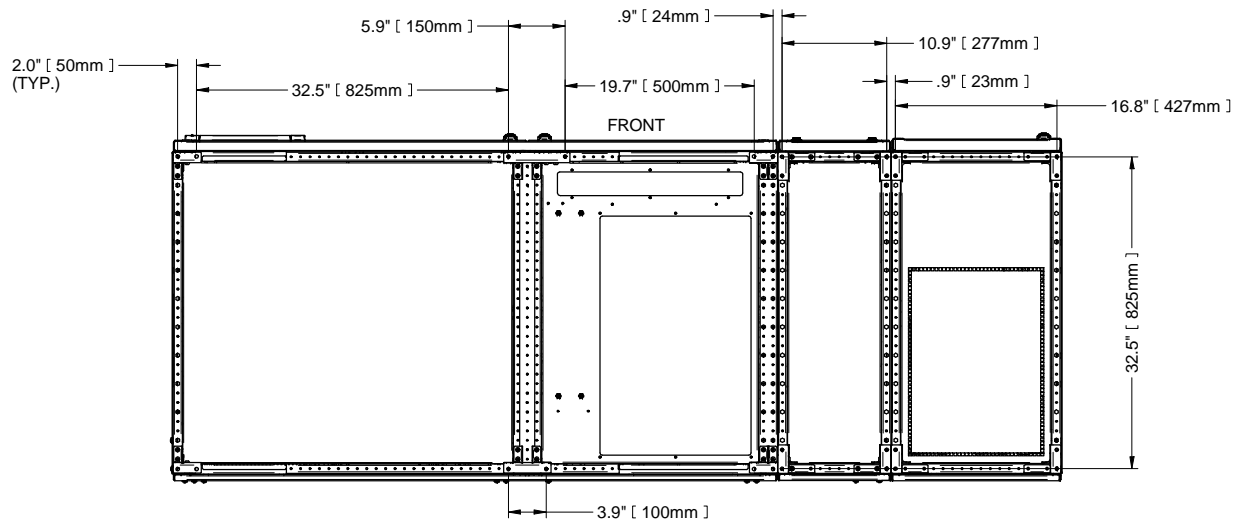

**BOTTOM VIEW**  
(BOLT HOLE LAYOUT)

**NOTES**

1. ALL DIMENSIONS ARE IN inches [mm].
2. UNIT BOTTOM IS STRUCTURALLY ADEQUATE FOR FORKLIFT HANDLING.

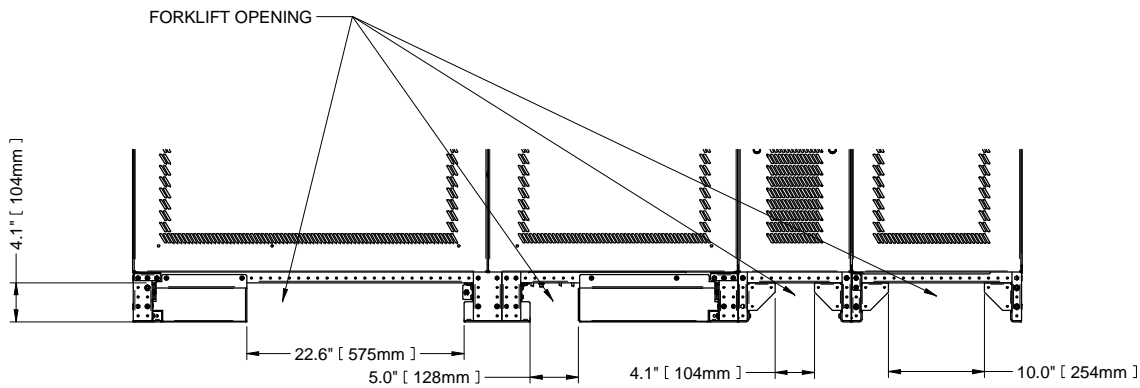

**FRONT VIEW**

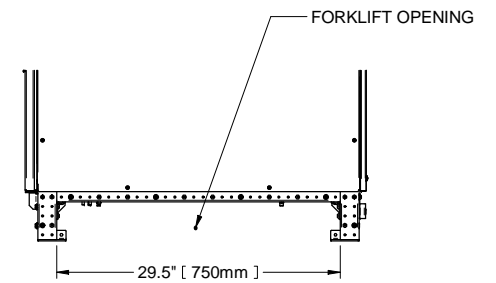

**RIGHT SIDE VIEW**

SHEET NO.	DRAWN BY:	TITLE
5 OF 6	JASON ZHANG	<b>UPS BASE DRAWING</b> <b>SMS AND 1+N MULTI-MODULE, 500kVA-600kVA UPS, 480V,</b> <b>WITH SHARING INDUCTOR AND COMMON MODE CHOKE</b> <b>LIEBERT EXL S1</b>
ECN NO.	DESIGNED BY:	
ECN NO	JASON ZHANG	
REF DWG.	APPROVED BY:	
REF DWG	S. MAJOR	

DWG. NO.	ES1-05-S031
DATE (LATEST REV.)	9/23/2019
REVISION	1050 DEARBORN DR P.O. BOX 29186 COLUMBUS, OH 43229
0	



NOTES

1. ALL DIMENSIONS ARE IN inches [mm].

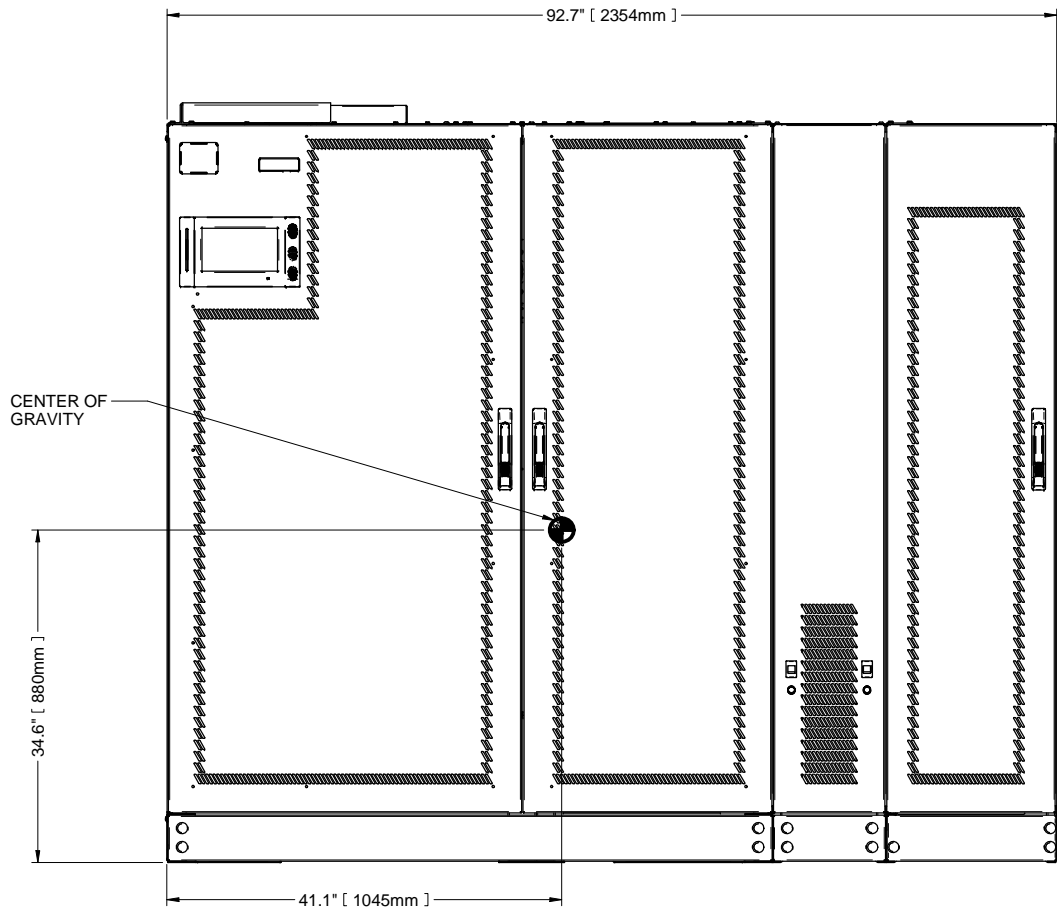

FRONT VIEW

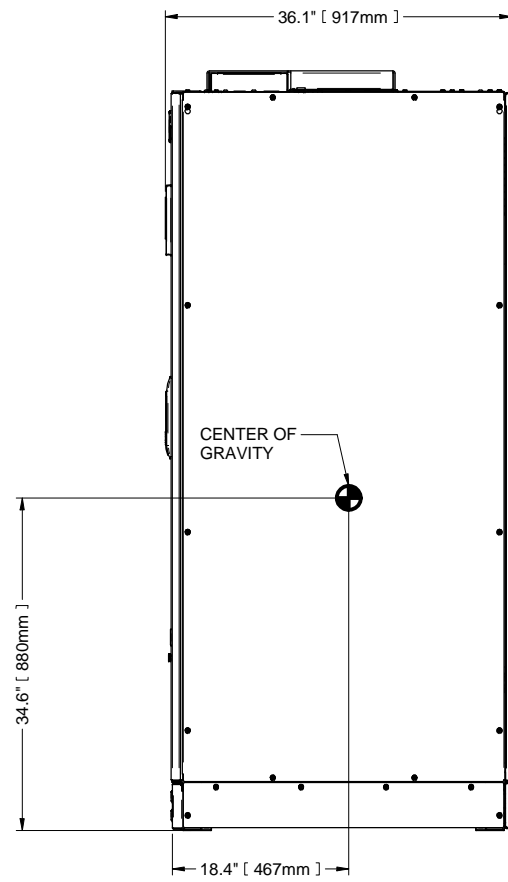

RIGHT SIDE VIEW

SHEET NO. 6 OF 6	DRAWN BY: JASON ZHANG
ECN NO. ECN NO	DESIGNED BY: JASON ZHANG
REF DWG. REF DWG	APPROVED BY: S. MAJOR

TITLE <b>UPS SHIPPING</b> <b>SMS AND 1+N MULTI-MODULE, 500kVA-600kVA UPS, 480V, WITH SHARING INDUCTOR AND COMMON MODE CHOKE</b> <b>LIEBERT EXL S1</b>
--

DWG. NO. ES1-05-S031
DATE (LATEST REV.) 9/23/2019
REVISION 0
1050 DEARBORN DR P.O. BOX 29186 COLUMBUS, OH 43229



- NOTES
1. ALL DIMENSIONS ARE IN inches [mm].
  2. 24" [610mm] MINIMUM CLEARANCE ABOVE UNIT REQUIRED FOR AIR EXHAUST. 36" [914mm] FRONT ACCESS IS REQUIRED FOR SERVICE.
  3. KEEP CABINET WITHIN 15 DEGREES OF VERTICAL.
  4. ALL WIRING MUST BE IN ACCORDANCE WITH NATIONAL AND LOCAL ELECTRICAL CODES.
  5. UNIT BOTTOM IS STRUCTURALLY ADEQUATE FOR FORKLIFT HANDLING.
  6. WIDTH DIMENSIONS INCLUDE SIDE PANELS.

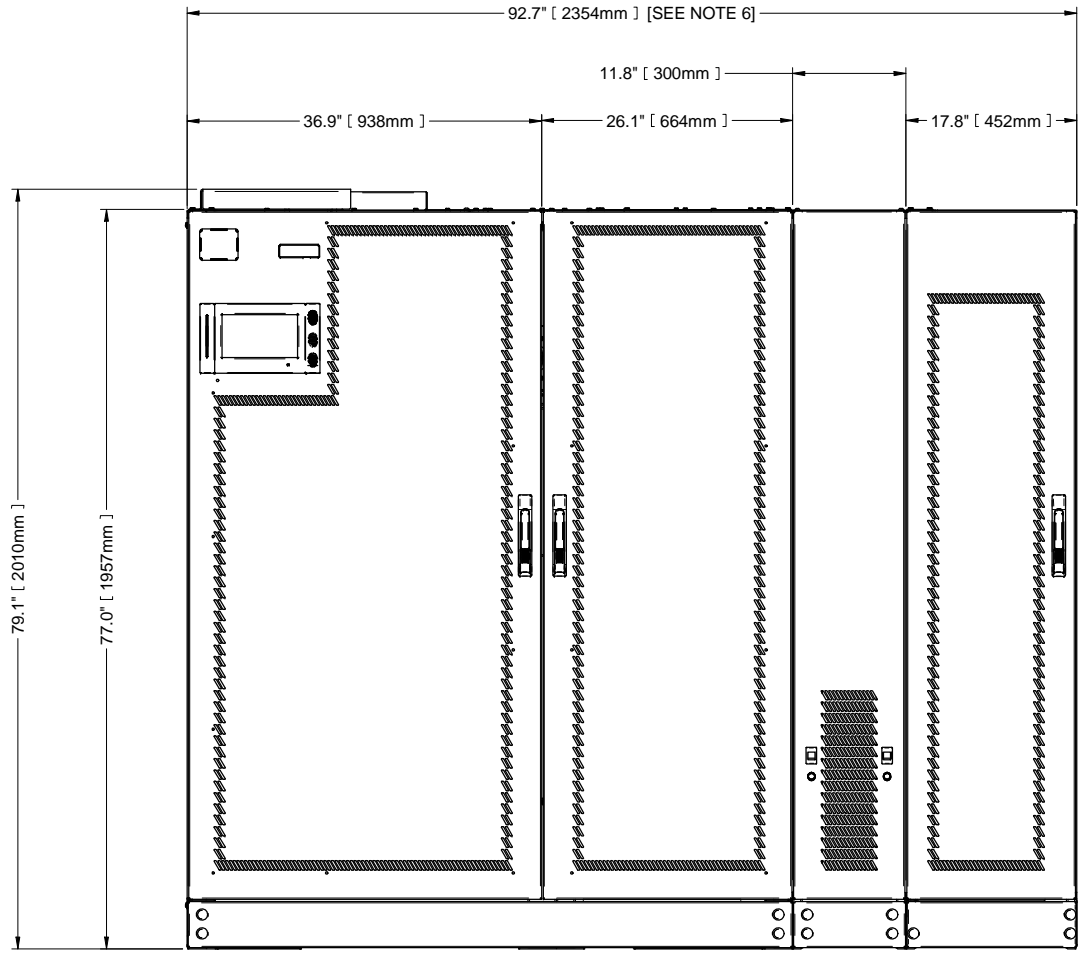

FRONT VIEW

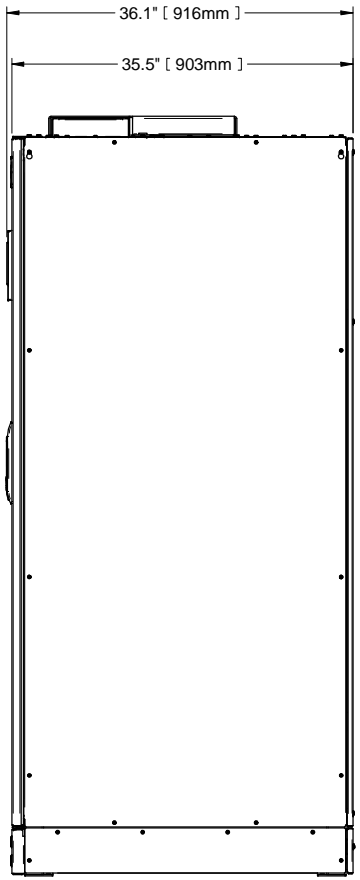

RIGHT SIDE VIEW

SHEET NO. 1 OF 6	DRAWN BY: JASON ZHANG
ECN NO.	DESIGNED BY: JASON ZHANG
REF DWG.	APPROVED BY: S. MAJOR
REF DWG	

TITLE

OUTLINE DRAWING

SMS AND 1+N MULTI-MODULE, 500kVA-600kVA UPS, 480V,  
WITH BFD, SHARING INDUCTOR AND COMMON MODE CHOKE

LIEBERT EXL S1

DWG. NO. ES1-05-S032
DATE (LATEST REV.) 9/23/2019
REVISION 0
1050 DEARBORN DR P.O. BOX 29186 COLUMBUS, OH 43229



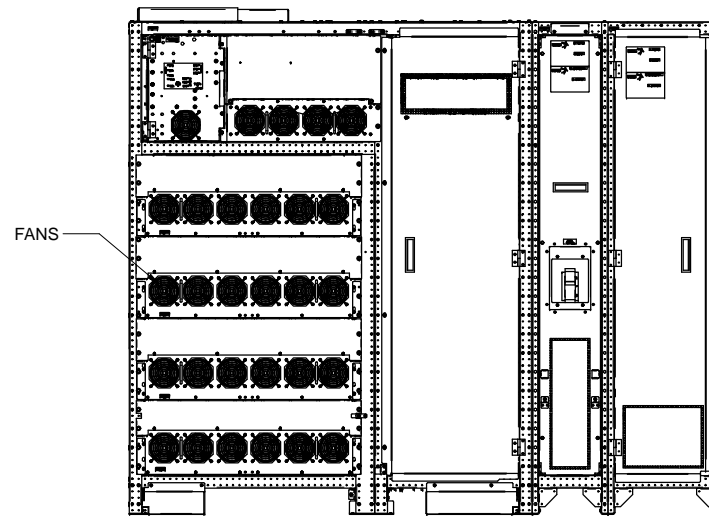

FRONT VIEW  
(DOORS REMOVED)

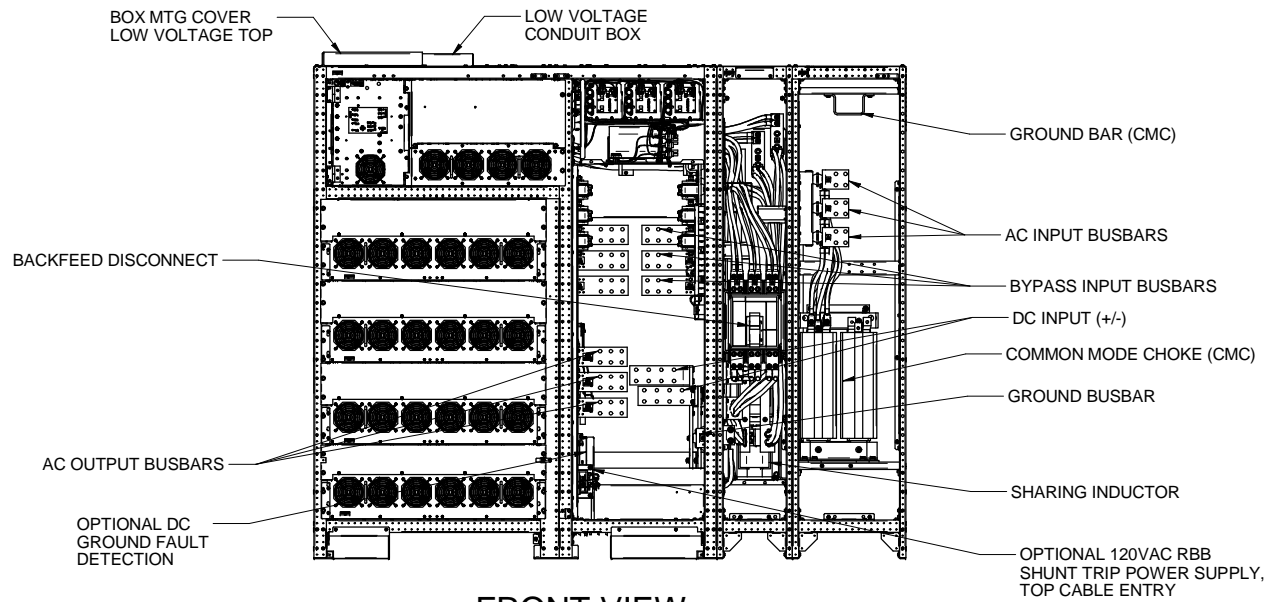

FRONT VIEW  
(DOORS AND PANELS REMOVED)

SHEET NO. 2 OF 6	DRAWN BY: JASON ZHANG	TITLE
ECN NO.	DESIGNED BY: JASON ZHANG	<b>MAIN COMPONENTS DRAWING</b> <b>SMS AND 1+N MULTI-MODULE, 500kVA-600kVA UPS, 480V,          WITH BFD, SHARING INDUCTOR AND COMMON MODE CHOKE</b> <b>LIEBERT EXL S1</b>
REF DWG.	APPROVED BY: S. MAJOR	
REF DWG		

DWG. NO. ES1-05-S032
DATE (LATEST REV.) 9/23/2019
REVISION 0
1050 DEARBORN DR P.O. BOX 29186 COLUMBUS, OH 43229



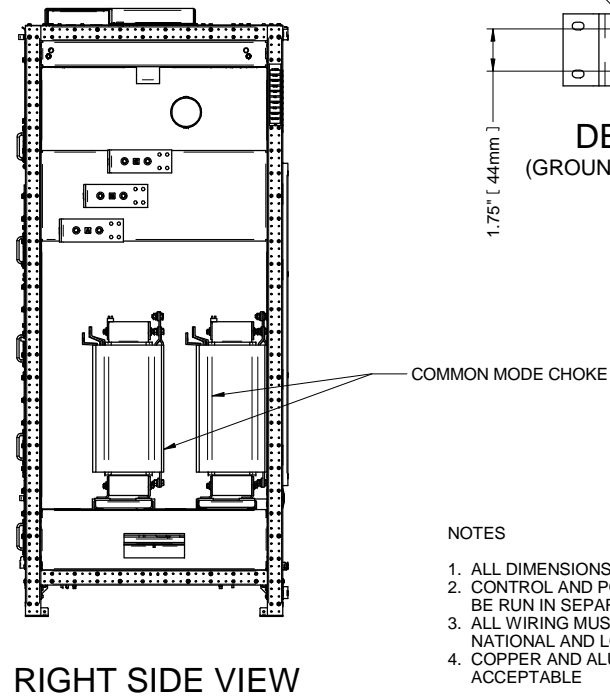
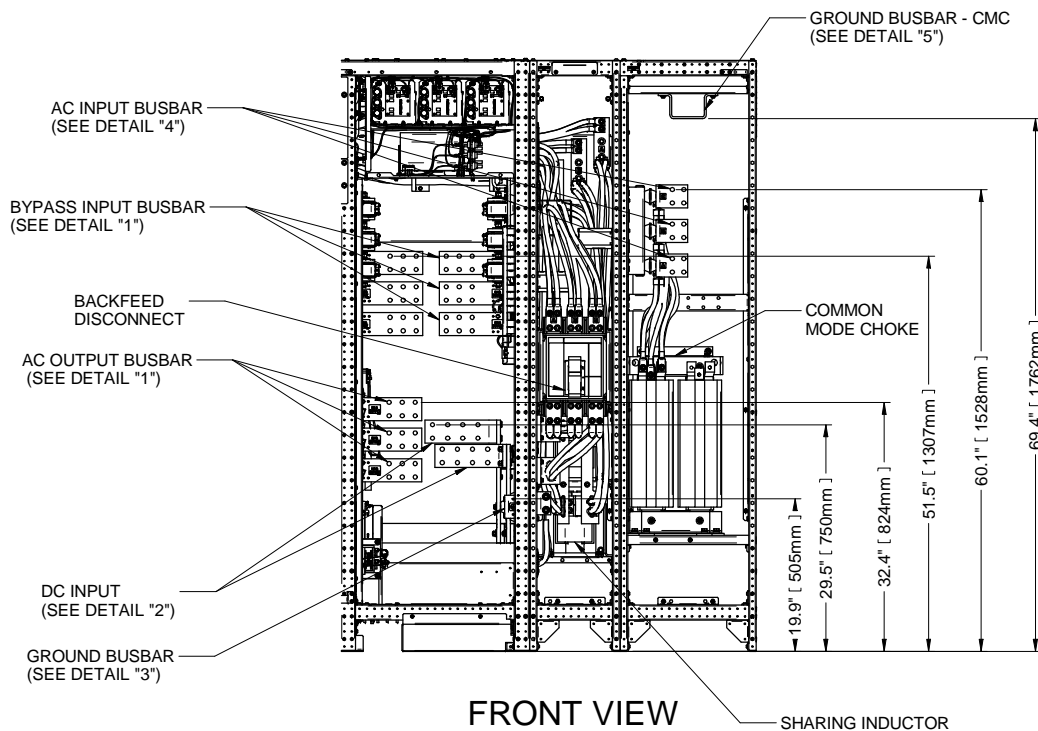
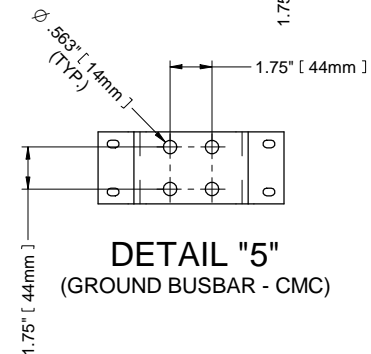
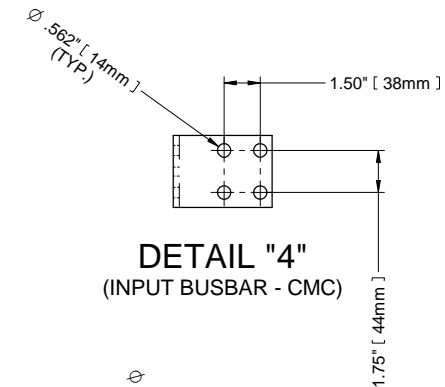
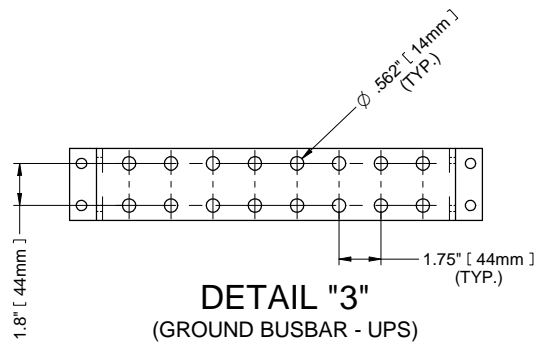
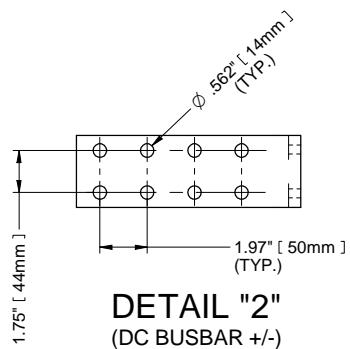
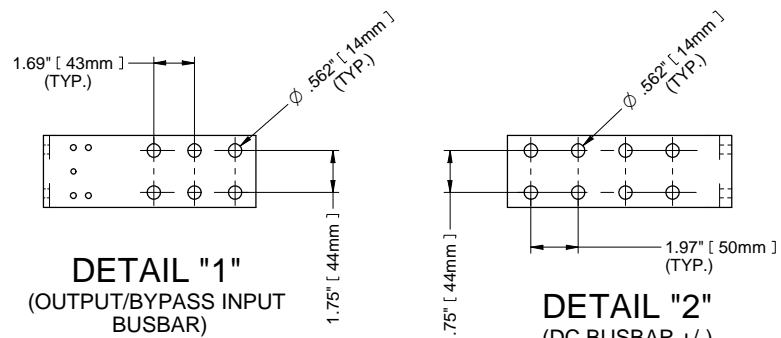

**NOTES**

1. ALL DIMENSIONS ARE IN inches [mm].
2. CONTROL AND POWER WIRING MUST BE RUN IN SEPARATE CONDUITS.
3. ALL WIRING MUST BE IN ACCORDANCE WITH NATIONAL AND LOCAL ELECTRICAL CODES.
4. COPPER AND ALUMINUM CABLES ARE ACCEPTABLE

SHEET NO. 3 OF 6	DRAWN BY: JASON ZHANG	TITLE
ECN NO.	DESIGNED BY: JASON ZHANG	<b>UPS ELECTRICAL CONNECTION</b> SMS AND 1+N MULTI-MODULE, 500kVA-600kVA UPS, 480V, WITH BFD, SHARING INDUCTOR AND COMMON MODE CHOKE <b>LIEBERT EXL S1</b>
REF DWG.	APPROVED BY: S. MAJOR	
REF DWG		

DWG. NO. ES1-05-S032
DATE (LATEST REV.) 9/23/2019
REVISION 0
1050 DEARBORN DR P.O. BOX 29186 COLUMBUS, OH 43229





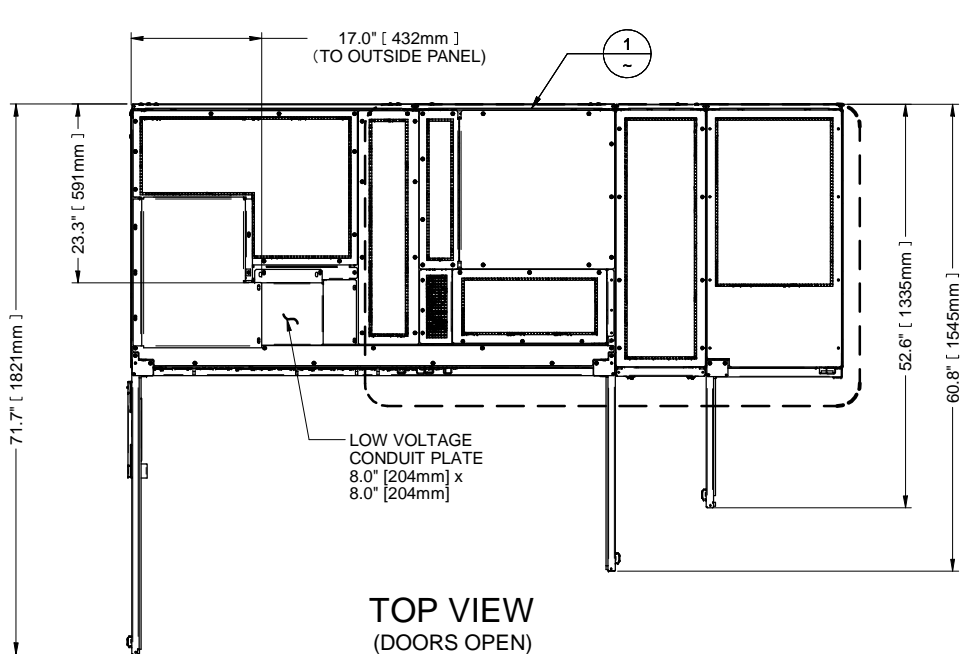

**TOP VIEW**  
(DOORS OPEN)

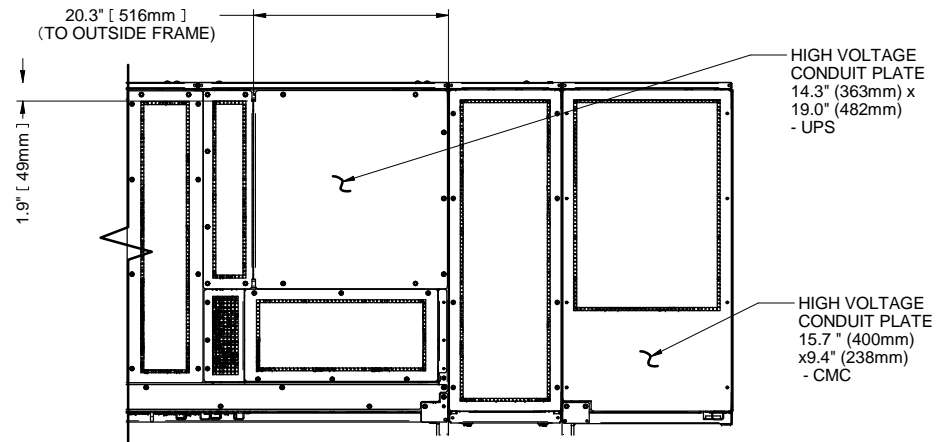

**DETAIL "1"**  
(CABLE ENTRY CONDUIT PLATE)

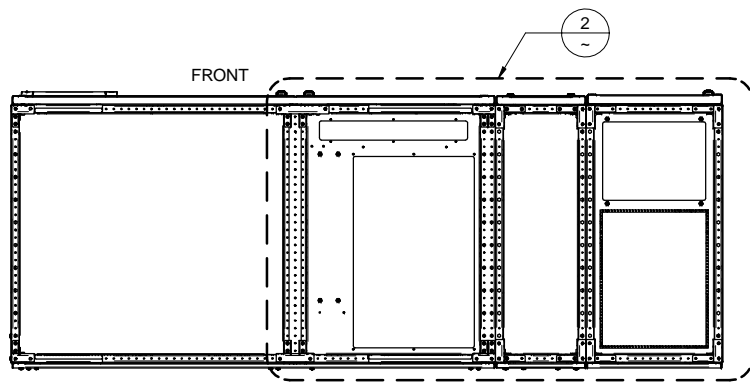

**BOTTOM VIEW**

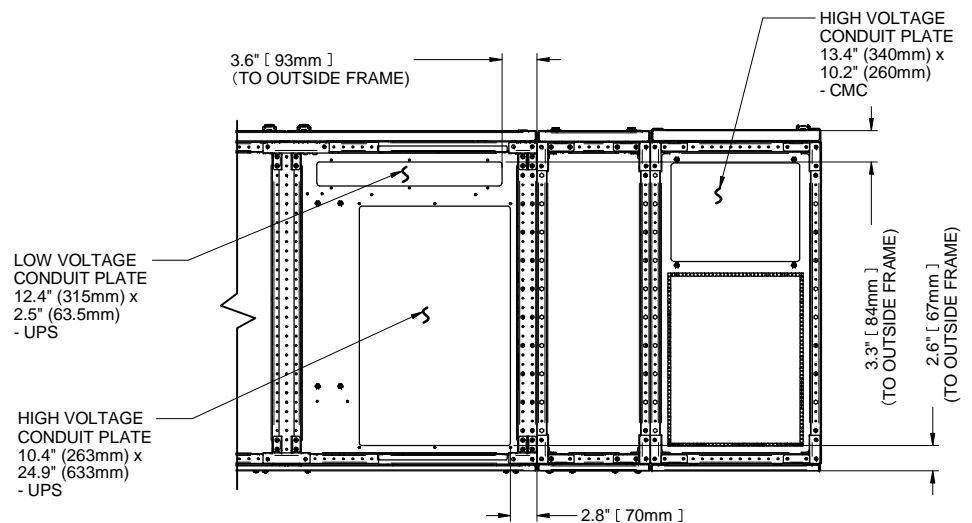

**DETAIL "2"**  
(CABLE ENTRY CONDUIT PLATE)

- NOTES**
1. ALL DIMENSIONS ARE IN inches [mm].
  2. UNIT BOTTOM IS STRUCTURALLY ADEQUATE FOR FORKLIFT HANDLING.

SHEET NO. 4 OF 6	DRAWN BY: JASON ZHANG	<b>TITLE</b>  <b>UPS CONDUIT PLATE DETAILS</b>  SMS AND 1+N MULTI-MODULE, 500kVA-600kVA UPS, 480V, WITH BFD, SHARING INDUCTOR AND COMMON MODE CHOKE  <b>LIEBERT EXL S1</b>	DWG. NO. ES1-05-S032	
ECN NO.	DESIGNED BY: JASON ZHANG		DATE (LATEST REV.) 9/23/2019	
REF DWG.	APPROVED BY: S. MAJOR		REVISION 0	1050 DEARBORN DR P.O. BOX 29186 COLUMBUS, OH 43229
REF DWG				

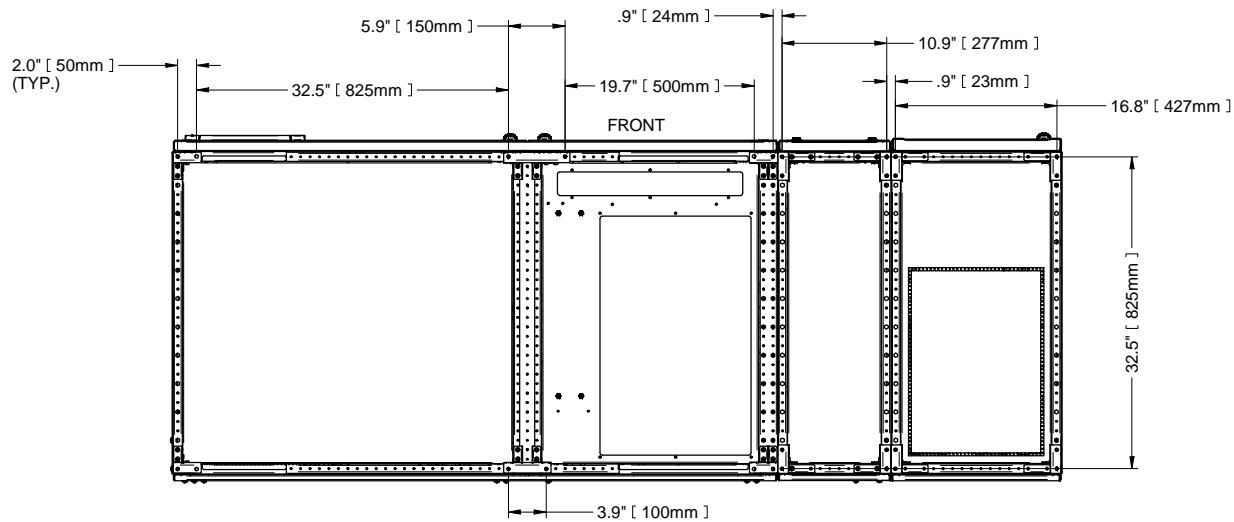

**BOTTOM VIEW**  
(BOLT HOLE LAYOUT)

**NOTES**

1. ALL DIMENSIONS ARE IN inches [mm].
2. UNIT BOTTOM IS STRUCTURALLY ADEQUATE FOR FORKLIFT HANDLING.

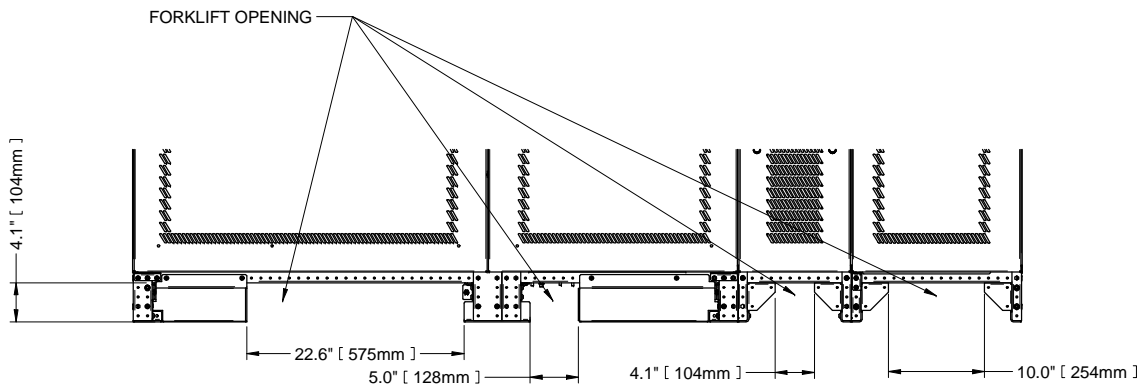

**FRONT VIEW**

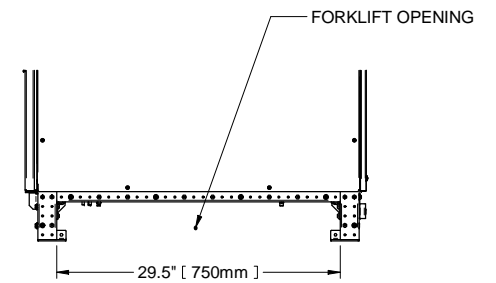

**RIGHT SIDE VIEW**

SHEET NO. 5 OF 6	DRAWN BY: JASON ZHANG	TITLE  <b>UPS BASE DRAWING</b> SMS AND 1+N MULTI-MODULE, 500kVA-600kVA UPS, 480V, WITH BFD, SHARING INDUCTOR AND COMMON MODE CHOKE LIEBERT EXL S1
ECN NO.	DESIGNED BY: JASON ZHANG	
REF DWG.	APPROVED BY:	
REF DWG	S. MAJOR	

DWG. NO. ES1-05-S032	1050 DEARBORN DR P.O. BOX 29186 COLUMBUS, OH 43229
DATE (LATEST REV.) 9/23/2019	
REVISION 0	



NOTES

1. ALL DIMENSIONS ARE IN inches [mm].

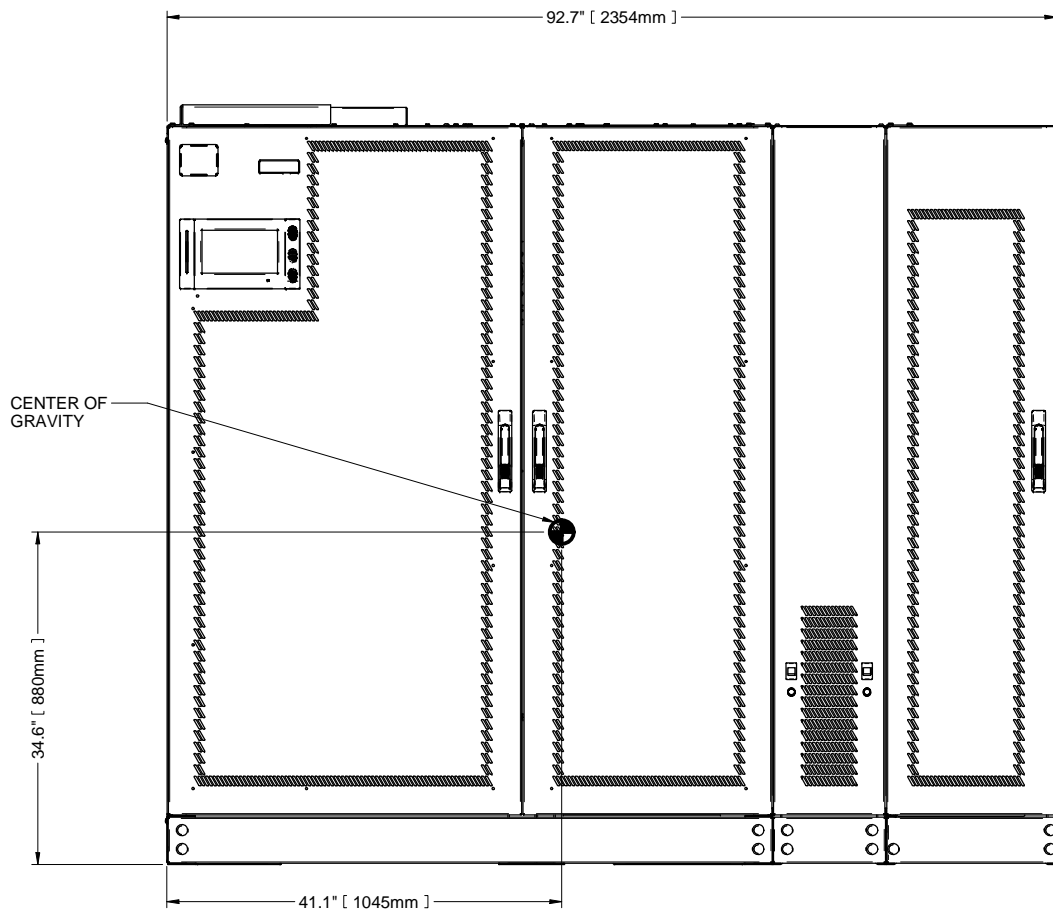

FRONT VIEW

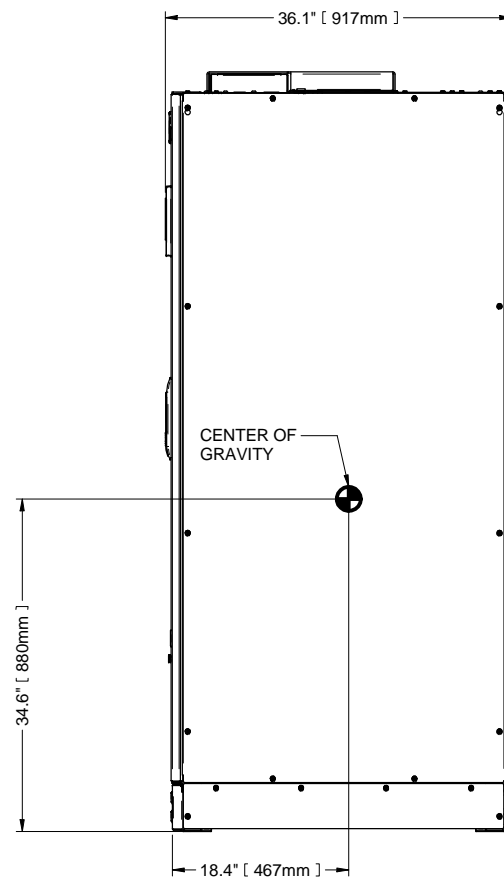

RIGHT SIDE VIEW

SHEET NO. 6 OF 6	DRAWN BY: JASON ZHANG	TITLE  UPS SHIPPING  SMS AND 1+N MULTI-MODULE, 500kVA-600kVA UPS, 480V, WITH BFD, SHARING INDUCTOR AND COMMON MODE CHOKE  LIEBERT EXL S1
ECN NO	DESIGNED BY: JASON ZHANG	
REF DWG.	APPROVED BY:	
REF DWG	S. MAJOR	

DWG. NO. ES1-05-S032	1050 DEARBORN DR P.O. BOX 29186 COLUMBUS, OH 43229
DATE (LATEST REV.) 9/23/2019	
REVISION 0	



NOTES

1. ALL DIMENSIONS ARE IN inches [mm].
2. 24" [610mm] MINIMUM CLEARANCE ABOVE UNIT REQUIRED FOR AIR EXHAUST. 36" [914mm] FRONT ACCESS IS REQUIRED FOR SERVICE.
3. KEEP CABINET WITHIN 15 DEGREES OF VERTICAL.
4. ALL WIRING MUST BE IN ACCORDANCE WITH NATIONAL AND LOCAL ELECTRICAL CODES.
5. UNIT BOTTOM IS STRUCTURALLY ADEQUATE FOR FORKLIFT HANDLING.
6. WIDTH DIMENSIONS INCLUDE SIDE PANELS.

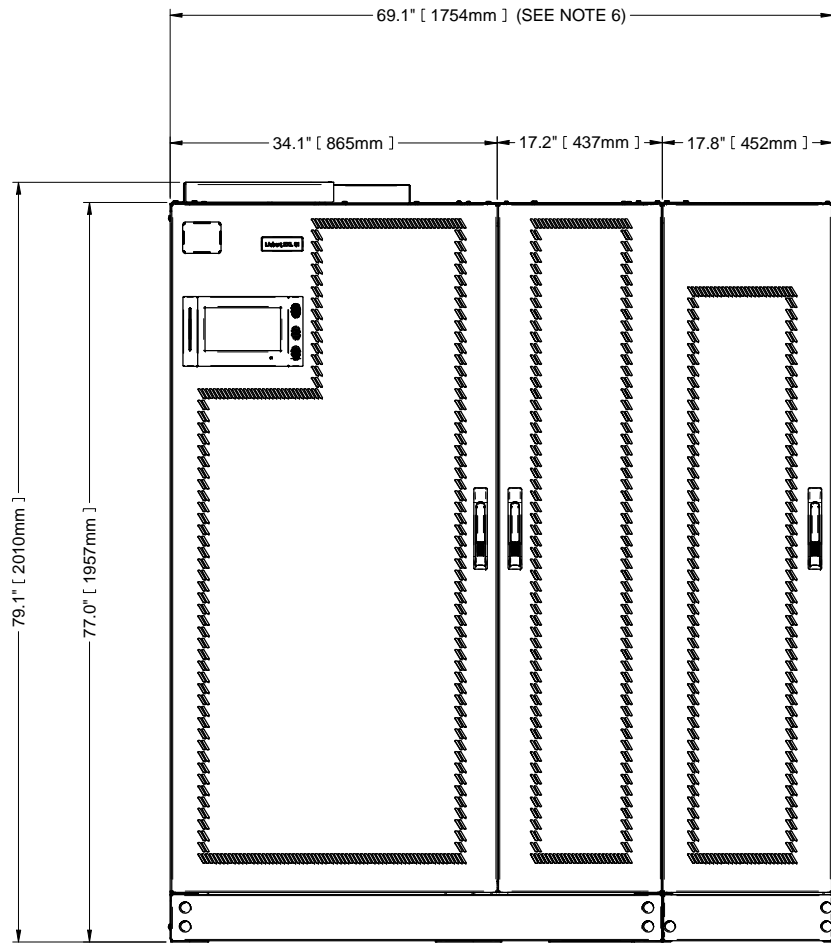

FRONT VIEW

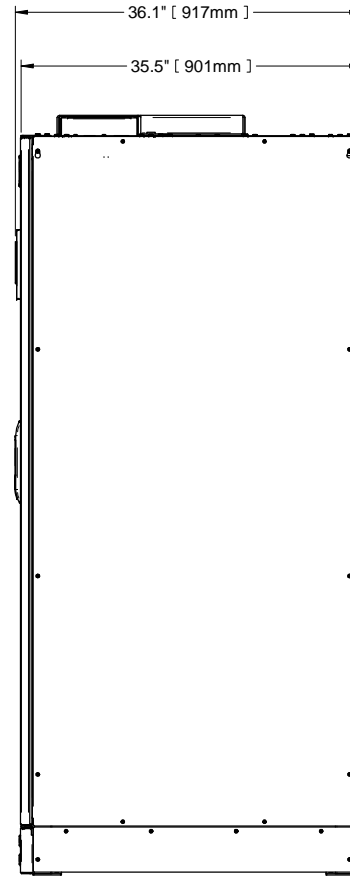

RIGHT SIDE VIEW

SHEET NO. 1 OF 6	DRAWN BY: JASON ZHANG	TITLE  <b>OUTLINE DRAWING SMS AND 1+N MULTI-MODULE, 250kVA-400kVA, 480V WITH COMMON MODE CHOKE LIEBERT EXL S1</b>
ECN NO.	DESIGNED BY: JASON ZHANG	
REF DWG.	APPROVED BY:	
REF DWG	S. MAJOR	

DWG. NO. ES1-05-S033	1050 DEARBORN DR P.O. BOX 29186 COLUMBUS, OH 43229
DATE (LATEST REV.) 1/29/2019	
REVISION 0	



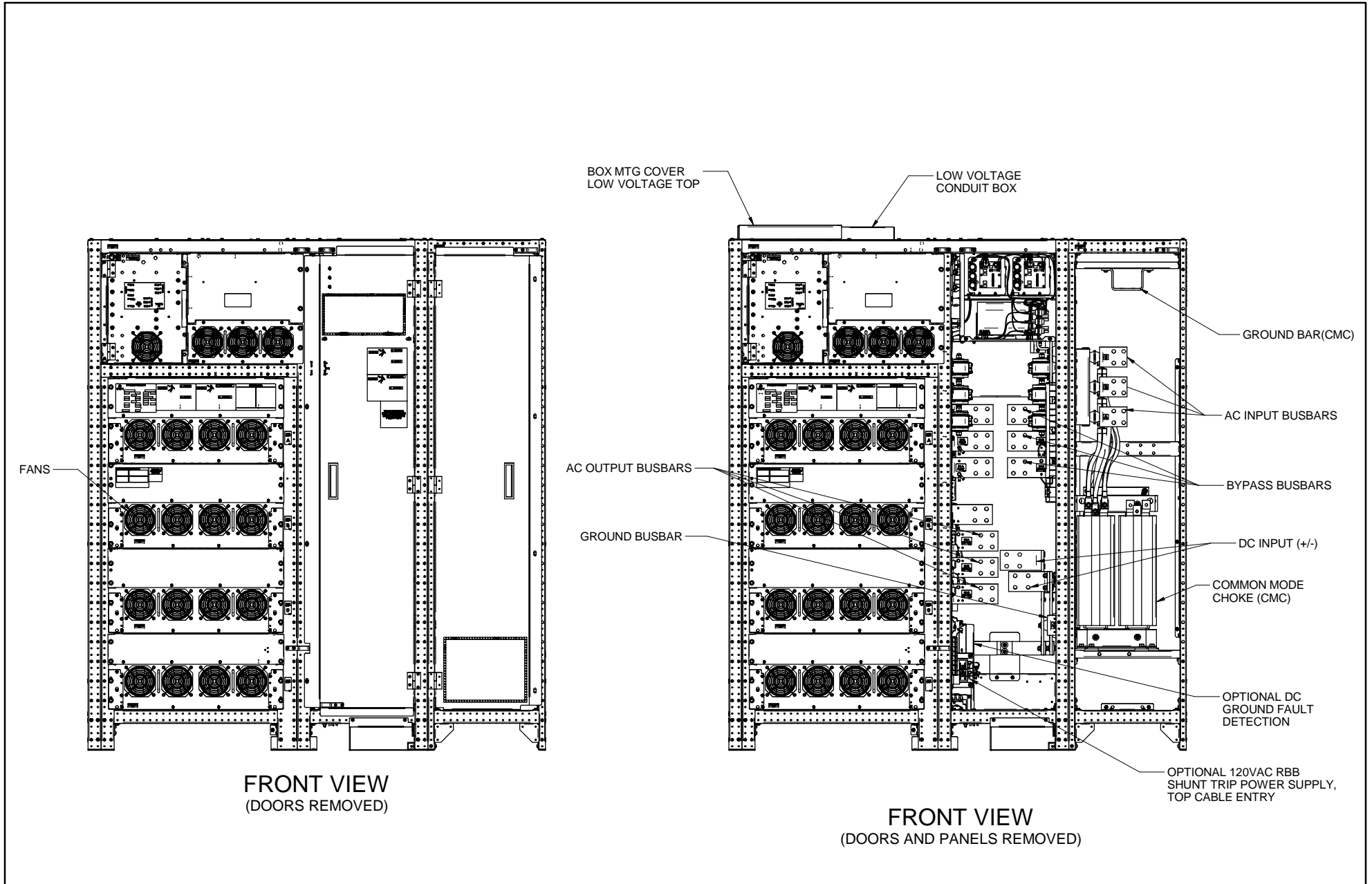

**FRONT VIEW**  
(DOORS REMOVED)

**FRONT VIEW**  
(DOORS AND PANELS REMOVED)

SHEET NO.	DRAWN BY:	TITLE
2 OF 6	JASON ZHANG	<b>MAIN COMPONENTS DRAWING</b> <b>SMS AND 1+N MULTI-MODULE, 250kVA-400kVA, 480V</b> <b>WITH COMMON MODE CHOKE</b> <b>LIEBERT EXL S1</b>
ECN NO.	DESIGNED BY:	
ECN NO	JASON ZHANG	
REF DWG.	APPROVED BY:	
REF DWG	S. MAJOR	

DWG. NO.	ES1-05-S033
DATE (LATEST REV.)	1/29/2019
REVISION	1050 DEARBORN DR P.O. BOX 29186 COLUMBUS, OH 43229
0	



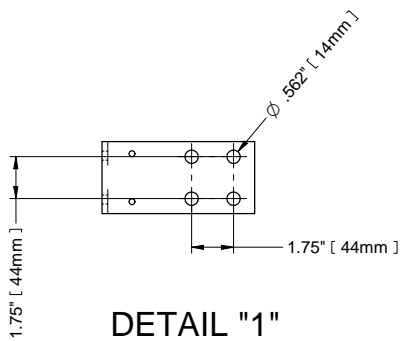

**DETAIL "1"**  
(BYPASS BUSBAR)

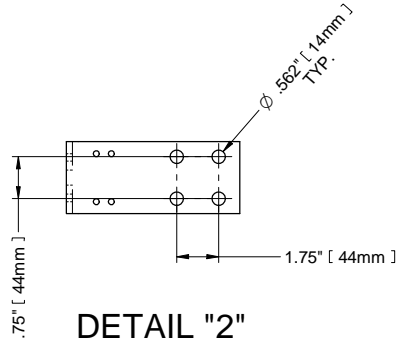

**DETAIL "2"**  
(OUTPUT BUSBAR)

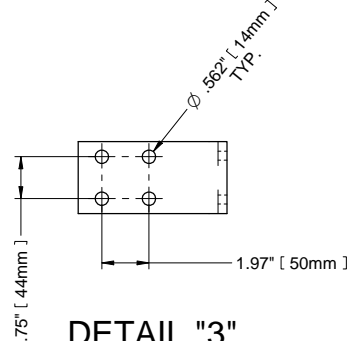

**DETAIL "3"**  
(DC BUSBAR +/-)

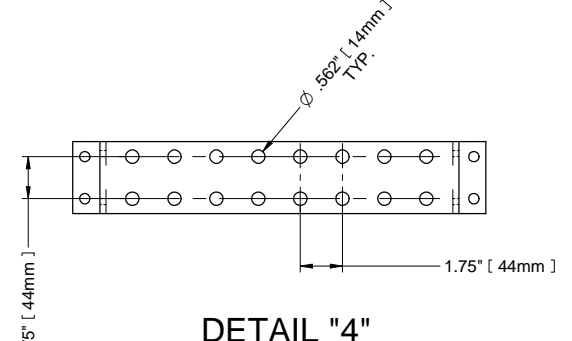

**DETAIL "4"**  
(GROUND BUSBAR)

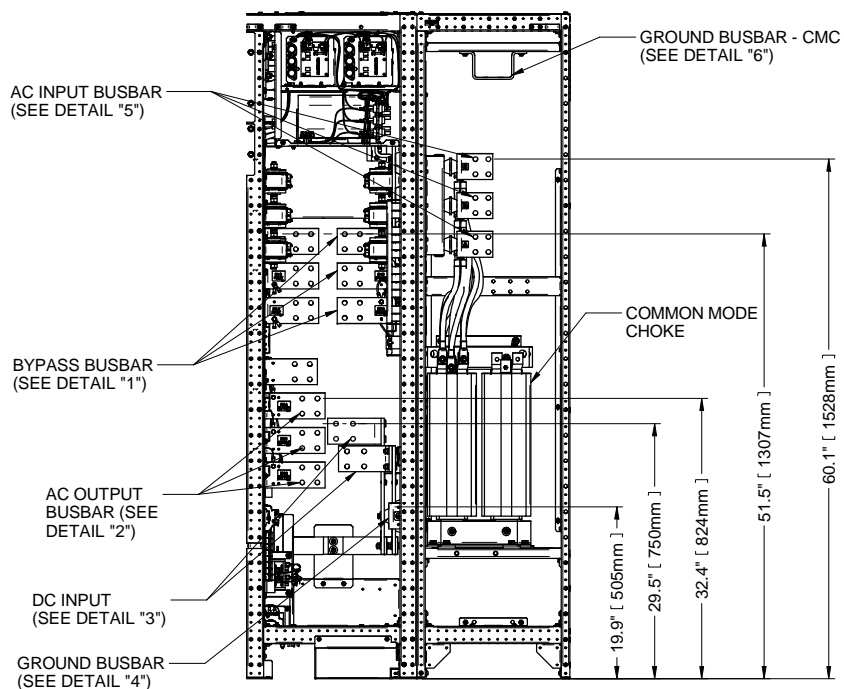

**FRONT VIEW**

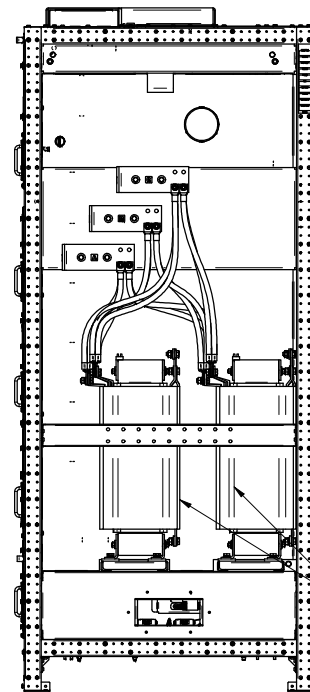

**RIGHT SIDE VIEW**

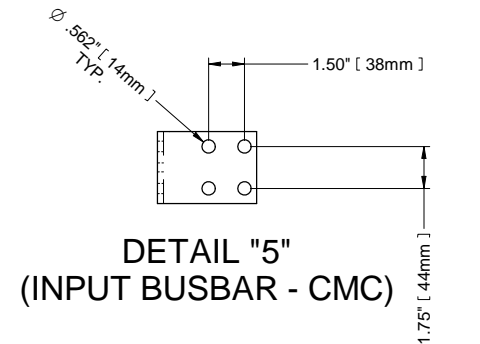

**DETAIL "5"**  
(INPUT BUSBAR - CMC)

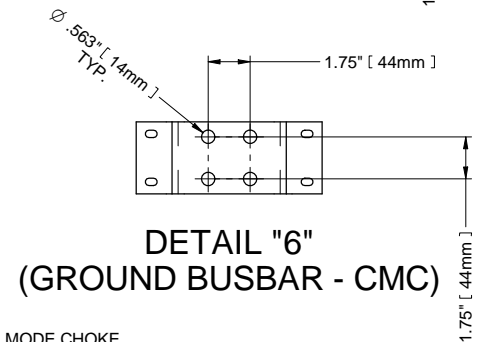

**DETAIL "6"**  
(GROUND BUSBAR - CMC)

**NOTES**

1. ALL DIMENSIONS ARE IN inches [mm].
2. CONTROL AND POWER WIRING MUST BE RUN IN SEPARATE CONDUITS.
3. ALL WIRING MUST BE IN ACCORDANCE WITH NATIONAL AND LOCAL ELECTRICAL CODES.
4. COPPER AND ALUMINUM CABLES ARE ACCEPTABLE

SHEET NO. 3 OF 6	DRAWN BY: JASON ZHANG	TITLE
ECN NO.	DESIGNED BY: JASON ZHANG	<b>UPS ELECTRICAL CONNECTION</b> <b>SMS AND 1+N MULTI-MODULE, 250kVA-400kVA, 480V</b> <b>WITH COMMON MODE CHOKE</b> <b>LIEBERT EXL S1</b>
REF DWG.	APPROVED BY: S. MAJOR	
REF DWG		

DWG. NO. ES1-05-S033
DATE (LATEST REV.) 1/29/2019
REVISION 0
1050 DEARBORN DR P.O. BOX 29186 COLUMBUS, OH 43229



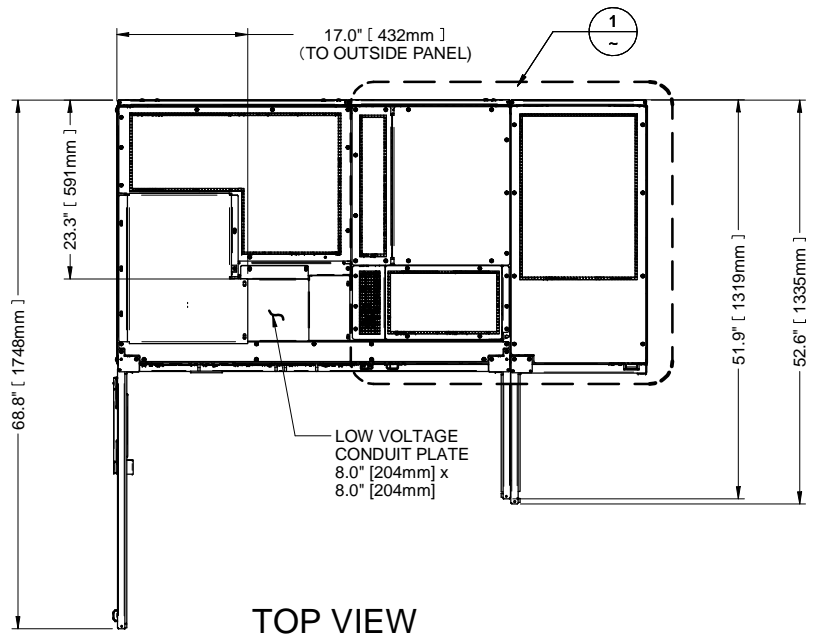

**TOP VIEW**  
(DOORS OPEN)

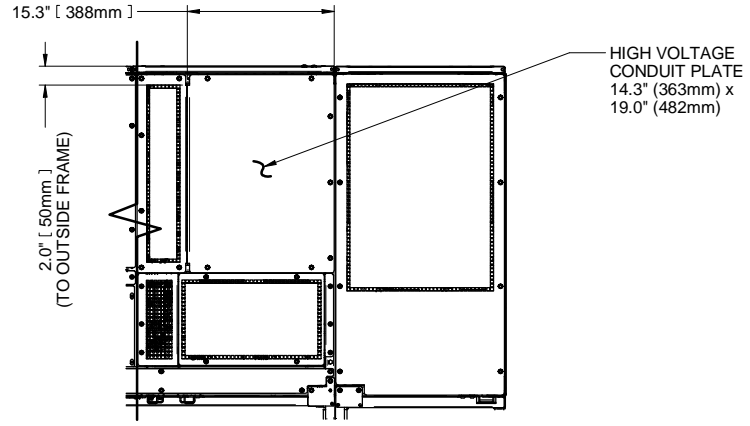

**DETAIL "1"**  
(CABLE ENTRY CONDUIT PLATE)

- NOTES
1. ALL DIMENSIONS ARE IN inches [mm].
  2. UNIT BOTTOM IS STRUCTURALLY ADEQUATE FOR FORKLIFT HANDLING.

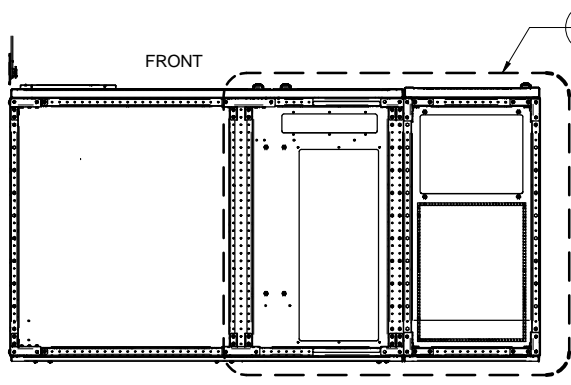

**BOTTOM VIEW**

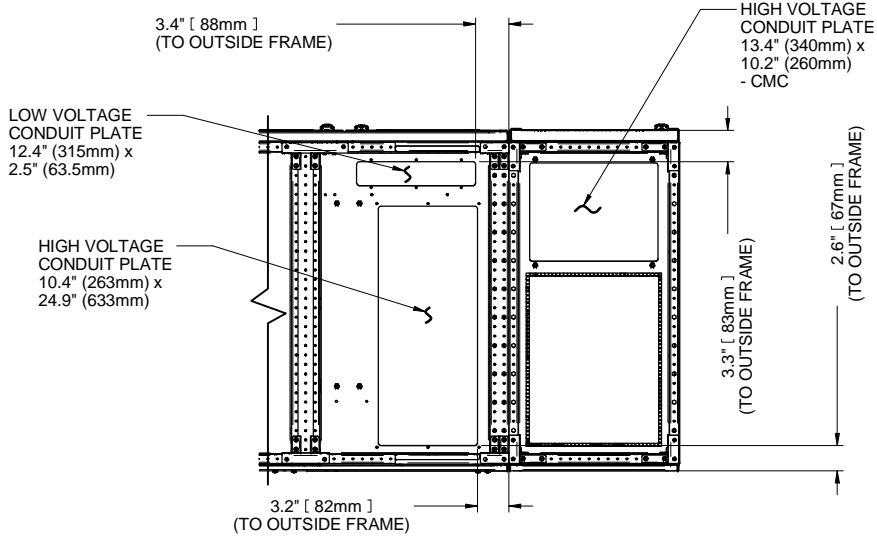

**DETAIL "2"**  
(CABLE ENTRY CONDUIT PLATE)

SHEET NO. 4 OF 6	DRAWN BY: JASON ZHANG	TITLE
ECN NO.	DESIGNED BY: JASON ZHANG	<b>UPS CONDUIT PLATE DETAILS</b> <b>SMS AND 1+N MULTI-MODULE, 250kVA-400kVA, 480V</b> <b>WITH COMMON MODE CHOKE</b> <b>LIEBERT EXL S1</b>
REF DWG.	APPROVED BY:	
REF DWG	S. MAJOR	

DWG. NO. ES1-05-S033
DATE (LATEST REV.) 1/29/2019
REVISION 0
1050 DEARBORN DR P.O. BOX 29186 COLUMBUS, OH 43229



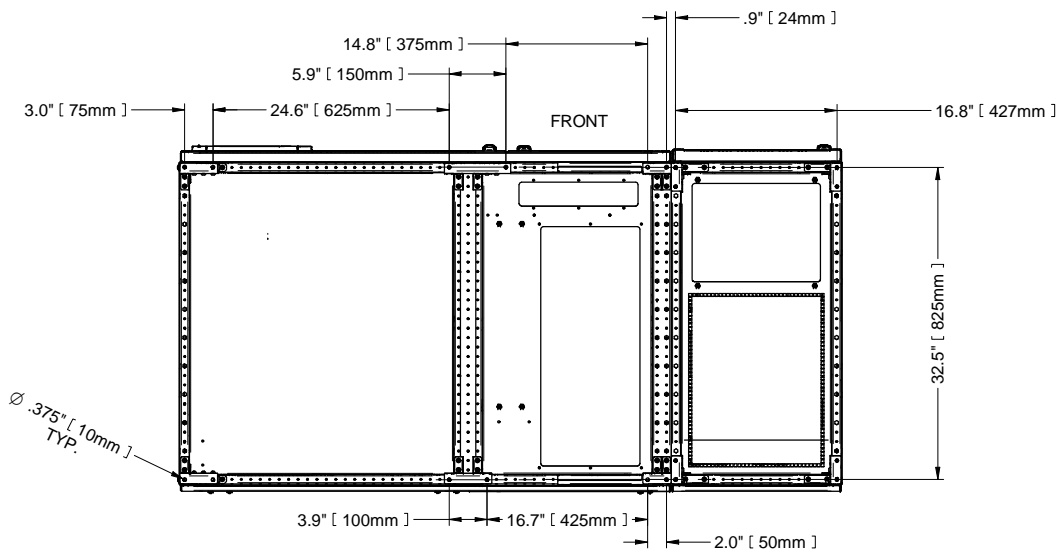

**BOTTOM VIEW**  
(BOLT HOLE LAYOUT)

**NOTES**

1. ALL DIMENSIONS ARE IN inches [mm].
2. UNIT BOTTOM IS STRUCTURALLY ADEQUATE FOR FORKLIFT HANDLING.

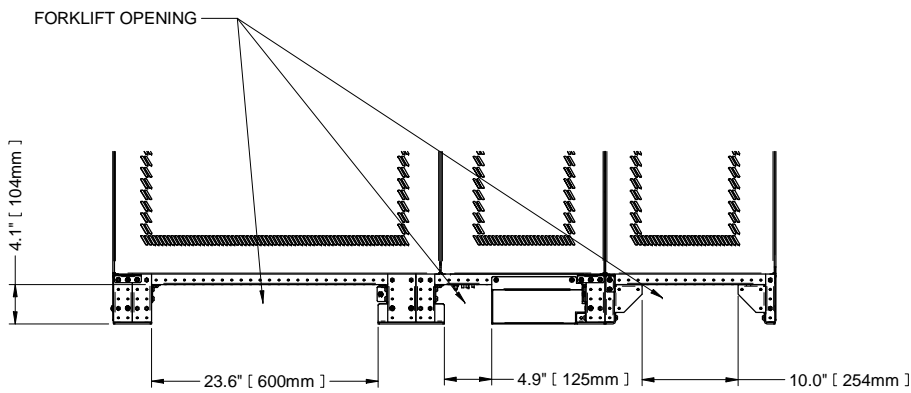

**FRONT VIEW**

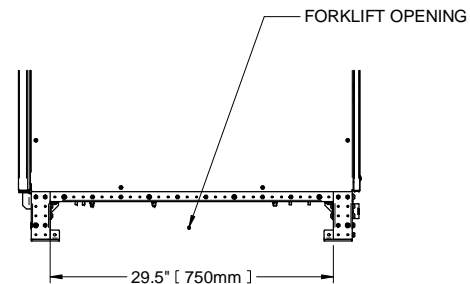

**RIGHT SIDE VIEW**

SHEET NO. 5 OF 6	DRAWN BY: JASON ZHANG	<b>TITLE</b>  <b>UPS BASE DRAWING</b> <b>SMS AND 1+N MULTI-MODULE, 250kVA-400kVA, 480V</b> <b>WITH COMMON MODE CHOKE</b> <b>LIEBERT EXL S1</b>
ECN NO.	DESIGNED BY: JASON ZHANG	
REF DWG.	APPROVED BY:	
REF DWG	S. MAJOR	

DWG. NO. ES1-05-S033	 <b>VERTIV™</b>
DATE (LATEST REV.) 1/29/2019	
REVISION 0	1050 DEARBORN DR P.O. BOX 29186 COLUMBUS, OH 43229



NOTES

1. ALL DIMENSIONS ARE IN inches [mm].

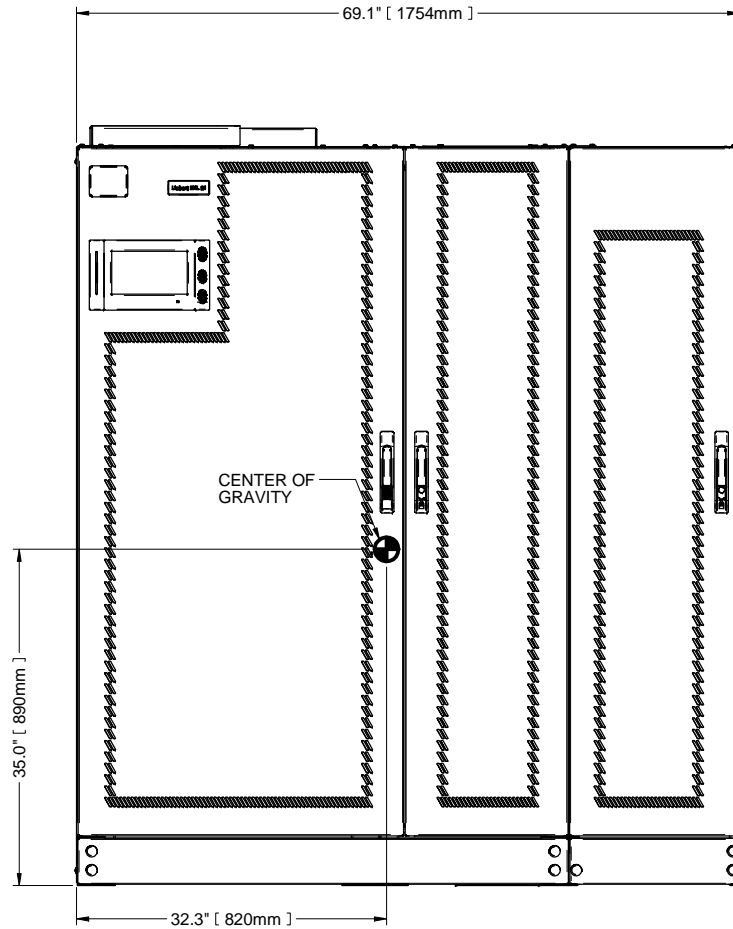

FRONT VIEW

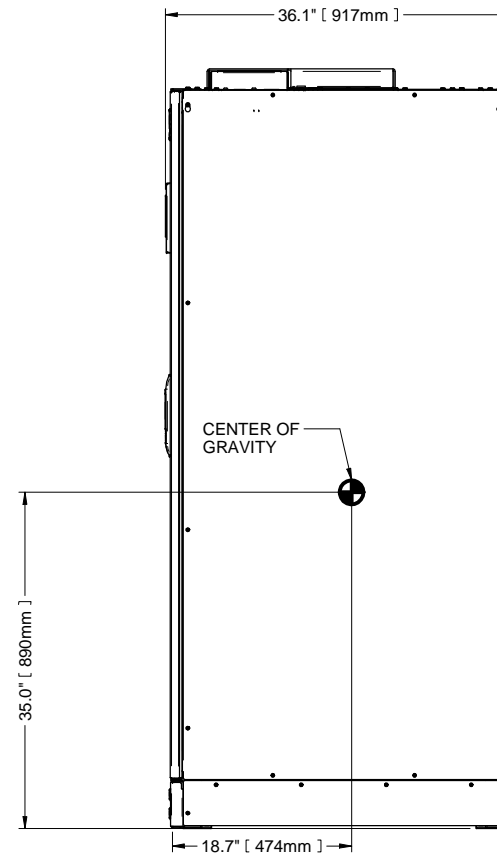

RIGHT SIDE VIEW

SHEET NO. 6 OF 6	DRAWN BY: JASON ZHANG	TITLE  UPS SHIPPING SMS AND 1+N MULTI-MODULE, 250kVA-400kVA, 480V WITH COMMON MODE CHOKE LIEBERT EXL S1
ECN NO	DESIGNED BY: JASON ZHANG	
REF DWG.	APPROVED BY:	
REF DWG	S. MAJOR	

DWG. NO. ES1-05-S033	1050 DEARBORN DR P.O. BOX 29186 COLUMBUS, OH 43229
DATE (LATEST REV.) 1/29/2019	
REVISION 0	



NOTES

1. ALL DIMENSIONS ARE IN inches [mm].
2. 24" [610mm] MINIMUM CLEARANCE ABOVE UNIT REQUIRED FOR AIR EXHAUST. 36" [914mm] FRONT ACCESS IS REQUIRED FOR SERVICE.
3. KEEP CABINET WITHIN 15 DEGREES OF VERTICAL.
4. ALL WIRING MUST BE IN ACCORDANCE WITH NATIONAL AND LOCAL ELECTRICAL CODES.
5. UNIT BOTTOM IS STRUCTURALLY ADEQUATE FOR FORKLIFT HANDLING.
6. WIDTH DIMENSIONS INCLUDE SIDE PANELS.

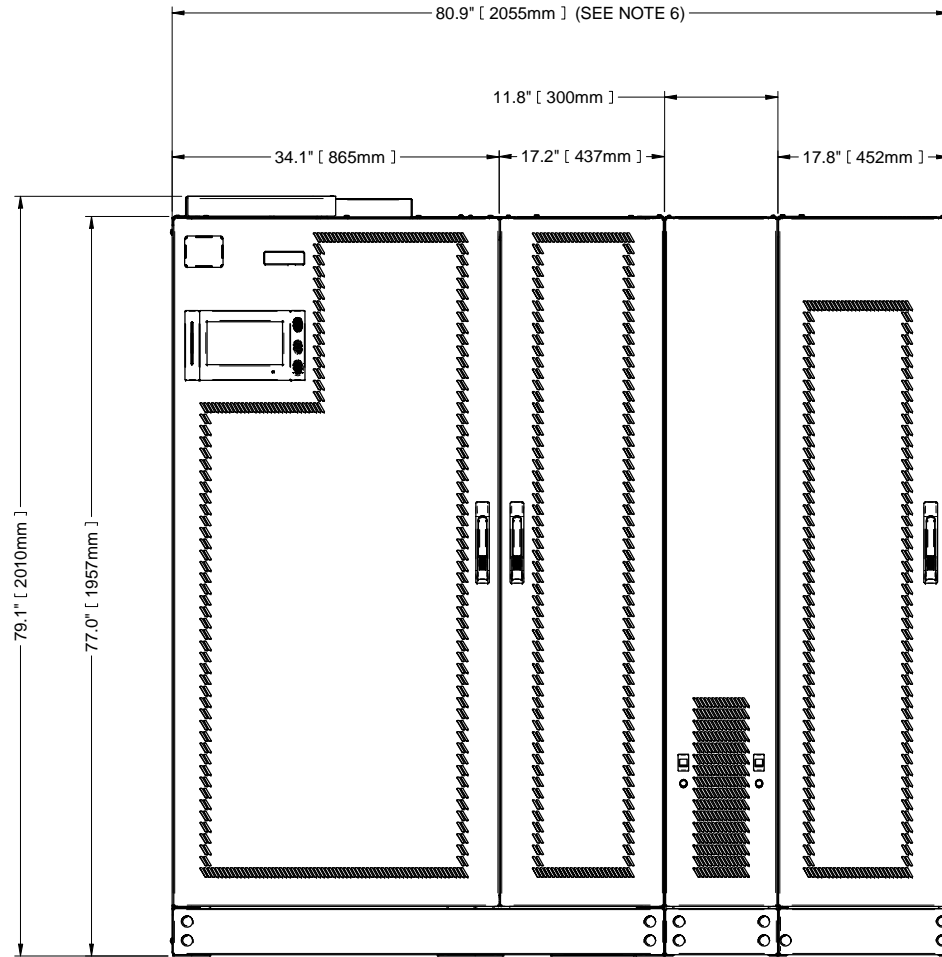

FRONT VIEW

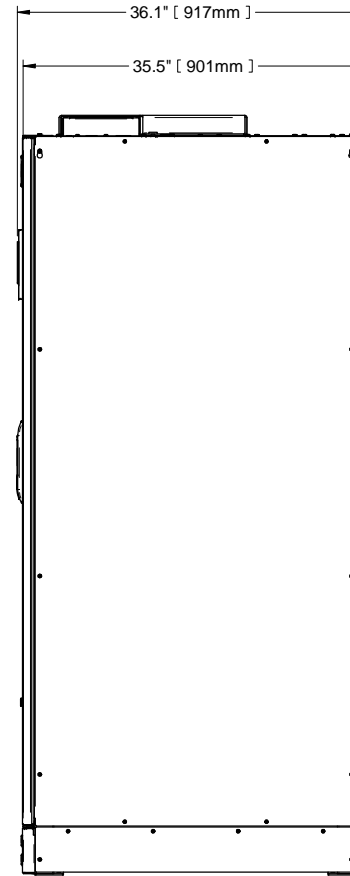

RIGHT SIDE VIEW

SHEET NO. 1 OF 6	DRAWN BY: JASON ZHANG
ECN NO.	DESIGNED BY: JASON ZHANG
REF DWG.	APPROVED BY: S. MAJOR

TITLE <b>OUTLINE DRAWING</b> SMS AND 1+N MULTI-MODULE, 250kVA-400kVA UPS, 480V, WITH BFD AND COMMON MODE CHOKE LIEBERT EXL S1
---

DWG. NO. ES1-05-S034
DATE (LATEST REV.) 1/29/2019
REVISION 0
1050 DEARBORN DR P.O. BOX 29186 COLUMBUS, OH 43229



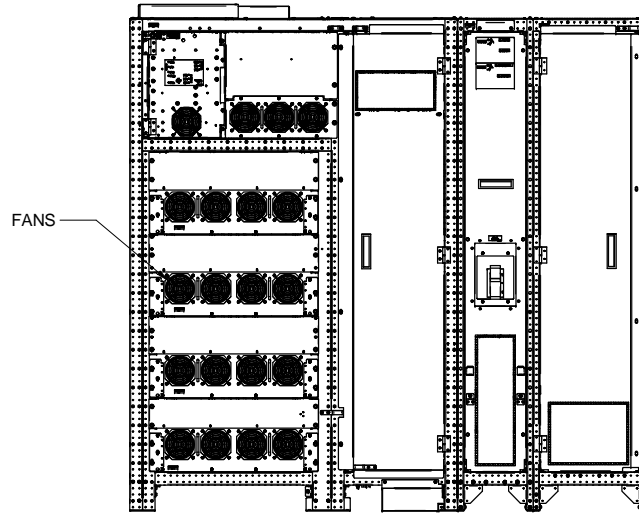

**FRONT VIEW**  
(DOORS REMOVED)

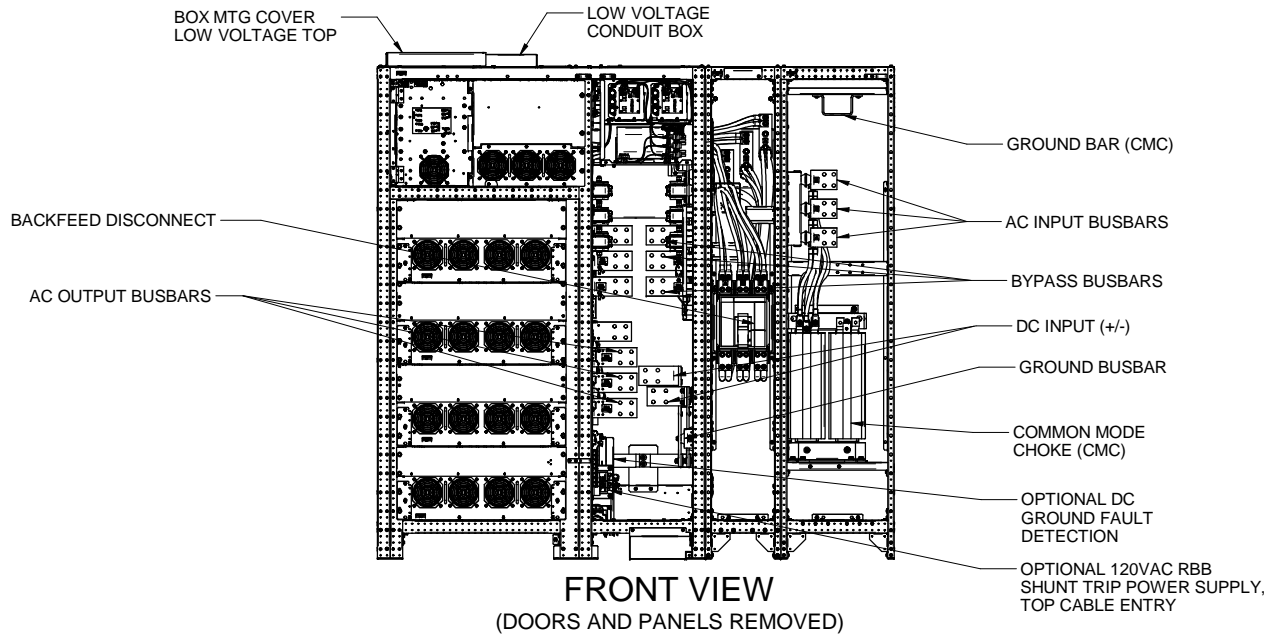

**FRONT VIEW**  
(DOORS AND PANELS REMOVED)

SHEET NO. 2 OF 6	DRAWN BY: JASON ZHANG	TITLE
ECN NO.	DESIGNED BY: JASON ZHANG	<p style="text-align: center;"><b>MAIN COMPONENTS DRAWING</b></p> <p style="text-align: center;"><b>SMS AND 1+N MULTI-MODULE, 250kVA-400kVA UPS, 480V, WITH BFD AND COMMON MODE CHOKE</b></p> <p style="text-align: center;"><b>LIEBERT EXL S1</b></p>
ECN NO	APPROVED BY: S. MAJOR	
REF DWG.		

DWG. NO. ES1-05-S034	
DATE (LATEST REV.) 1/29/2019	
REVISION 0	1050 DEARBORN DR P.O. BOX 29186 COLUMBUS, OH 43229

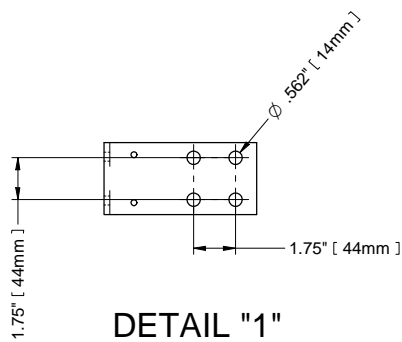

**DETAIL "1"**  
(BYPASS BUSBAR)

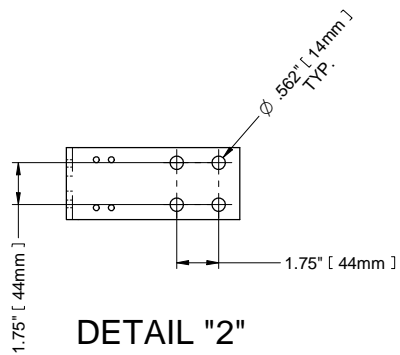

**DETAIL "2"**  
(OUTPUT BUSBAR)

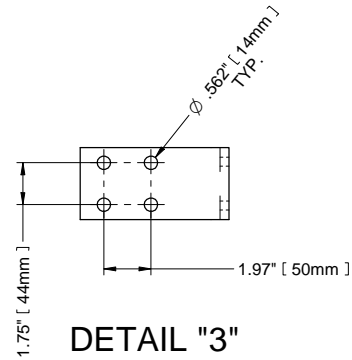

**DETAIL "3"**  
(DC BUSBAR +/-)

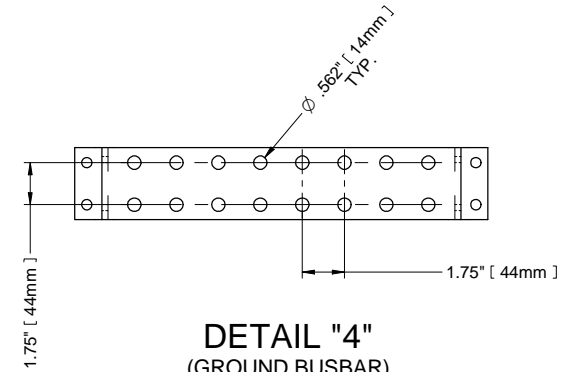

**DETAIL "4"**  
(GROUND BUSBAR)

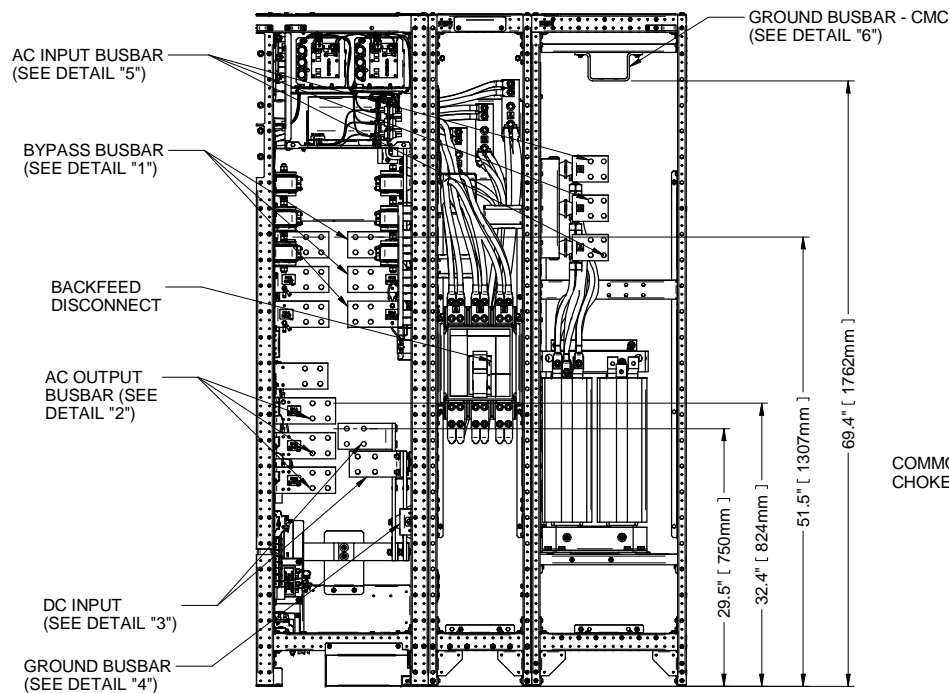

**FRONT VIEW**

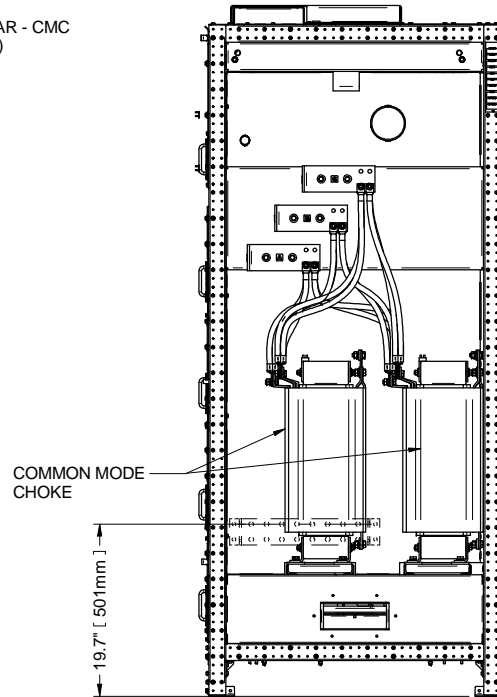

**RIGHT SIDE VIEW**

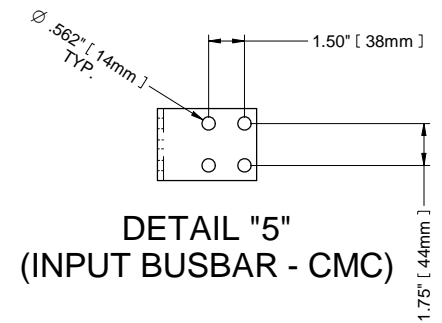

**DETAIL "5"**  
(INPUT BUSBAR - CMC)

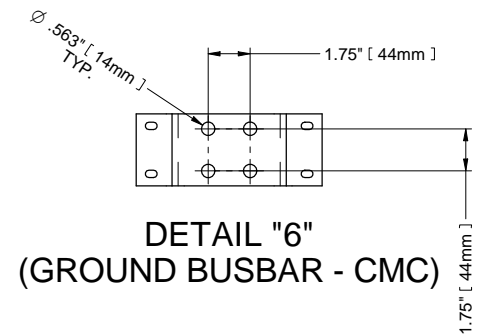

**DETAIL "6"**  
(GROUND BUSBAR - CMC)

**NOTES**

1. ALL DIMENSIONS ARE IN inches [mm].
2. CONTROL AND POWER WIRING MUST BE RUN IN SEPARATE CONDUITS.
3. ALL WIRING MUST BE IN ACCORDANCE WITH NATIONAL AND LOCAL ELECTRICAL CODES.
4. COPPER AND ALUMINUM CABLES ARE ACCEPTABLE

SHEET NO. 3 OF 6	DRAWN BY: JASON ZHANG	TITLE
ECN NO.	DESIGNED BY: JASON ZHANG	<b>UPS ELECTRICAL CONNECTION</b> <b>SMS AND 1+N MULTI-MODULE, 250kVA-400kVA UPS, 480V,</b> <b>WITH BFD AND COMMON MODE CHOKE</b> <b>LIEBERT EXL S1</b>
REF DWG.	APPROVED BY: S. MAJOR	
REF DWG		

DWG. NO. ES1-05-S034
DATE (LATEST REV.) 1/29/2019
REVISION 0
1050 DEARBORN DR P.O. BOX 29186 COLUMBUS, OH 43229



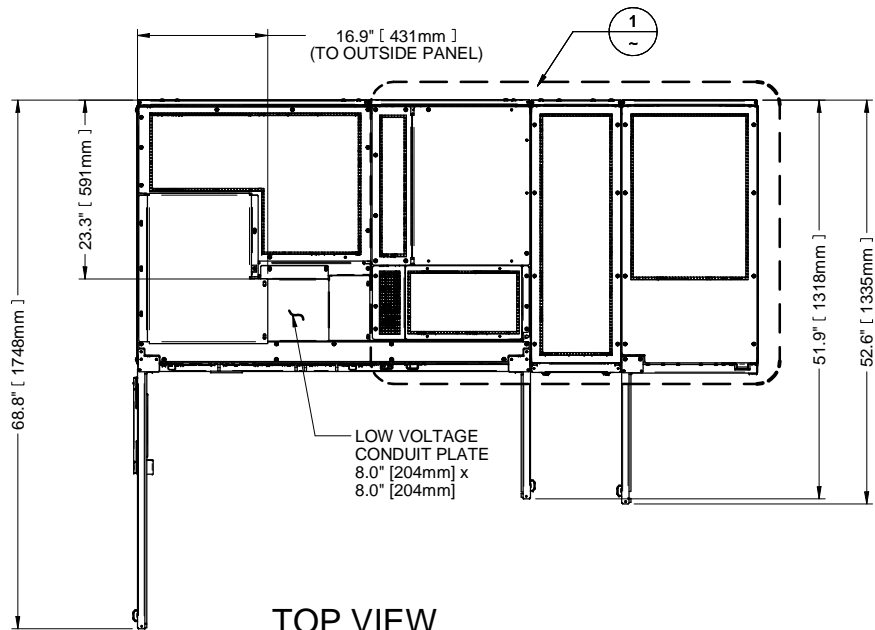

**TOP VIEW**  
(DOORS OPEN)

R. 1" [30mm]

FRONT

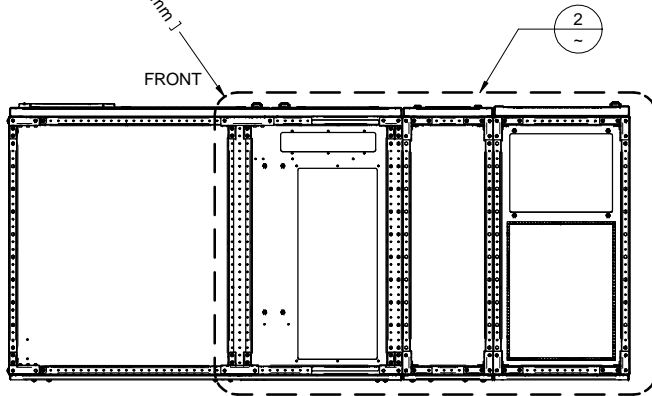

**BOTTOM VIEW**

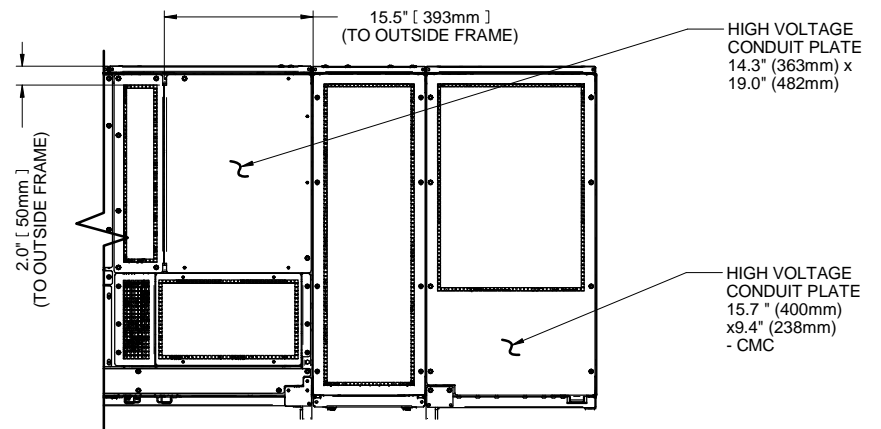

**DETAIL "1"**  
(CABLE ENTRY CONDUIT PLATE)

**NOTES**

1. ALL DIMENSIONS ARE IN inches [mm].
2. UNIT BOTTOM IS STRUCTURALLY ADEQUATE FOR FORKLIFT HANDLING.

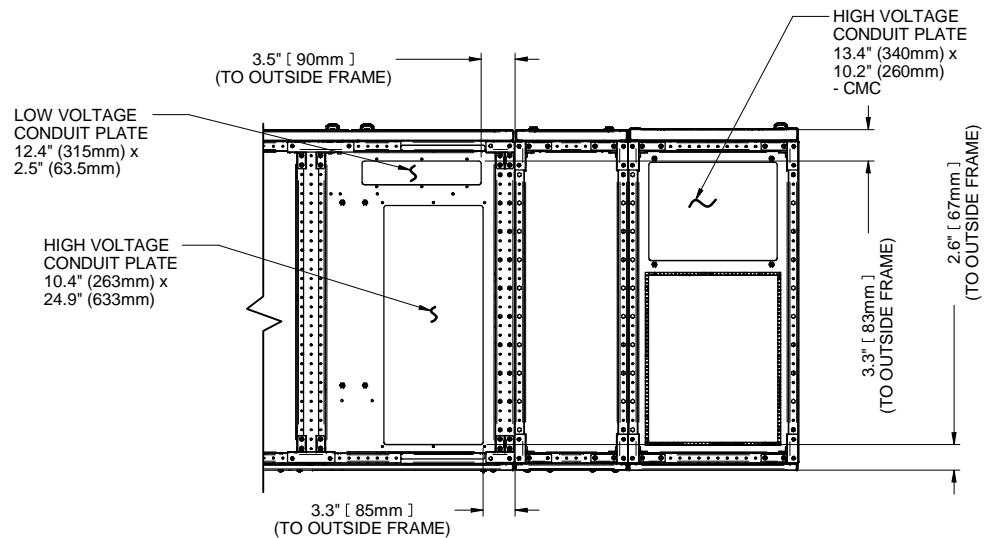

**DETAIL "2"**  
(CABLE ENTRY CONDUIT PLATE)

SHEET NO. 4 OF 6	DRAWN BY: JASON ZHANG	TITLE
ECN NO.	DESIGNED BY: JASON ZHANG	<b>UPS CONDUIT PLATE DETAILS</b> <b>SMS AND 1+N MULTI-MODULE, 250kVA-400kVA UPS, 480V,</b> <b>WITH BFD AND COMMON MODE CHOKE</b> <b>LIEBERT EXL S1</b>
REF DWG.	APPROVED BY: S. MAJOR	
REF DWG		

DWG. NO. ES1-05-S034	
DATE (LATEST REV.) 1/29/2019	
REVISION 0	1050 DEARBORN DR P.O. BOX 29186 COLUMBUS, OH 43229

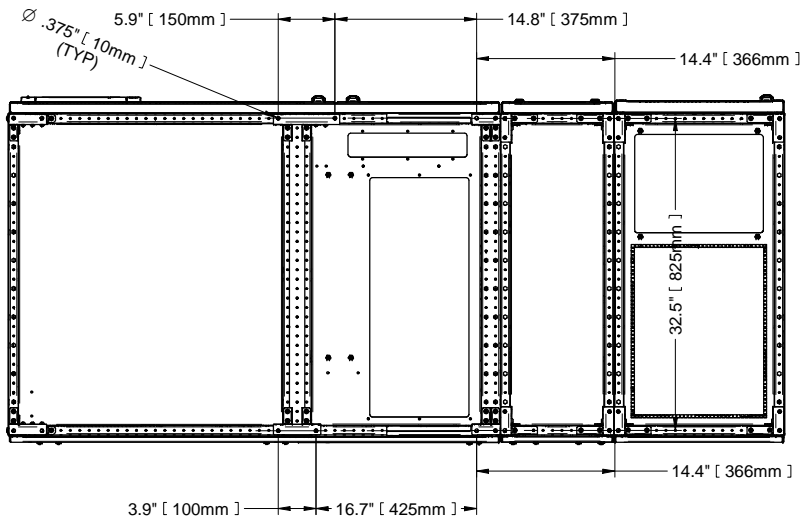

**BOTTOM VIEW**  
(BOLT HOLE LAYOUT)

**NOTES**

1. ALL DIMENSIONS ARE IN inches [mm].
2. UNIT BOTTOM IS STRUCTURALLY ADEQUATE FOR FORKLIFT HANDLING.

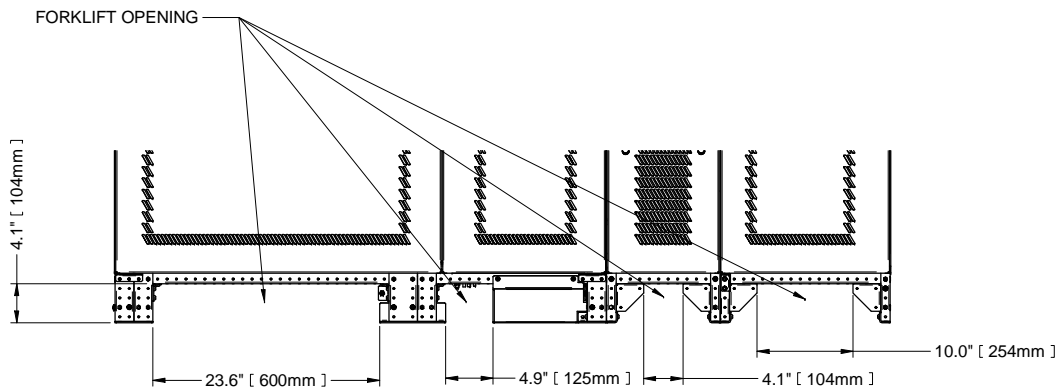

**FRONT VIEW**

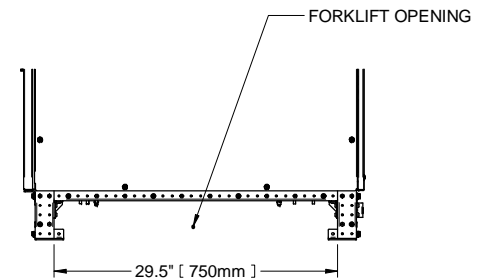

**RIGHT SIDE VIEW**

SHEET NO. 5 OF 6	DRAWN BY: JASON ZHANG	TITLE  <b>UPS BASE DRAWING</b> <b>SMS AND 1+N MULTI-MODULE, 250kVA-400kVA UPS, 480V,</b> <b>WITH BFD AND COMMON MODE CHOKE</b> <b>LIEBERT EXL S1</b>
ECN NO.	DESIGNED BY: JASON ZHANG	
REF DWG.	APPROVED BY:	
REF DWG	S. MAJOR	

DWG. NO. ES1-05-S034	1050 DEARBORN DR P.O. BOX 29186 COLUMBUS, OH 43229
DATE (LATEST REV.) 1/29/2019	
REVISION 0	



NOTES

1. ALL DIMENSIONS ARE IN inches [mm].

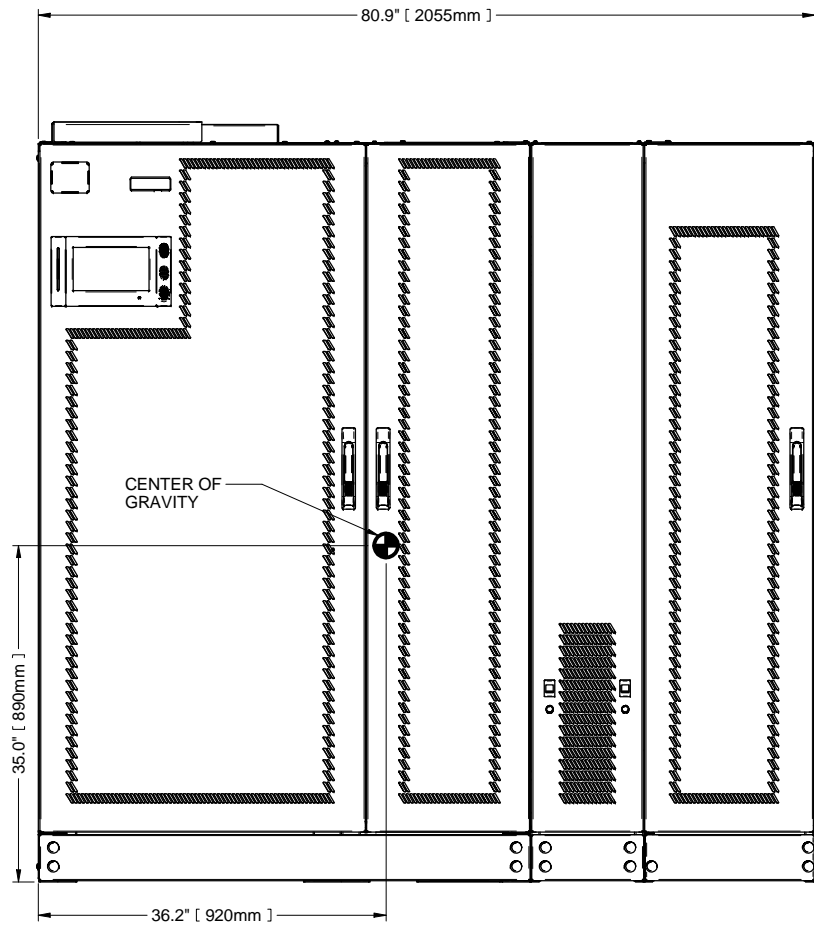

FRONT VIEW

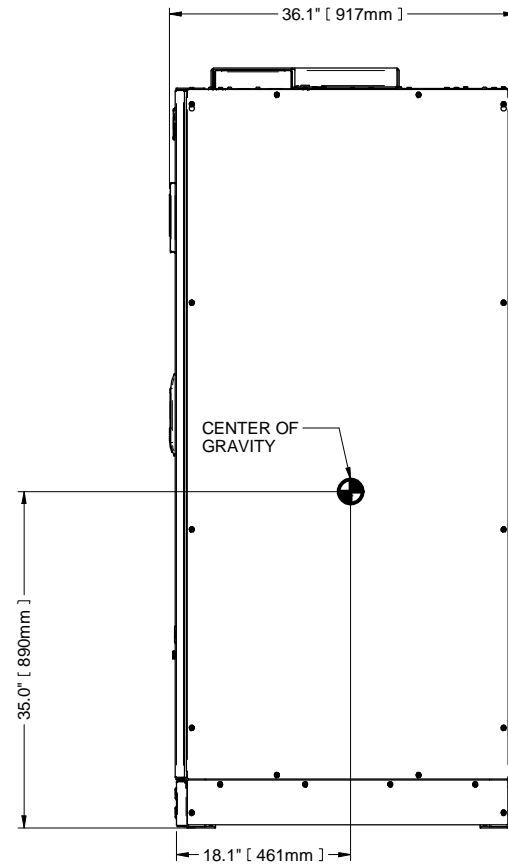

RIGHT SIDE VIEW

SHEET NO. 6 OF 6	DRAWN BY: JASON ZHANG	TITLE  UPS SHIPPING SMS AND 1+N MULTI-MODULE, 250kVA-400kVA UPS, 480V, WITH BFD AND COMMON MODE CHOKE LIEBERT EXL S1
ECN NO	DESIGNED BY: JASON ZHANG	
REF DWG.	APPROVED BY:	
REF DWG	S. MAJOR	

DWG. NO. ES1-05-S034
DATE (LATEST REV.) 1/29/2019
REVISION 0
1050 DEARBORN DR P.O. BOX 29186 COLUMBUS, OH 43229



NOTES

1. ALL DIMENSIONS ARE IN inches [mm].
2. 24" [610mm] MINIMUM CLEARANCE ABOVE UNIT REQUIRED FOR AIR EXHAUST. 36" [914mm] FRONT ACCESS IS REQUIRED FOR SERVICE.
3. KEEP CABINET WITHIN 15 DEGREES OF VERTICAL.
4. ALL WIRING MUST BE IN ACCORDANCE WITH NATIONAL AND LOCAL ELECTRICAL CODES.
5. UNIT BOTTOM IS STRUCTURALLY ADEQUATE FOR FORKLIFT HANDLING.
6. WIDTH DIMENSIONS INCLUDE SIDE PANELS.

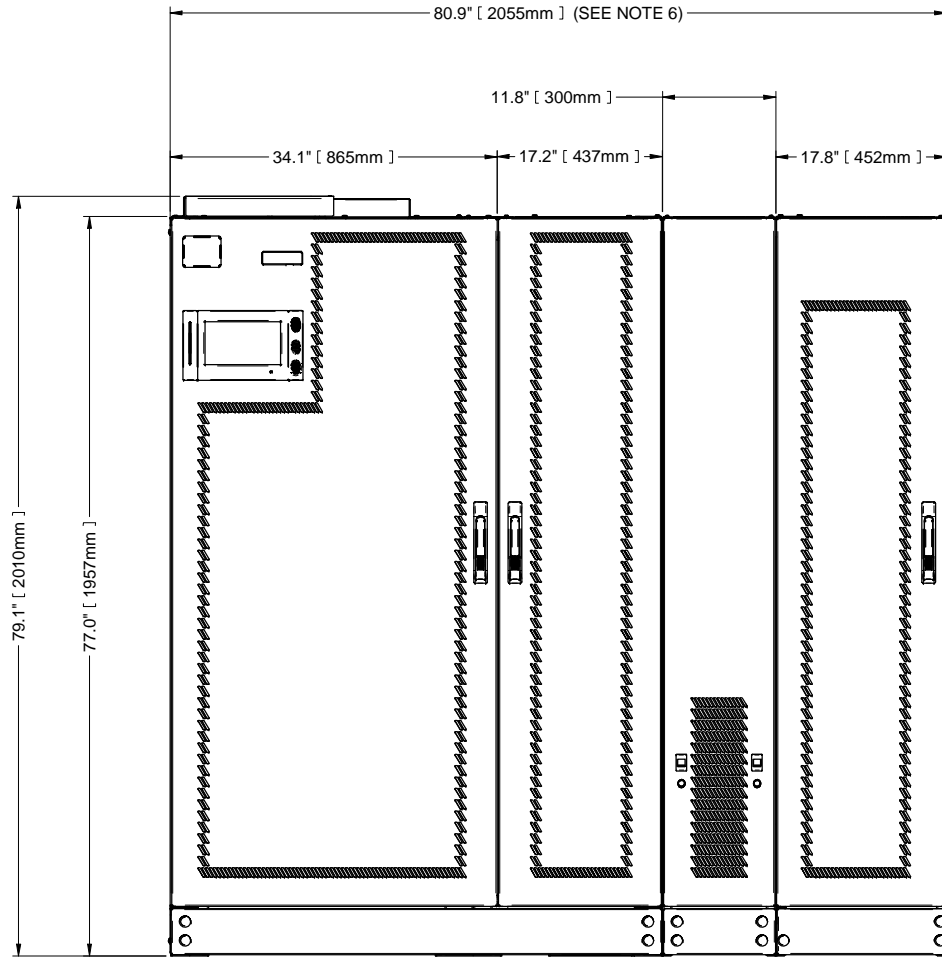

FRONT VIEW

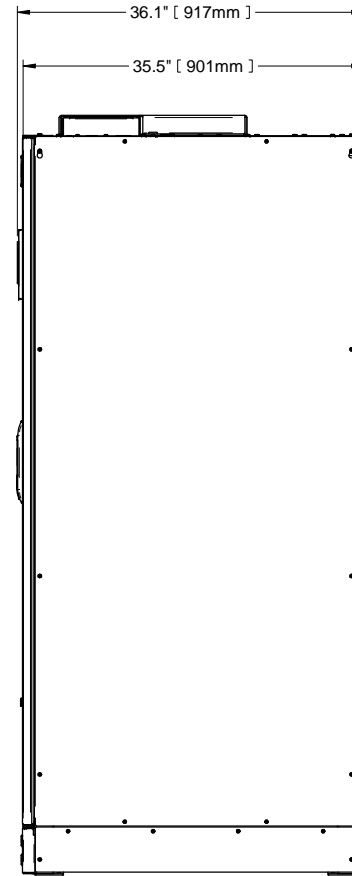

RIGHT SIDE VIEW

SHEET NO. 1 OF 6	DRAWN BY: JASON ZHANG	TITLE  OUTLINE DRAWING SMS AND 1+N MULTI-MODULE, 250kVA-400kVA UPS, 480V, WITH SHARING INDUCTOR AND COMMON MODE CHOKE LIEBERT EXL S1
ECN NO.	DESIGNED BY: JASON ZHANG	
REF DWG.	APPROVED BY:	
REF DWG	S. MAJOR	

DWG. NO. ES1-05-S035	DATE (LATEST REV.) 1/29/2019
REVISION 0	





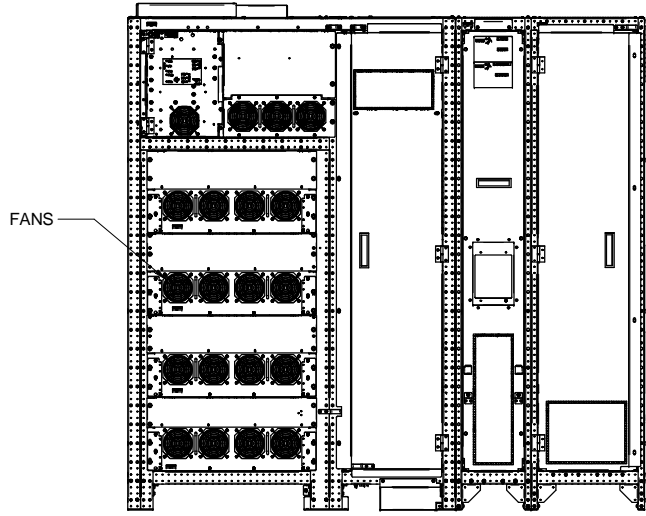

FANS

**FRONT VIEW**  
(DOORS REMOVED)

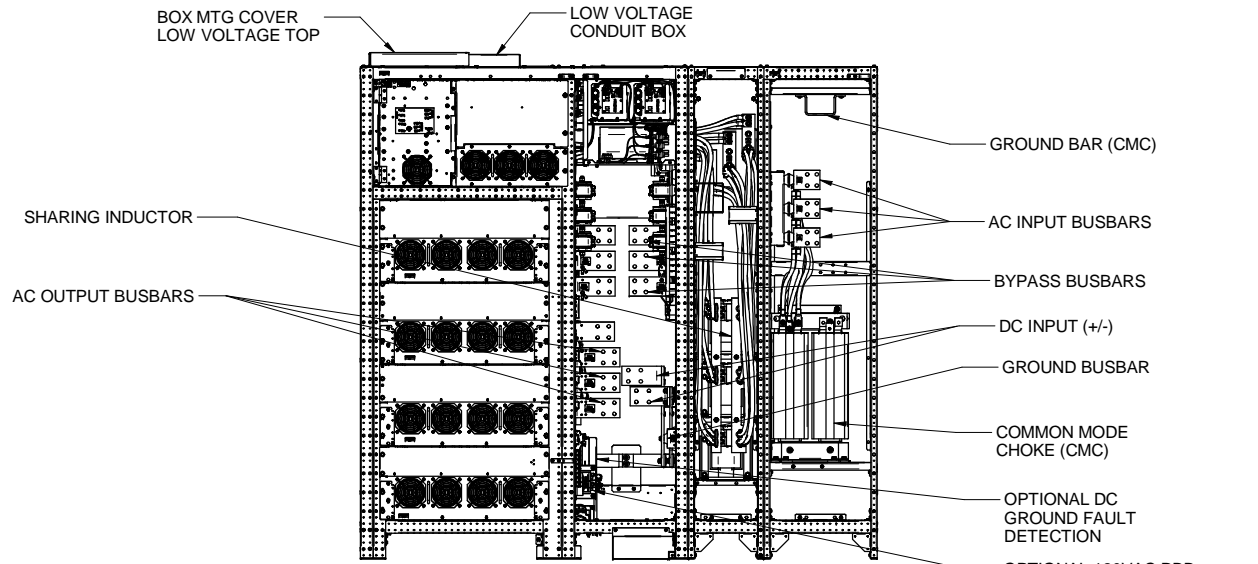

BOX MTG COVER  
LOW VOLTAGE TOP

LOW VOLTAGE  
CONDUIT BOX

SHARING INDUCTOR

AC OUTPUT BUSBARS

GROUND BAR (CMC)

AC INPUT BUSBARS

BYPASS BUSBARS

DC INPUT (+/-)

GROUND BUSBAR

COMMON MODE  
CHOKE (CMC)

OPTIONAL DC  
GROUND FAULT  
DETECTION

OPTIONAL 120VAC RBB  
SHUNT TRIP POWER SUPPLY,  
TOP CABLE ENTRY

**FRONT VIEW**  
(DOORS AND PANELS REMOVED)

SHEET NO. 2 OF 6	DRAWN BY: JASON ZHANG	TITLE  <b>MAIN COMPONENTS DRAWING</b> <b>SMS AND 1+N MULTI-MODULE, 250kVA-400kVA UPS, 480V,</b> <b>WITH SHARING INDUCTOR AND COMMON MODE CHOKE</b> <b>LIEBERT EXL S1</b>
ECN NO.	DESIGNED BY: JASON ZHANG	
ECN NO	APPROVED BY: S. MAJOR	
REF DWG. REF DWG		

DWG. NO. ES1-05-S035	
DATE (LATEST REV.) 1/29/2019	
REVISION 0	1050 DEARBORN DR P.O. BOX 29186 COLUMBUS, OH 43229

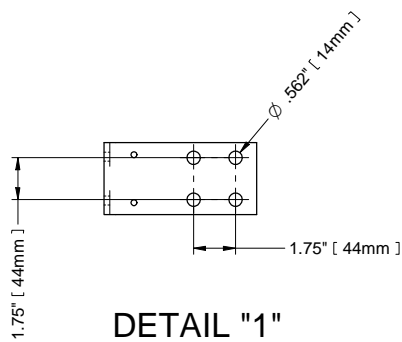

**DETAIL "1"**  
(BYPASS BUSBAR)

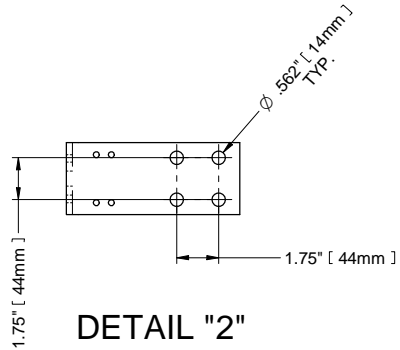

**DETAIL "2"**  
(OUTPUT BUSBAR)

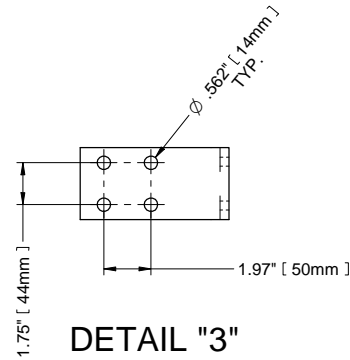

**DETAIL "3"**  
(DC BUSBAR +/-)

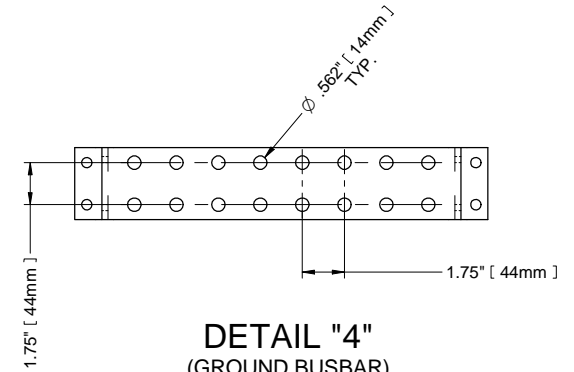

**DETAIL "4"**  
(GROUND BUSBAR)

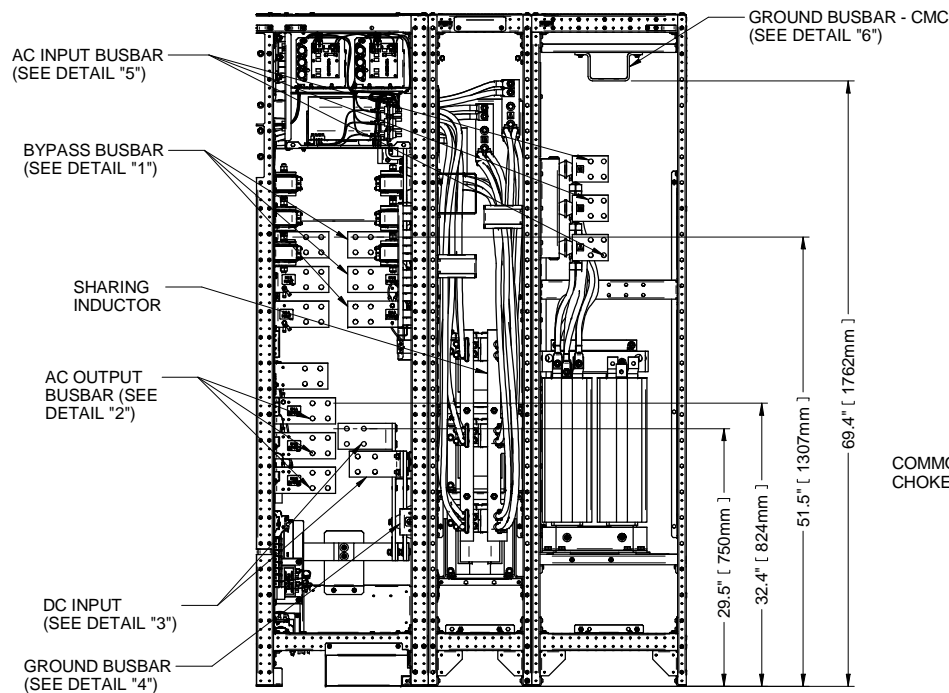

**FRONT VIEW**

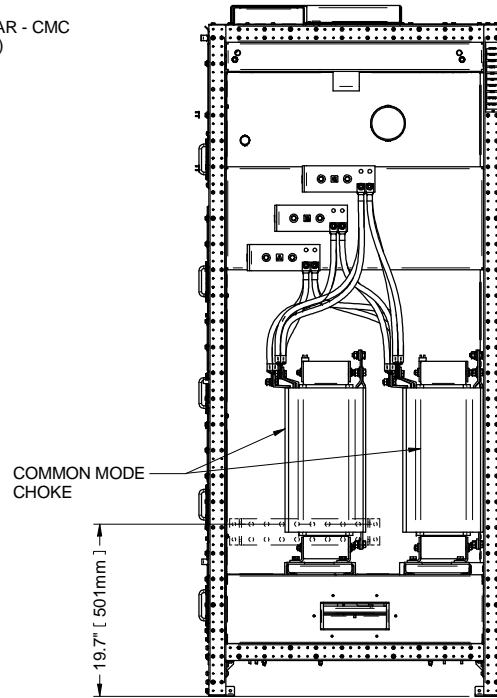

**RIGHT SIDE VIEW**

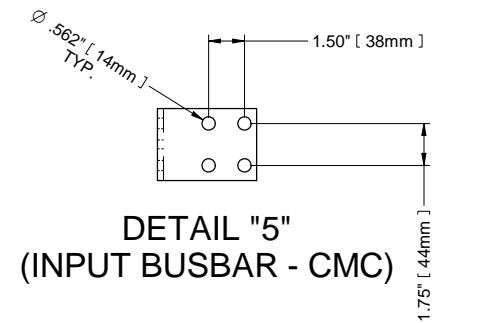

**DETAIL "5"**  
(INPUT BUSBAR - CMC)

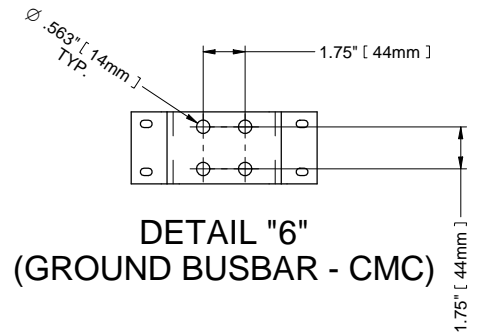

**DETAIL "6"**  
(GROUND BUSBAR - CMC)

**NOTES**

1. ALL DIMENSIONS ARE IN inches [mm].
2. CONTROL AND POWER WIRING MUST BE RUN IN SEPARATE CONDUITS.
3. ALL WIRING MUST BE IN ACCORDANCE WITH NATIONAL AND LOCAL ELECTRICAL CODES.
4. COPPER AND ALUMINUM CABLES ARE ACCEPTABLE

SHEET NO. 3 OF 6	DRAWN BY: JASON ZHANG	TITLE
ECN NO.	DESIGNED BY: JASON ZHANG	<b>UPS ELECTRICAL CONNECTION</b> <b>SMS AND 1+N MULTI-MODULE, 250kVA-400kVA UPS, 480V,</b> <b>WITH SHARING INDUCTOR AND COMMON MODE CHOKE</b> <b>LIEBERT EXL S1</b>
REF DWG.	APPROVED BY: S. MAJOR	
REF DWG		

**UPS ELECTRICAL CONNECTION**  
**SMS AND 1+N MULTI-MODULE, 250kVA-400kVA UPS, 480V,**  
**WITH SHARING INDUCTOR AND COMMON MODE CHOKE**  
**LIEBERT EXL S1**

DWG. NO. ES1-05-S035
DATE (LATEST REV.) 1/29/2019
REVISION 0
1050 DEARBORN DR P.O. BOX 29186 COLUMBUS, OH 43229



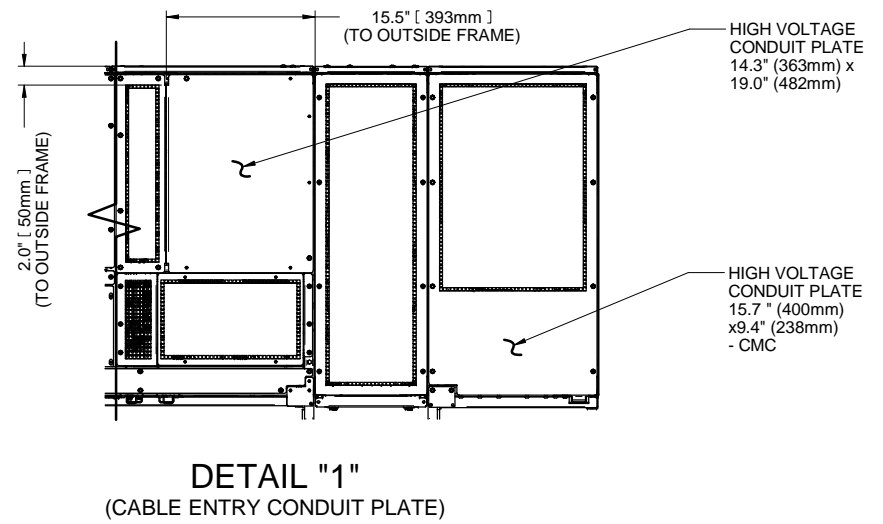
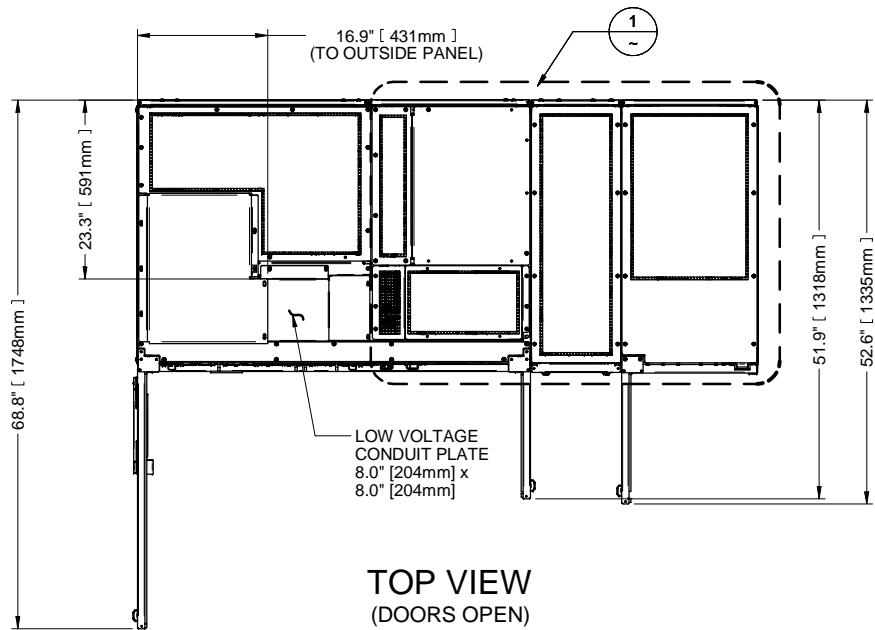

- NOTES
1. ALL DIMENSIONS ARE IN inches [mm].
  2. UNIT BOTTOM IS STRUCTURALLY ADEQUATE FOR FORKLIFT HANDLING.

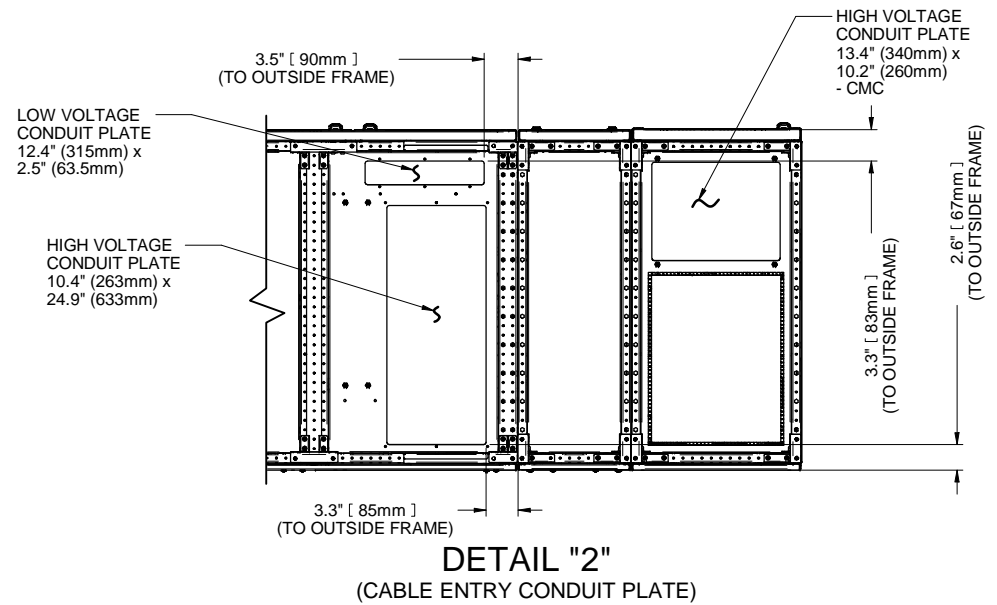
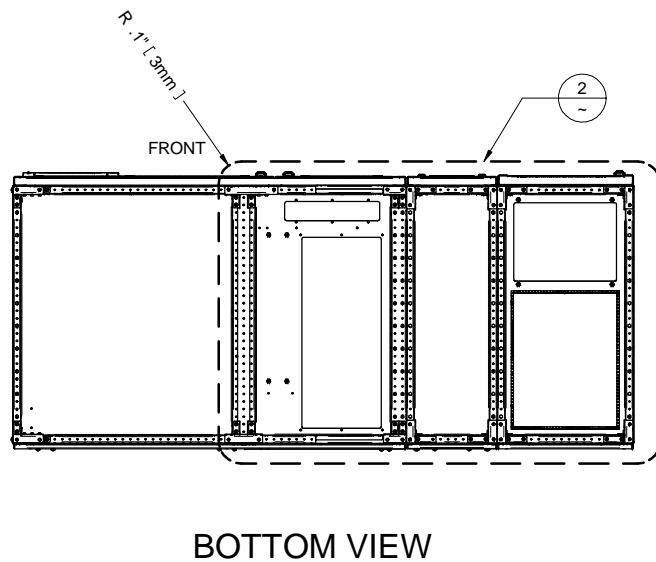

SHEET NO. 4 OF 6	DRAWN BY: JASON ZHANG	TITLE
ECN NO.	DESIGNED BY: JASON ZHANG	UPS CONDUIT PLATE DETAILS SMS AND 1+N MULTI-MODULE, 250kVA-400kVA UPS, 480V, WITH SHARING INDUCTOR AND COMMON MODE CHOKE LIEBERT EXL S1
ECN NO.	JASON ZHANG	
REF DWG.	APPROVED BY: S. MAJOR	
REF DWG.	S. MAJOR	

UPS CONDUIT PLATE DETAILS  
SMS AND 1+N MULTI-MODULE, 250kVA-400kVA UPS, 480V,  
WITH SHARING INDUCTOR AND COMMON MODE CHOKE  
LIEBERT EXL S1

DWG. NO. ES1-05-S035	DATE (LATEST REV.) 1/29/2019
REVISION 0	1050 DEARBORN DR P.O. BOX 29186 COLUMBUS, OH 43229



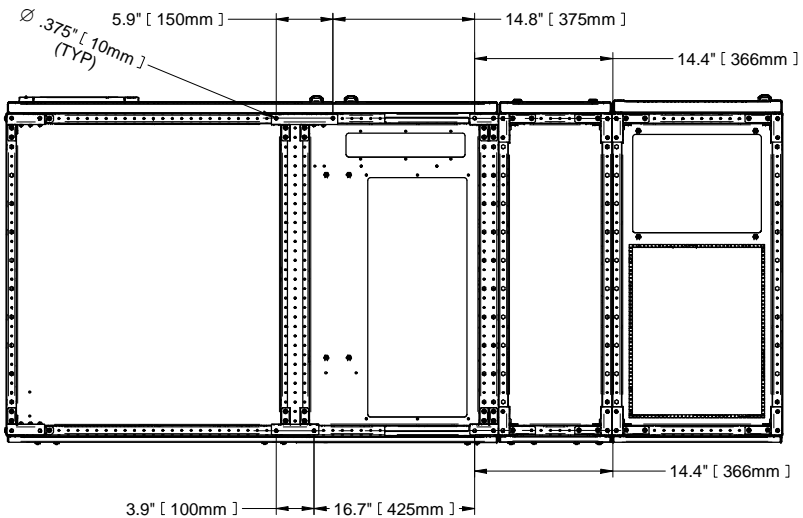

**BOTTOM VIEW**  
(BOLT HOLE LAYOUT)

**NOTES**

1. ALL DIMENSIONS ARE IN inches [mm].
2. UNIT BOTTOM IS STRUCTURALLY ADEQUATE FOR FORKLIFT HANDLING.

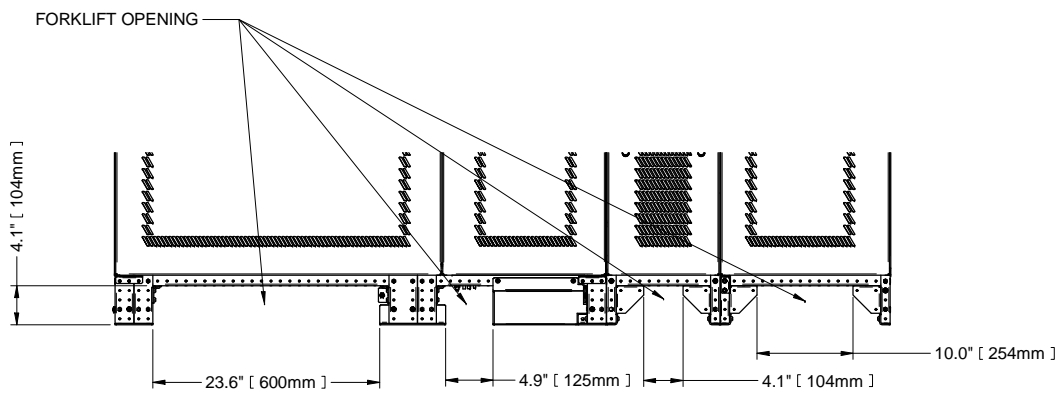

**FRONT VIEW**

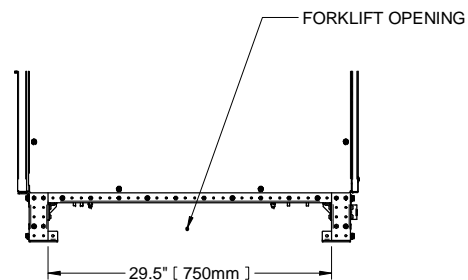

**RIGHT SIDE VIEW**

SHEET NO. 5 OF 6	DRAWN BY: JASON ZHANG	TITLE  <b>UPS BASE DRAWING</b> <b>SMS AND 1+N MULTI-MODULE, 250kVA-400kVA UPS, 480V,</b> <b>WITH SHARING INDUCTOR AND COMMON MODE CHOKE</b> <b>LIEBERT EXL S1</b>
ECN NO.	DESIGNED BY: JASON ZHANG	
REF DWG.	APPROVED BY:	
REF DWG	S. MAJOR	

DWG. NO. ES1-05-S035	1050 DEARBORN DR P.O. BOX 29186 COLUMBUS, OH 43229
DATE (LATEST REV.) 1/29/2019	
REVISION 0	



NOTES

1. ALL DIMENSIONS ARE IN inches [mm].

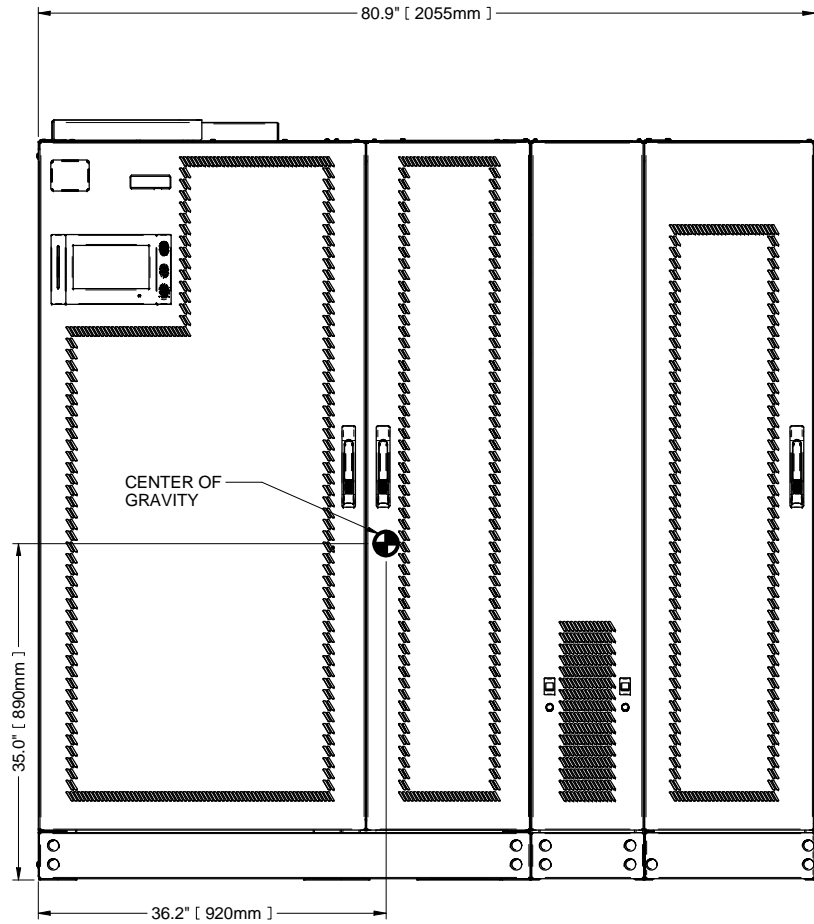

FRONT VIEW

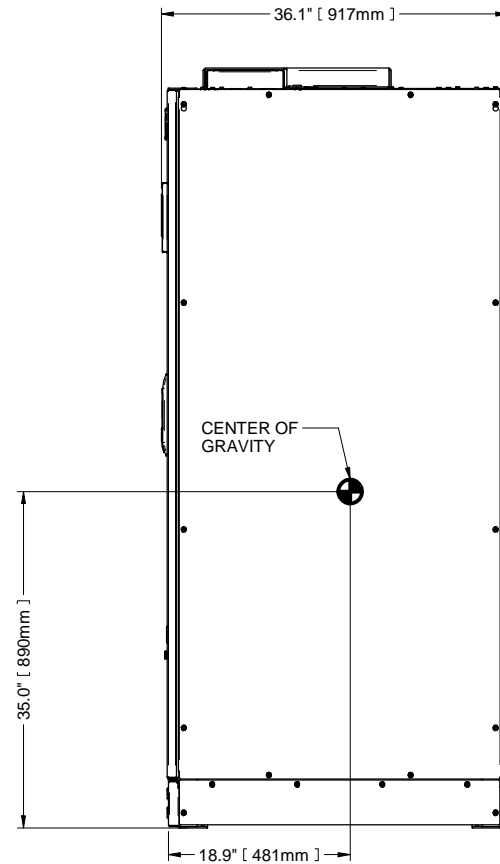

RIGHT SIDE VIEW

SHEET NO. 6 OF 6	DRAWN BY: JASON ZHANG	TITLE  UPS SHIPPING SMS AND 1+N MULTI-MODULE, 250kVA-400kVA UPS, 480V, WITH SHARING INDUCTOR AND COMMON MODE CHOKE LIEBERT EXL S1
ECN NO	DESIGNED BY: JASON ZHANG	
REF DWG.	APPROVED BY:	
REF DWG	S. MAJOR	

DWG. NO. ES1-05-S035	1050 DEARBORN DR P.O. BOX 29186 COLUMBUS, OH 43229
DATE (LATEST REV.) 1/29/2019	
REVISION 0	



NOTES

1. ALL DIMENSIONS ARE IN inches [mm].
2. 24" [610mm] MINIMUM CLEARANCE ABOVE UNIT REQUIRED FOR AIR EXHAUST. 36" [914mm] FRONT ACCESS IS REQUIRED FOR SERVICE.
3. KEEP CABINET WITHIN 15 DEGREES OF VERTICAL.
4. ALL WIRING MUST BE IN ACCORDANCE WITH NATIONAL AND LOCAL ELECTRICAL CODES.
5. UNIT BOTTOM IS STRUCTURALLY ADEQUATE FOR FORKLIFT HANDLING.
6. WIDTH DIMENSIONS INCLUDE SIDE PANELS.

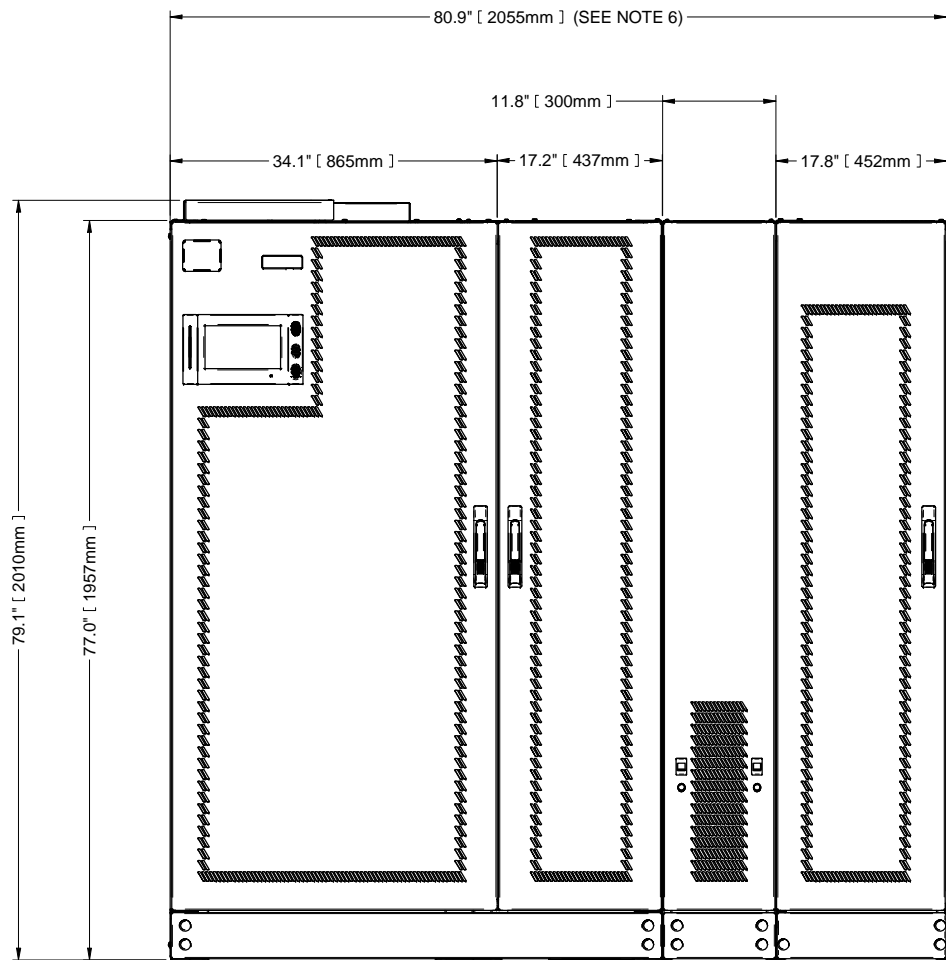

FRONT VIEW

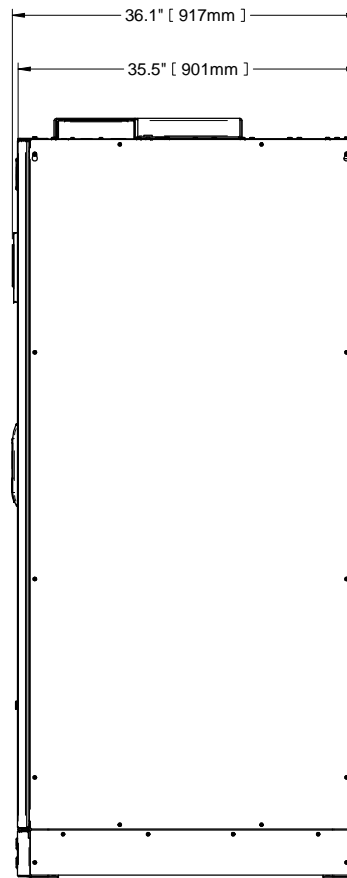

RIGHT SIDE VIEW

SHEET NO. 1 OF 6	DRAWN BY: JASON ZHANG	TITLE  OUTLINE DRAWING SMS AND 1+N MULTI-MODULE, 250kVA-400kVA UPS, 480V, WITH BFD, SHARING INDUCTOR AND COMMON MODE CHOKE LIEBERT EXL S1
ECN NO.	DESIGNED BY: JASON ZHANG	
REF DWG.	APPROVED BY:	
REF DWG	S. MAJOR	

OUTLINE DRAWING  
SMS AND 1+N MULTI-MODULE, 250kVA-400kVA UPS, 480V,  
WITH BFD, SHARING INDUCTOR AND COMMON MODE CHOKE  
LIEBERT EXL S1

DWG. NO. ES1-05-S036	1050 DEARBORN DR P.O. BOX 29186 COLUMBUS, OH 43229
DATE (LATEST REV.) 1/29/2019	
REVISION 0	



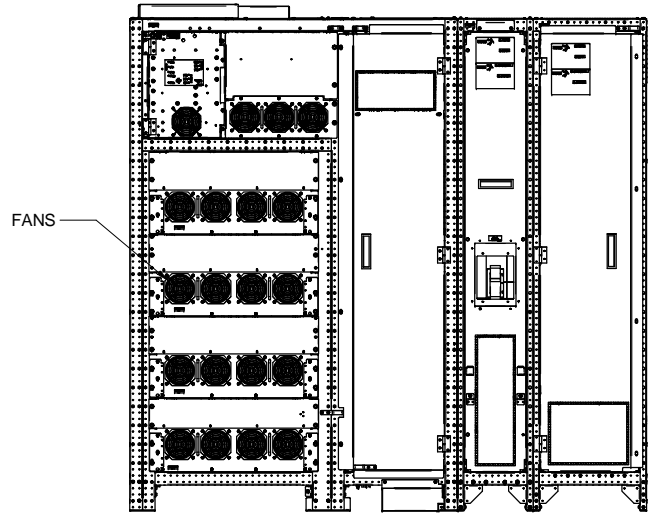

FANS

**FRONT VIEW**  
(DOORS REMOVED)

BOX MTG COVER  
LOW VOLTAGE TOP

LOW VOLTAGE  
CONDUIT BOX

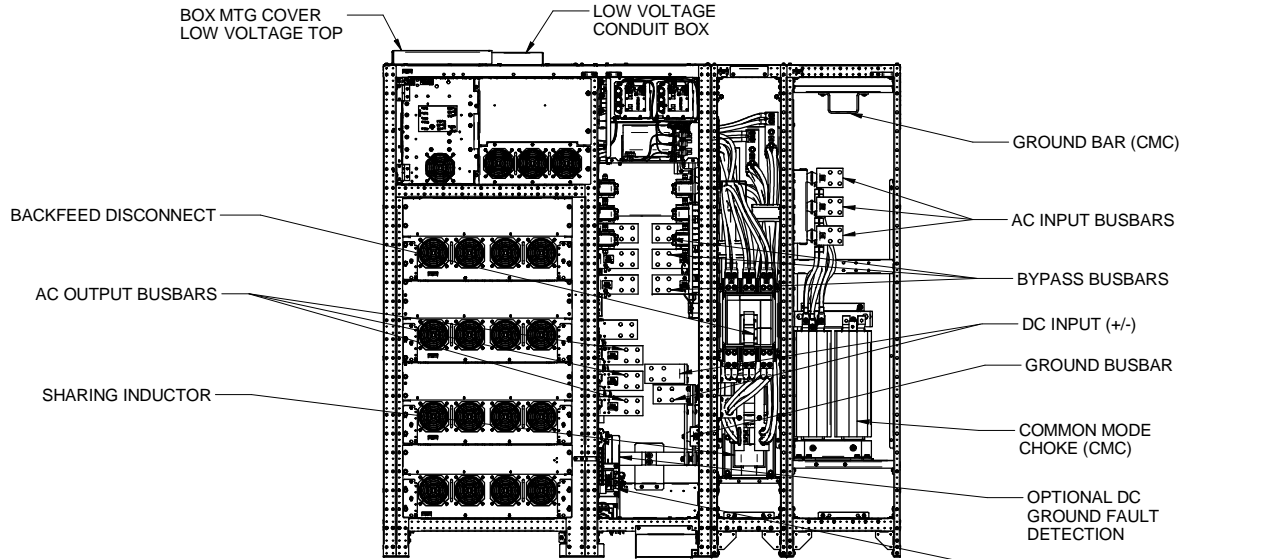

BACKFEED DISCONNECT

AC OUTPUT BUSBARS

SHARING INDUCTOR

GROUND BAR (CMC)

AC INPUT BUSBARS

BYPASS BUSBARS

DC INPUT (+/-)

GROUND BUSBAR

COMMON MODE  
CHOKE (CMC)

OPTIONAL DC  
GROUND FAULT  
DETECTION

OPTIONAL 120VAC RBB  
SHUNT TRIP POWER SUPPLY,  
TOP CABLE ENTRY

**FRONT VIEW**  
(DOORS AND PANELS REMOVED)

SHEET NO. 2 OF 6	DRAWN BY: JASON ZHANG	TITLE
ECN NO.	DESIGNED BY: JASON ZHANG	<p align="center"><b>MAIN COMPONENTS DRAWING</b></p> <p align="center">SMS AND 1+N MULTI-MODULE, 250kVA-400kVA UPS, 480V, WITH BFD, SHARING INDUCTOR AND COMMON MODE CHOKE</p> <p align="center">LIEBERT EXL S1</p>
ECN NO	APPROVED BY: S. MAJOR	
REF DWG.		
REF DWG		

**MAIN COMPONENTS DRAWING**

SMS AND 1+N MULTI-MODULE, 250kVA-400kVA UPS, 480V,  
WITH BFD, SHARING INDUCTOR AND COMMON MODE CHOKE

LIEBERT EXL S1

DWG. NO. ES1-05-S036	
DATE (LATEST REV.) 1/29/2019	
REVISION 0	1050 DEARBORN DR P.O. BOX 29186 COLUMBUS, OH 43229

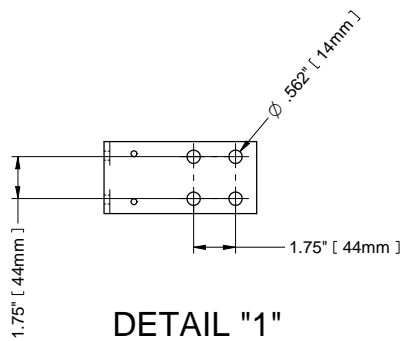

**DETAIL "1"**  
(BYPASS BUSBAR)

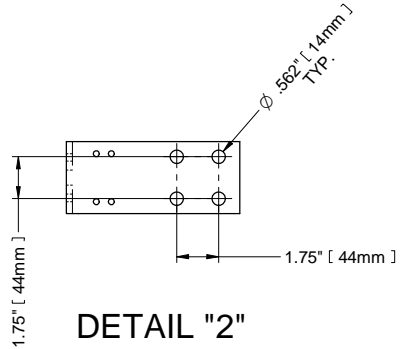

**DETAIL "2"**  
(OUTPUT BUSBAR)

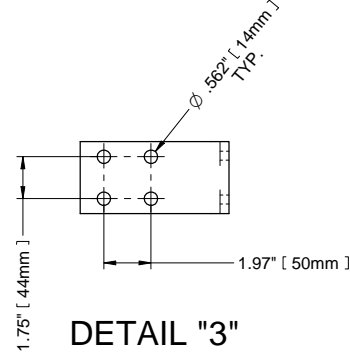

**DETAIL "3"**  
(DC BUSBAR +/-)

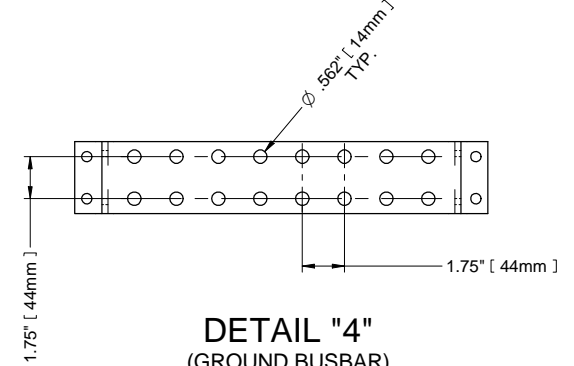

**DETAIL "4"**  
(GROUND BUSBAR)

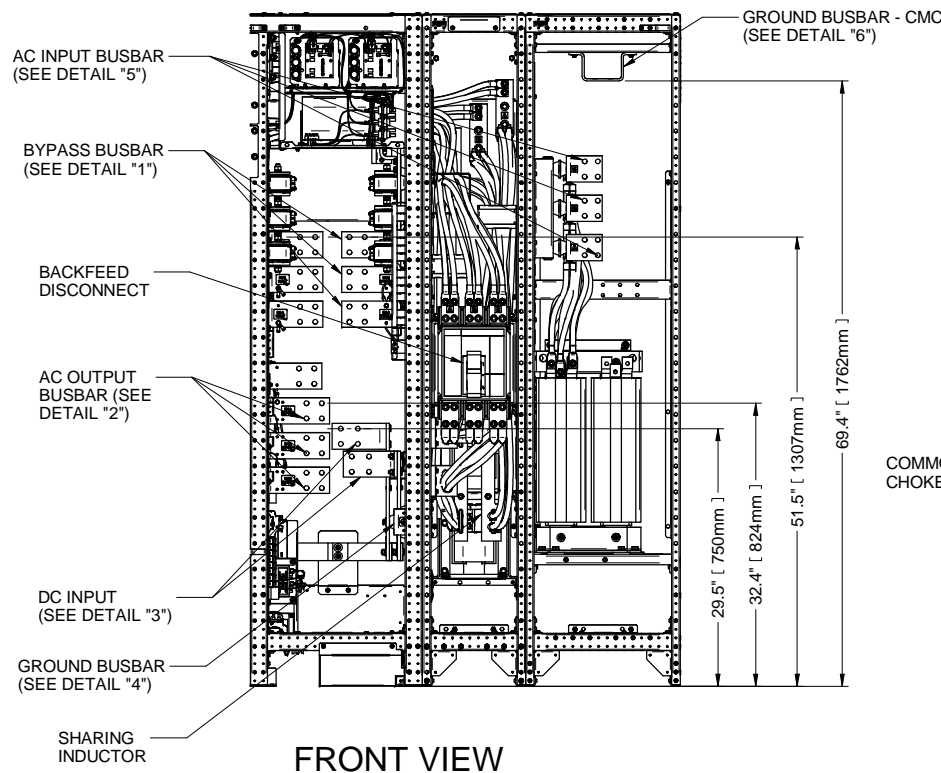

**FRONT VIEW**

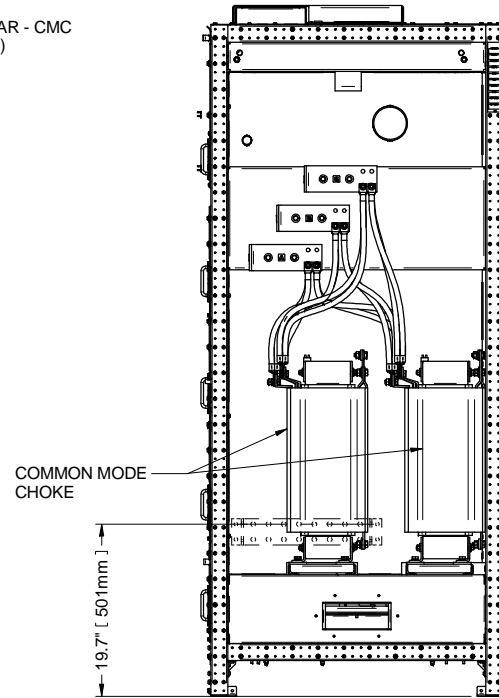

**RIGHT SIDE VIEW**

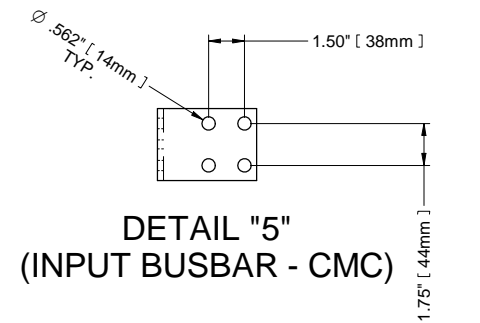

**DETAIL "5"**  
(INPUT BUSBAR - CMC)

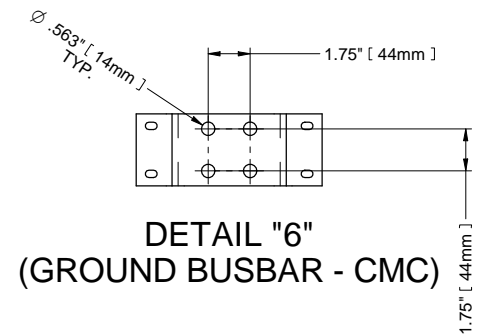

**DETAIL "6"**  
(GROUND BUSBAR - CMC)

**NOTES**

1. ALL DIMENSIONS ARE IN inches [mm].
2. CONTROL AND POWER WIRING MUST BE RUN IN SEPARATE CONDUITS.
3. ALL WIRING MUST BE IN ACCORDANCE WITH NATIONAL AND LOCAL ELECTRICAL CODES.
4. COPPER AND ALUMINUM CABLES ARE ACCEPTABLE

SHEET NO. 3 OF 6	DRAWN BY: JASON ZHANG	TITLE
ECN NO.	DESIGNED BY: JASON ZHANG	<b>UPS ELECTRICAL CONNECTION</b> <b>SMS AND 1+N MULTI-MODULE, 250kVA-400kVA UPS, 480V,</b> <b>WITH BFD, SHARING INDUCTOR AND COMMON MODE CHOKE</b> <b>LIEBERT EXL S1</b>
REF DWG.	APPROVED BY: S. MAJOR	
REF DWG		

**UPS ELECTRICAL CONNECTION**  
**SMS AND 1+N MULTI-MODULE, 250kVA-400kVA UPS, 480V,**  
**WITH BFD, SHARING INDUCTOR AND COMMON MODE CHOKE**  
**LIEBERT EXL S1**

DWG. NO. ES1-05-S036
DATE (LATEST REV.) 1/29/2019
REVISION 0
1050 DEARBORN DR P.O. BOX 29186 COLUMBUS, OH 43229





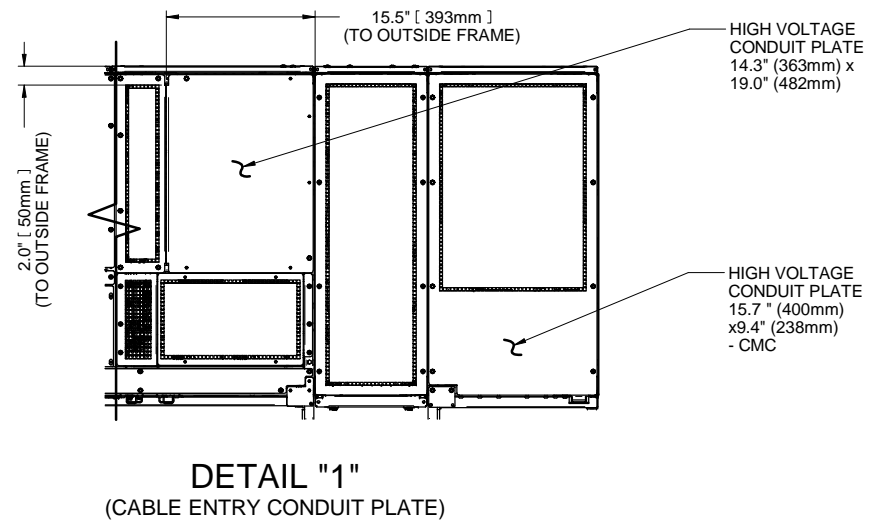
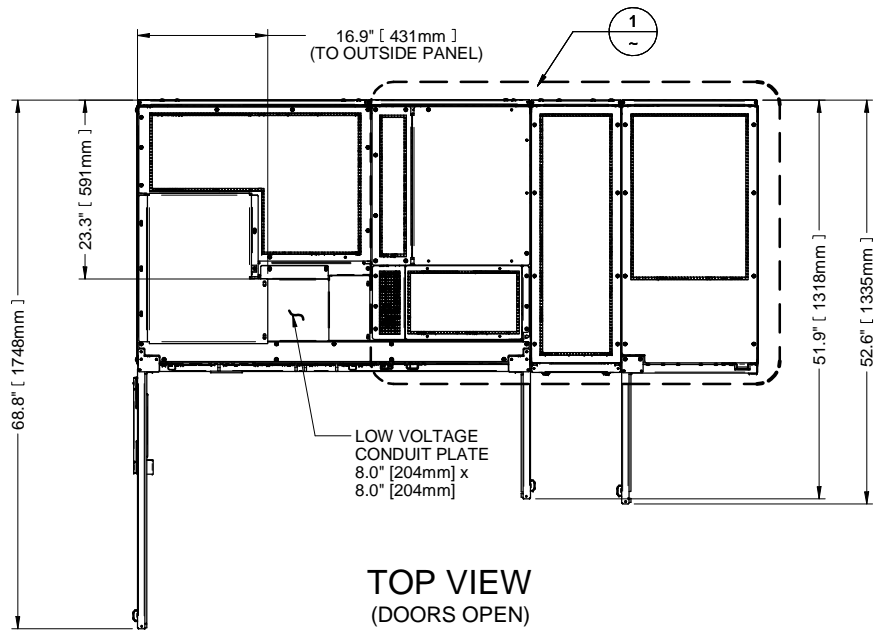

- NOTES
1. ALL DIMENSIONS ARE IN inches [mm].
  2. UNIT BOTTOM IS STRUCTURALLY ADEQUATE FOR FORKLIFT HANDLING.

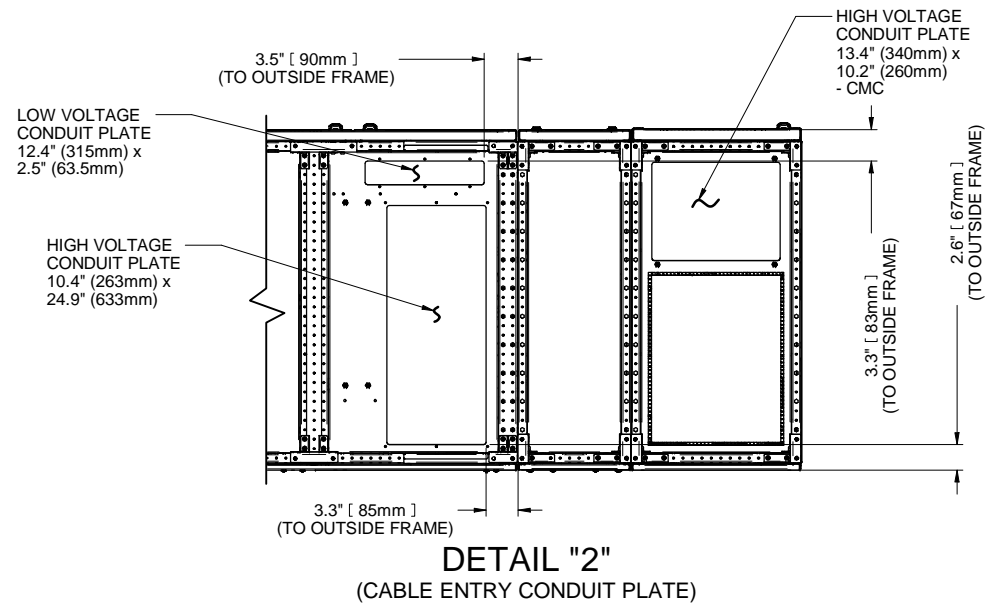
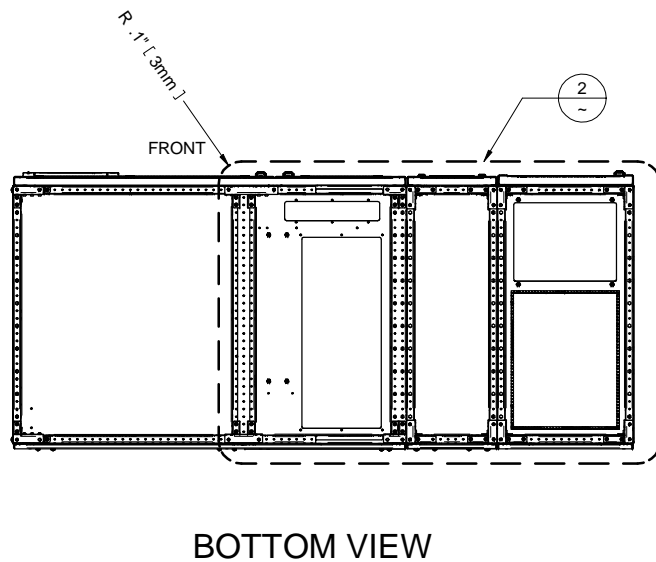

SHEET NO. 4 OF 6	DRAWN BY: JASON ZHANG	TITLE
ECN NO.	DESIGNED BY: JASON ZHANG	UPS CONDUIT PLATE DETAILS SMS AND 1+N MULTI-MODULE, 250kVA-400kVA UPS, 480V, WITH BFD, SHARING INDUCTOR AND COMMON MODE CHOKE LIEBERT EXL S1
ECN NO.	JASON ZHANG	
REF DWG.	APPROVED BY: S. MAJOR	
REF DWG.	S. MAJOR	

UPS CONDUIT PLATE DETAILS  
SMS AND 1+N MULTI-MODULE, 250kVA-400kVA UPS, 480V,  
WITH BFD, SHARING INDUCTOR AND COMMON MODE CHOKE  
LIEBERT EXL S1

DWG. NO. ES1-05-S036	DATE (LATEST REV.) 1/29/2019
REVISION 0	1050 DEARBORN DR P.O. BOX 29186 COLUMBUS, OH 43229



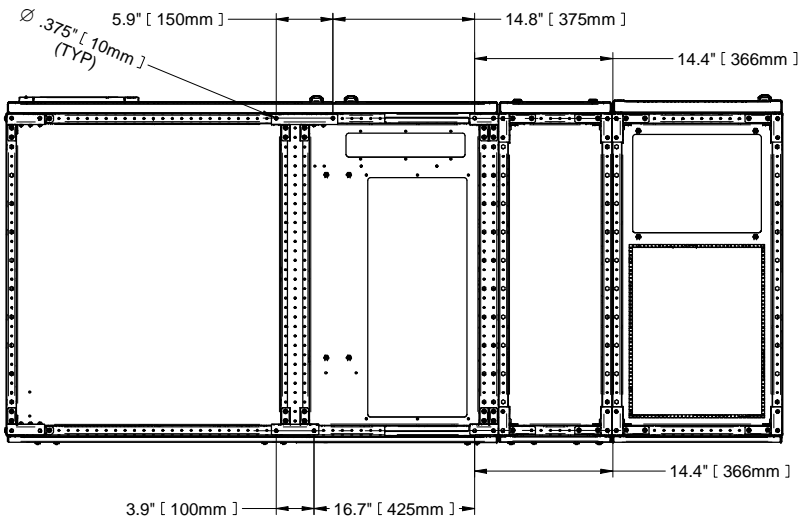

**BOTTOM VIEW**  
(BOLT HOLE LAYOUT)

**NOTES**

1. ALL DIMENSIONS ARE IN inches [mm].
2. UNIT BOTTOM IS STRUCTURALLY ADEQUATE FOR FORKLIFT HANDLING.

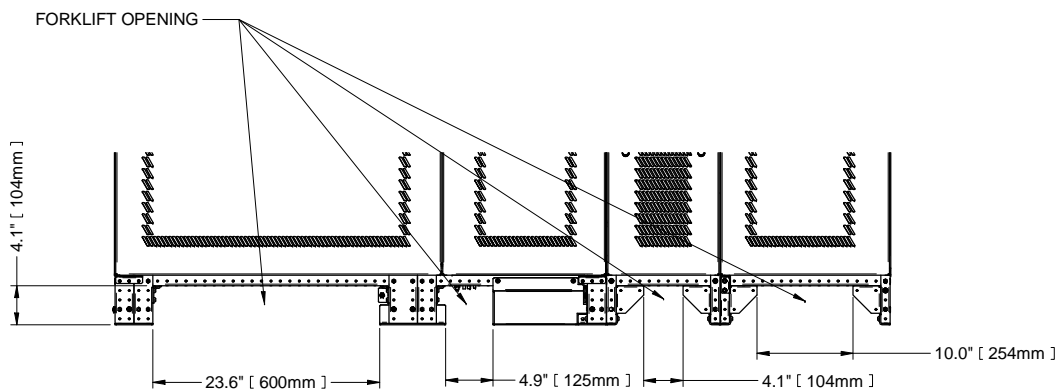

**FRONT VIEW**

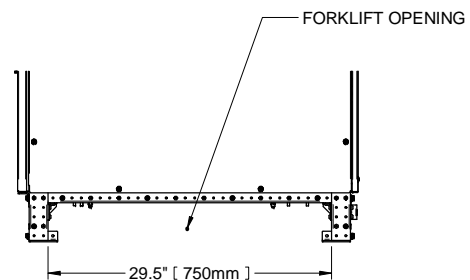

**RIGHT SIDE VIEW**

SHEET NO. 5 OF 6	DRAWN BY: JASON ZHANG	TITLE  <b>UPS BASE DRAWING</b> <b>SMS AND 1+N MULTI-MODULE, 250kVA-400kVA UPS, 480V,</b> <b>WITH BFD, SHARING INDUCTOR AND COMMON MODE CHOKE</b> <b>LIEBERT EXL S1</b>
ECN NO.	DESIGNED BY: JASON ZHANG	
ECN NO	APPROVED BY: S. MAJOR	
REF DWG. REF DWG		

DWG. NO. ES1-05-S036	
DATE (LATEST REV.) 1/29/2019	
REVISION 0	1050 DEARBORN DR P.O. BOX 29186 COLUMBUS, OH 43229

NOTES

1. ALL DIMENSIONS ARE IN inches [mm].

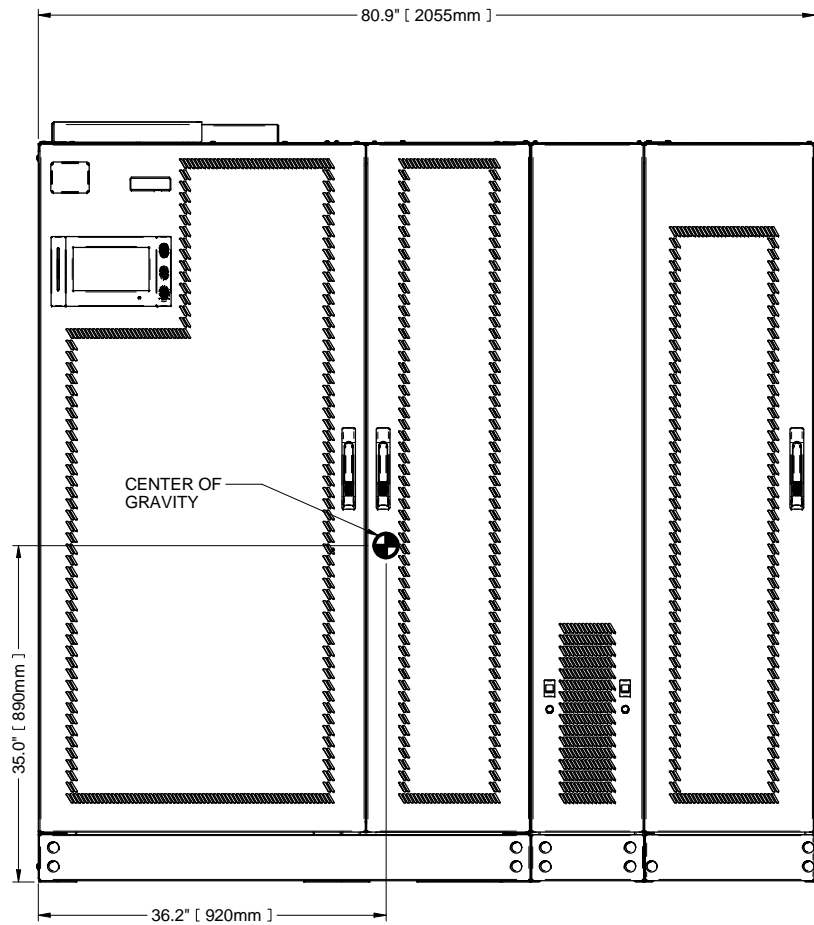

FRONT VIEW

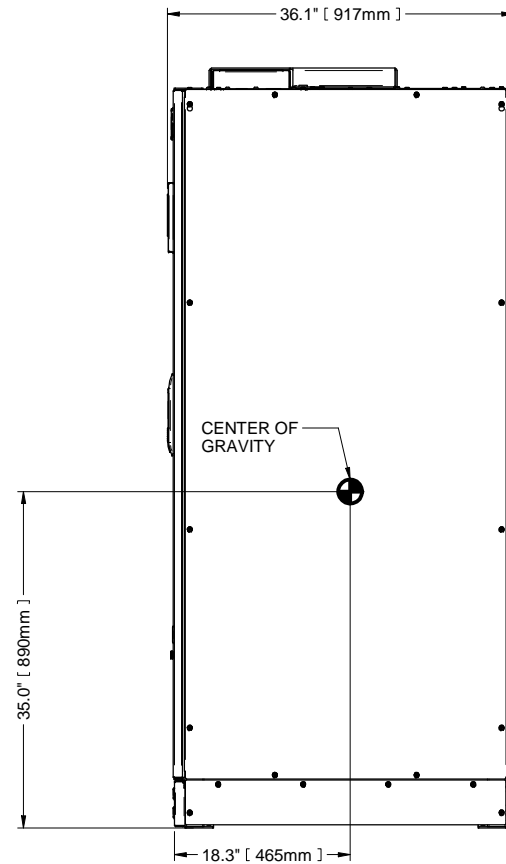

RIGHT SIDE VIEW

SHEET NO. 6 OF 6	DRAWN BY: JASON ZHANG	TITLE  UPS SHIPPING SMS AND 1+N MULTI-MODULE, 250kVA-400kVA UPS, 480V, WITH BFD, SHARING INDUCTOR AND COMMON MODE CHOKE LIEBERT EXL S1
ECN NO	DESIGNED BY: JASON ZHANG	
REF DWG.	APPROVED BY:	
REF DWG	S. MAJOR	

DWG. NO. ES1-05-S036	1050 DEARBORN DR P.O. BOX 29186 COLUMBUS, OH 43229
DATE (LATEST REV.) 1/29/2019	
REVISION 0	



This page intentionally left blank

### **Connect with Vertiv on Social Media**



<https://www.facebook.com/vertiv/>



<https://www.instagram.com/vertiv/>



<https://www.linkedin.com/company/vertiv/>



<https://www.twitter.com/Vertiv/>



---

Vertiv.com | Vertiv Headquarters, 1050 Dearborn Drive, Columbus, OH, 43085, USA

© 2021 Vertiv Group Corp. All rights reserved. Vertiv™ and the Vertiv logo are trademarks or registered trademarks of Vertiv Group Corp. All other names and logos referred to are trade names, trademarks or registered trademarks of their respective owners. While every precaution has been taken to ensure accuracy and completeness here, Vertiv Group Corp. assumes no responsibility, and disclaims all liability, for damages resulting from use of this information or for any errors or omissions. Specifications, rebates and other promotional offers are subject to change at Vertiv's sole discretion upon notice.

SL-26091\_REV8\_08-21