

SITE PLANNING DATA—LIEBERT EXM™ 3-PHASE UPS: 10-100kVA/kW, 60Hz, 208-480VAC, SINGLE INPUT

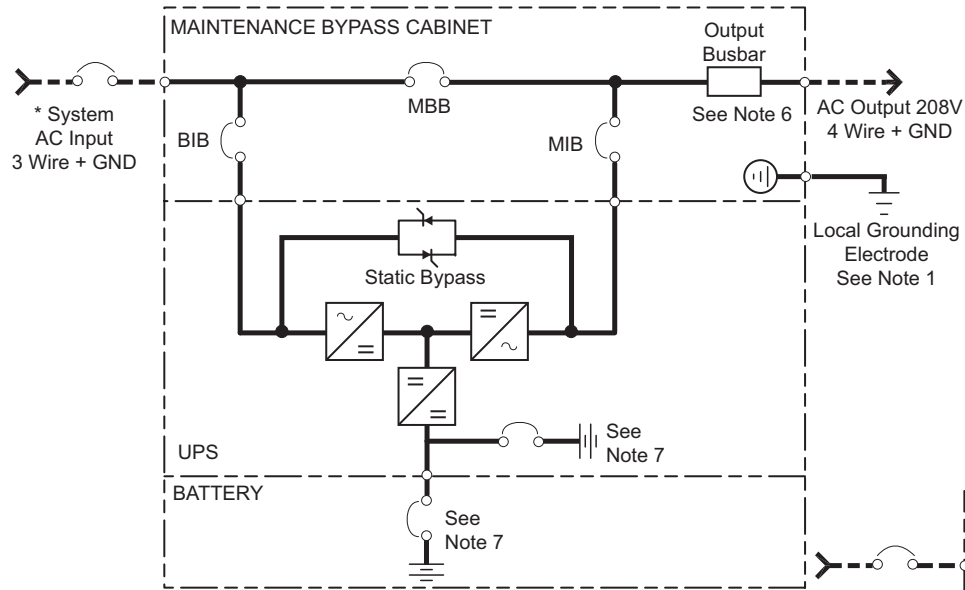

- BIB - Bypass Isolation Breaker
- MBB - Maintenance Bypass Breaker
- MIB - Maintenance Isolation Breaker
- - - - Field-Supplied Wiring

* External Overcurrent Protection By Others
Refer to Notes for Tables on page 12.

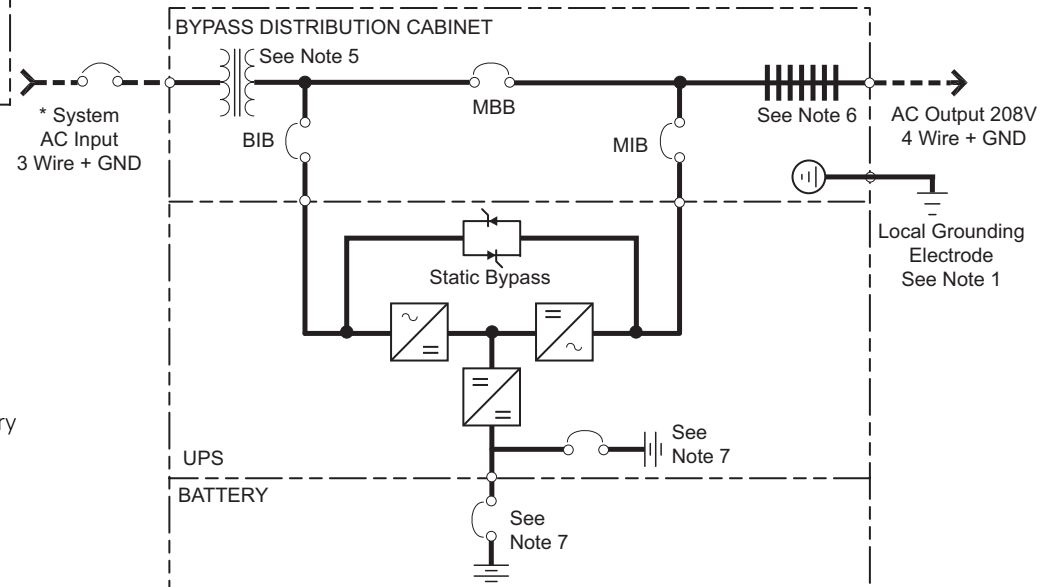

1. Install in accordance with national and local electrical codes.
2. Input and bypass must share the same single source.
3. UPS system input and output cables must be run in separate conduits.
4. Control wiring must be run in separate conduits
5. Optional input transformer.
6. Optional distribution for 10-100kVA units only.
7. Internal battery breaker is optional on UPS with internal batteries; battery breaker is factory-supplied with external Liebert battery cabinets.



Site Planning Data—Liebert® EXM™ 3-Phase UPS: 10-100kVA/kW, 60Hz, 208-480VAC, Single Input

Table 1 Site planning data—10-100kVA, 60Hz, 208VAC, single input

UPS Rating		Voltage		AC Input			Battery		AC Output		Mechanical Data				
kVA	kW	Input	Output	Current, A		Rec. OPD	Nom. VDC	Maximum Discharge	Nom.	OPD	Dimensions WxDxH, in. (mm)	Unit Weight, lb. (kg)		UPS Heat Dissipation BTU/hr (kW)	Cooling Air CFM (m³/hr)
				Nom.	Max							40 kVA Frame	100 kVA Frame		
10	10	208	208	30	34	45	288	47	28	40	23-5/8x39-3/8x78-3/4 (600x1000x2000)	684 (310)	N/A	2217 (0.7)	67.8 (115)
15	15	208	208	45	51	70	288	70	42	60		684 (310)	N/A	3245 (1.0)	67.8 (115)
20	20	208	208	59	68	90	288	93	56	70		684 (310)	684 (310)	3843 (1.1)	67.8 (115)
30	30	208	208	89	102	150	288	140	83	110		758 (344)	N/A	6189 (1.8)	135.6 (231)
40	40	208	208	119	136	175	288	187	111	150		758 (344)	758 (344)	7610 (2.2)	135.6 (231)
60	60	208	208	178	205	300	288	280	167	225		N/A	844 (383)	11,278 (3.3)	203.4 (346)
80	80	208	208	237	273	350	288	373	222	300		N/A	918 (416)	14,977 (4.4)	271.2 (462)
100	100	208	208	297	341	450	288	467	278	350		N/A	992 (450)	18,645 (5.5)	339 (575)

Table 2 Site planning data—10-100kVA, 60Hz, 480VAC in, 208VAC out, single input, with 480V:208V transformer

UPS Rating		Voltage		AC Input			Battery		AC Output Current, A		Mechanical Data						
kVA	kW	Input	Output	Current, A		Rec. OPD	Nom. VDC	Maximum Discharge	Nom.	Rec. OPD	Dimensions WxDxH, in. (mm)	Unit Weight, lb. (kg)		* UPS Heat Dissipation BTU/hr (kW)	Transformer Heat Dissipation BTU/hr (kW)	Total Heat Dissipation BTU/hr (kW)	Cooling Air CFM (m³/hr)
				Nom.	Max							40kVA Frame	100kVA Frame				
10	10	480	208	13	15	20	288	47	28	40	23-5/8x39-3/8x78-3/4 (600x1000x2000)	684 (310)	NA	2217 (0.7)	1638 (0.5)	3855 (1.2)	67.8 (115)
15	15	480	208	20	23	30	288	70	42	60		684 (310)	NA	3245 (1.0)	2013 (0.6)	5258 (1.6)	67.8 (115)
20	20	480	208	27	31	40	288	93	56	70		684 (310)	684 (310)	3843 (1.1)	2733 (0.8)	6576 (1.9)	67.8 (115)
30	30	480	208	40	46	60	288	140	83	110		758 (344)	NA	6189 (1.8)	4948 (1.5)	11,137 (3.3)	135.6 (231)
40	40	480	208	53	61	80	288	187	111	150		758 (344)	758 (344)	7610 (2.2)	5343 (1.6)	12,953 (3.8)	135.6 (231)
60	60	480	208	80	91	125	288	280	167	225		NA	844 (383)	11,278 (3.3)	6855 (2.0)	18,133 (5.3)	203.4 (346)
80	80	480	208	106	122	175	288	373	222	300		NA	918 (416)	14,977 (4.4)	9513 (2.8)	24,490 (7.2)	271.2 (462)
100	100	480	208	133	152	200	288	467	278	350		NA	992 (450)	18,645 (5.5)	10,608 (3.1)	29,253 (8.6)	339 (575)

* Heat dissipation includes values for the Bypass Distribution Cabinet.

SITE PLANNING DATA—LIEBERT® EXM™ 3-PHASE UPS: 10-100kVA/kW, 60Hz, 208-480VAC, DUAL INPUT

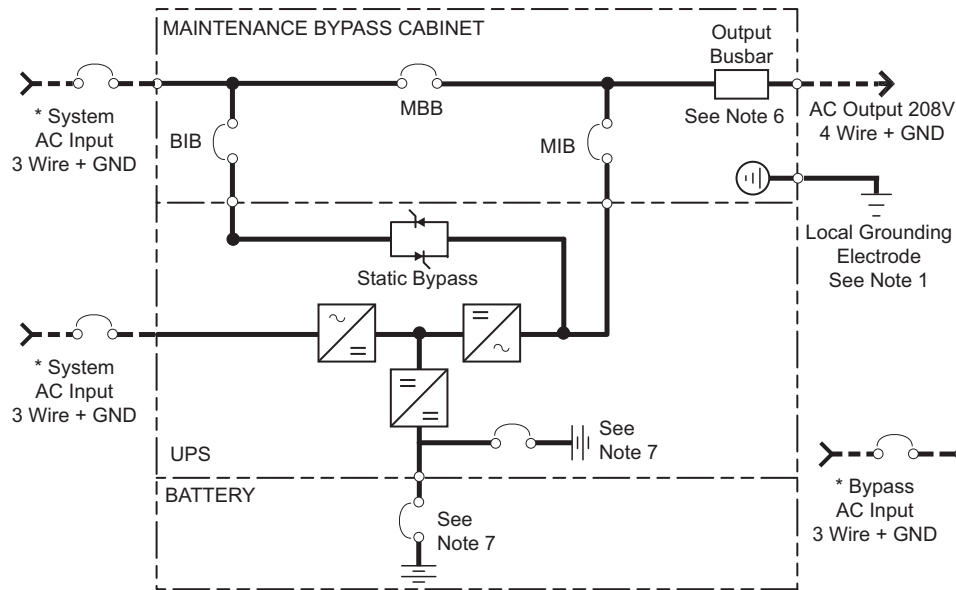

- BIB - Bypass Isolation Breaker
- MBB - Maintenance Bypass Breaker
- MIB - Maintenance Isolation Breaker
- RIB - Rectifier Input Breaker
- - - - - Field-Supplied Wiring

* External Overcurrent Protection By Others
Refer to Notes for Tables on page 12.

1. Install in accordance with national and local electrical codes.
2. Input and bypass must share the same single source.
3. UPS system input and output cables must be run in separate conduits.
4. Control wiring must be run in separate conduits
5. Optional input transformer.
6. Optional distribution for 10-100kVA units only.
7. Internal battery breaker is optional on UPS with internal batteries; battery breaker is factory-supplied with external Liebert battery cabinets.

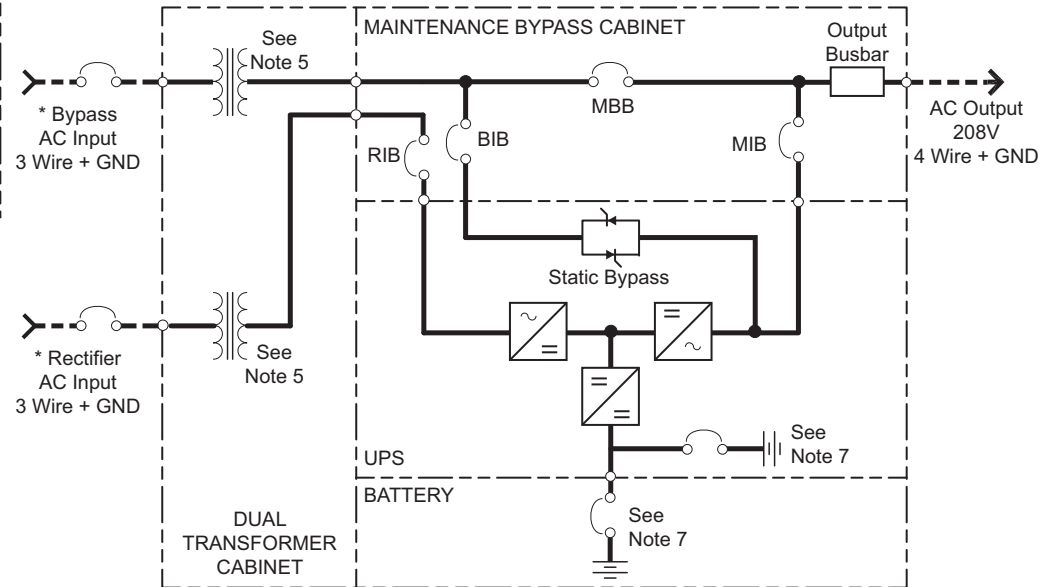

Table 3 Site planning data—10-100kVA, 60Hz, 208VAC, dual input

UPS Rating		Voltage		AC Input			Bypass Current, A		Battery		AC Output		Mechanical Data					
kVA	kW	Input	Output	Rectifier Current, A		Rec. OPD	Nom.	Rec. OPD	Nom. VDC	Maximum Discharge	Nom.	OPD	Dimensions WxDxH, in. (mm)	Unit Weight, lb. (kg)		UPS Heat Dissipation, BTU/hr (kW)	Cooling Air, CFM (m ³ /hr)	
				Nom.	Max									40 kVA Frame	100 kVA Frame			
10	10	208	208	30	34	45	28	40	288	47	28	40		23-5/8x39-3/8x78-3/4 (600x1000x2000)	684 (310)	NA	2217 (0.7)	67.8 (115)
15	15	208	208	45	51	70	42	60	288	70	42	60			684 (310)	NA	3245 (1.0)	67.8 (115)
20	20	208	208	59	68	90	56	70	288	93	56	70	684 (310)		684 (310)	3843 (1.1)	67.8 (115)	
30	30	208	208	89	102	150	83	110	288	140	83	110	758 (344)		NA	6189 (1.8)	135.6 (231)	
40	40	208	208	119	136	175	111	150	288	187	111	150	758 (344)		758 (344)	7610 (2.2)	135.6 (231)	
60	60	208	208	178	205	300	167	225	288	280	167	225	NA		844 (383)	11,278 (3.3)	203.4 (346)	
80	80	208	208	237	273	350	222	300	288	373	222	300	NA		918 (416)	14,977 (4.4)	271.2 (462)	
100	100	208	208	297	341	450	278	350	288	467	278	350	NA		992 (450)	18,645 (5.5)	339 (575)	

Table 4 Site planning data—10-100kVA, 60Hz, 480VACin, 208VAC out, dual input, with 480V:208V transformer

UPS Rating		Voltage		AC Input			Bypass Current, A		Battery		AC Output Current, A		Mechanical Data						
kVA	kW	Input	Output	Rectifier Current, A		Rec. OPD	Nom.	Rec. OPD	Nom. VDC	Maximum Discharge	Nom.	Rec. OPD	Dimensions WxDxH, in. (mm)	Unit Weight, lb. (kg)		* UPS Heat Dissipation BTU/hr (kW)	Transformer Heat Dissipation, BTU/hr (kW)	Total Heat Dissipation BTU/hr (kW)	Cooling Air, CFM (m ³ /hr)
				Nom.	Max									40kVA Frame	100kVA Frame				
10	10	480	208	13	15	20	28	40	288	47	28	40	23-5/8x39-3/8x78-3/4 (600x1000x2000)	684 (310)	NA	2217 (0.7)	1638 (0.5)	3855 (1.2)	67.8 (115)
15	15	480	208	20	23	30	42	60	288	70	42	60		684 (310)	NA	3245 (1.0)	2013 (0.6)	5258 (1.6)	67.8 (115)
20	20	480	208	27	31	40	56	70	288	93	56	70		684 (310)	684 (310)	3843 (1.1)	2733 (0.8)	6576 (1.9)	67.8 (115)
30	30	480	208	40	46	60	83	110	288	140	83	110		758 (344)	NA	6189 (1.8)	4948 (1.5)	11,137 (3.3)	135.6 (231)
40	40	480	208	53	61	80	111	150	288	187	111	150		758 (344)	758 (344)	7610 (2.2)	5343 (1.6)	12,953 (3.8)	135.6 (231)
60	60	480	208	80	91	125	167	225	288	280	167	225		NA	844 (383)	11,278 (3.3)	6855 (2.0)	18,133 (5.3)	203.4 (346)
80	80	480	208	106	122	175	222	300	288	373	222	300		NA	918 (416)	14,977 (4.4)	9513 (2.8)	24,490 (7.2)	271.2 (462)
100	100	480	208	133	152	200	278	350	288	467	278	350		NA	992 (450)	18,645 (5.5)	10,608 (3.1)	29,253 (8.6)	339 (575)

* Heat dissipation includes values for the Transformer Cabinet.

SITE PLANNING DATA—LIEBERT® EXM™ 3-PHASE UPS: 20-200kVA, 60Hz, 208VAC, 200kVA FRAME, SINGLE INPUT

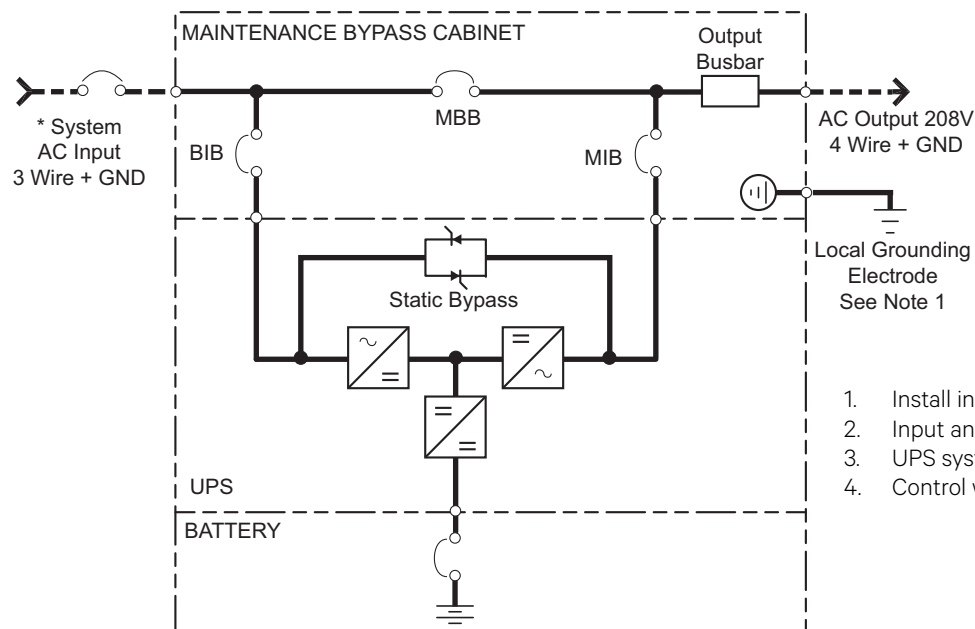

- BIB - Bypass Isolation Breaker
- MBB - Maintenance Bypass Breaker
- MIB - Maintenance Isolation Breaker
- - - - Field-Supplied Wiring

* External Overcurrent Protection By Others
Refer to Notes for Tables on page 12.

1. Install in accordance with national and local electrical codes.
2. Input and bypass must share the same single source.
3. UPS system input and output cables must be run in separate conduits.
4. Control wiring must be run in separate conduits

Table 5 Site planning data—20-200kVA, 60Hz, 208VAC, 200kVA frame, single input

UPS Rating		Voltage		AC Input			Battery		AC Output Current, A		Mechanical Data			
		Input	Output	Current, A		Rec.	Nominal VDC	Maximum Discharge	Nom.	OPD	200 kVA Frame Dimensions WxDxH, in. (mm)	Unit Weight lb. (kg)	UPS Heat Dissipation BTU/hr (kW)	Cooling Air CFM (m ³ /hr)
Nom.	Max			OPD										
20	20	208	208	59	68	90	288	93	56	70	34-2/3x39-3/8x78-3/4 (880x1000x2000)	852 (387)	3843 (1.1)	68 (115)
40	40	208	208	119	136	175	288	187	111	150		926 (420)	7610 (2.2)	136 (231)
60	60	208	208	178	205	300	288	280	167	225		1000 (453)	11,278 (3.3)	203 (346)
80	80	208	208	237	273	350	288	373	222	300		1073 (487)	14,977 (4.4)	271 (462)
100	100	208	208	297	341	450	288	467	278	350		1147 (520)	18,645 (5.5)	339 (575)
120	120	208	208	356	409	600	288	560	333	450		1221 (554)	21,193 (6.2)	407 (691)
140	140	208	208	415	478	600	288	653	389	500		1295 (587)	23,512 (6.9)	475 (806)
160	160	208	208	475	546	700	288	747	444	600		1368 (621)	29,529 (8.7)	542 (922)
180	180	208	208	534	614	800	288	840	500	700		1442 (654)	31,994 (9.4)	610 (1037)
200	200	208	208	594	682	1000	288	933	555	700		1516 (688)	35,548 (10.4)	678 (1152)

SITE PLANNING DATA—LIEBERT® EXM™ 3-PHASE UPS: 20-200kVA, 60Hz, 208VAC, 200kVA FRAME, DUAL INPUT

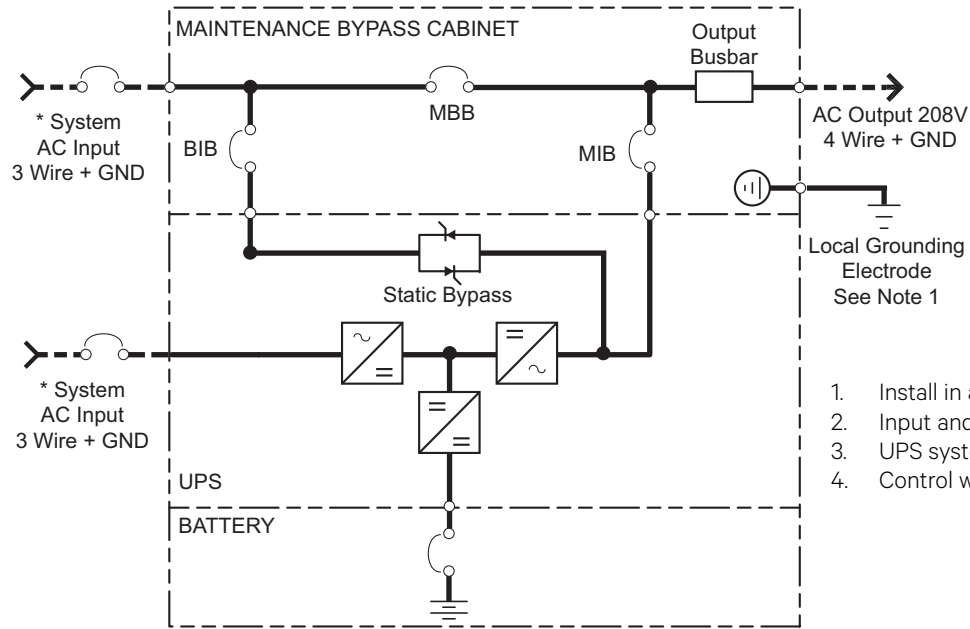

- BIB - Bypass Isolation Breaker
- MBB - Maintenance Bypass Breaker
- MIB - Maintenance Isolation Breaker
- - - - - Field-Supplied Wiring
- * External Overcurrent Protection By Others

1. Install in accordance with national and local electrical codes.
2. Input and bypass must share the same single source.
3. UPS system input and output cables must be run in separate conduits.
4. Control wiring must be run in separate conduits

Table 6 Site planning data—20-200kVA, 60Hz, 208VAC, 200kVA frame, dual input

UPS Rating		Voltage		AC Input			Bypass Current, A		Battery		AC Output Current, A		Mechanical Data			
				Current, A		Rec. OPD			Nominal VDC	Maximum Discharge			200kVA Frame Dimensions		Unit Weight lb. (kg)	UPS Heat Dissipation BTU/hr (kW)
kVA	kW	Input	Output	Nom.	Max.		Nom.	Rec.			WxDxH, in. (mm)					
20	20	208	208	59	68	90	56	70	288	93	56	70	34-2/3x39-3/8x78-3/4 (880x1000x2000)	852 (387)	3843 (1.1)	68 (115)
40	40	208	208	119	136	175	111	150	288	187	111	150		926 (420)	7610 (2.2)	136 (231)
60	60	208	208	178	205	300	167	225	288	280	167	225		1000 (453)	11,278 (3.3)	203 (346)
80	80	208	208	237	273	350	222	300	288	373	222	300		1073 (487)	14,977 (4.4)	271 (462)
100	100	208	208	297	341	450	278	350	288	467	278	350		1147 (520)	18,645 (5.5)	339 (575)
120	120	208	208	356	409	600	333	450	288	560	333	450		1221 (554)	21,193 (6.2)	407 (691)
140	140	208	208	415	478	600	389	500	288	653	389	500		1295 (587)	23,512 (6.9)	475 (806)
160	160	208	208	475	546	700	444	600	288	747	444	600		1368 (621)	29,529 (8.7)	542 (922)
180	180	208	208	534	614	800	500	700	288	840	500	700		1442 (654)	31,994 (9.4)	610 (1037)
200	200	208	208	594	682	1000	555	700	288	933	555	700		1516 (688)	35,548 (10.4)	678 (1152)

SITE PLANNING DATA—LIEBERT® EXM™ 3-PHASE UPS: 10-100kVA/kW, 60Hz, 208VAC, BATTERIES

Each Liebert EXM Battery Cabinet contains one series string of 144 cells of valve-regulated, lead-acid batteries in a matching cabinet. Multiple battery cabinets are combined into systems by attaching the cabinets together with internal wiring sized for the UPS rating. Each battery cabinet has a built in circuit breaker. Each Liebert EXM will support up to four strings of the same battery type.

Liebert Battery Cabinets are designed to attach to the left side of the UPS to provide one lineup with all the interconnecting power and control wiring provided.

Battery cabinets can also be installed detached from the UPS module. Contact application engineering for assistance in meeting site conditions.

Table 7 UPS internal batteries, 10-40kW only

Battery Manufacturer	Battery Model	Total Backup Time in Minutes					# of Internal Battery Strings	Total # of Battery Strings	Weight of UPS Plus Internal Batteries, lb (kg)
		10kW	15kW	20kW	30kW	40kW			
Enersys	HX100-FR	22	12	8	—	—	1	1	1286 (583.3)
Enersys	HX150E-FR (HX)	37	21	13	7	—	1	1	1382 (626.9)
Enersys	HX205-FR (MX)	52	32	22	13	9	1	1	1790 (811.9)
East Penn	HR1500 (GA)	27	16	11	6	—	1	1	1406 (637.7)
East Penn	HR2000 (LA)	46	27	18	10	5	1	1	1718 (779.3)

Table 8 320mm matching battery cabinet, 10-40kW only, one external battery cabinet

Battery Manufacturer	Battery Model	Total Backup Time in Minutes					# of Internal Battery Strings	# of Battery Strings	Weight of UPS Plus Internal Batteries, lb (kg)	Weight of External Battery Cabinet, lb (kg)	External Battery Cabinet Dimensions WxDxH, in, (mm)
		10kW	15kW	20kW	30kW	40kW					
Enersys	HX150E-FR (HX)	90	53	37	21	14	1	2	1382 (626.9)	977 (443.2)	12.6x39.4x78.4 (320x1000x1991)
Enersys	HX205-FR (MX)	120	73	52	33	22	1	2	1790 (811.9)	1385 (628.2)	12.6x39.4x78.4 (320x1000x1991)
East Penn	HR1500 (GA)	66	38	28	16	11	1	2	1406 (637.7)	1001 (454.0)	12.6x39.4x78.4 (320x1000x1991)
East Penn	HR2000 (LA)	108	66	46	27	18	1	2	1718 (779.3)	1313 (595.6)	12.6x39.4x78.4 (320x1000x1991)

Table 9 600mm matching battery cabinet, 10-100kW with external battery cabinets

Battery Manufacturer	Battery Model	Total Backup Time in Minutes								# of Battery Cabinets	External Battery Cabinet Weight, lb (kg)	External Battery Cabinet Dimensions Each; WxDxH, in. (mm)
		10kW	15kW	20kW	30kW	40kW	60kW	80kW	100kW			
EnerSys	HX300-FR (PX)	83	52	37	21	14	7	-	-	1	2243	23.6x39.4x78.4 (600x1000x1991)
EnerSys	HX330-FR (RX)	106	65	46	26	18	9	6	-	1	2507	23.6x39.4x78.4 (600x1000x1991)
East Penn	HR3000 (PA)	83	53	38	23	16	8	5	2	1	2267	23.6x39.4x78.4 (600x1000x1991)
East Penn	HR3500 (TA)	110	70	50	31	21	11	7	4	1	2507	23.6x39.4x78.4 (600x1000x1991)
EnerSys	HX300-FR (PX)	—	127	83	53	37	21	14	10	2	4486	23.6x39.4x78.4 (600x1000x1991)
EnerSys	HX330-FR (RX)	—	—	106	66	46	27	18	12	2	5014	23.6x39.4x78.4 (600x1000x1991)
East Penn	HR3000 (PA)	—	—	83	54	38	23	16	11	2	4534	23.6x39.4x78.4 (600x1000x1991)
East Penn	HR3500 (TA)	—	—	110	70	50	31	21	15	2	5014	23.6x39.4x78.4 (600x1000x1991)

Internal batteries are not compatible with 10-40kVA UPS systems with 600mm or 880mm battery cabinets; contact your Liebert Sales representative for additional run-time options.

Table 10 880mm matching battery cabinet, 10-100kW with external battery cabinets

Battery Manufacturer	Battery Model	Total Backup Time in Minutes								# of Battery Cabinets	Weight of External Battery Cabinets, lb (kg)	External Battery Cabinet Dimensions Each; WxDxH, in. (mm)
		10kW	15kW	20kW	30kW	40kW	60kW	80kW	100kW			
EnerSys	HX400-FR (UX)	—	75	53	32	21	12	7	—	1	2751	34.7x39.4x78.4 (880x1000x1991)
EnerSys	HX505-FR (WX)	—	101	72	41	31	18	12	8	1	3303	34.7x39.4x78.4 (880x1000x1991)
EnerSys	HX540-FR (XX)	—	108	77	48	34	20	13	9	1	3375	34.7x39.4x78.4 (880x1000x1991)
East Penn	HR4000 (VA)	120	76	54	35	23	14	8	6	1	2751	34.7x39.4x78.4 (880x1000x1991)
East Penn	HR5000 (WA)	—	101	72	41	31	17	10	6	1	3183	34.7x39.4x78.4 (880x1000x1991)
East Penn	HR5500 (YA)	—	—	—	51	36	21	14	9	1	3399	34.7x39.4x78.4 (880x1000x1991)
EnerSys	HX400-FR (UX)	—	—	—	76	53	32	21	15	2	5502	34.7x39.4x78.4 (880x1000x1991)

Internal batteries are not compatible with 10-40kVA UPS systems with 600mm or 880mm battery cabinets; contact your Liebert Sales representative for additional run-time options.

SITE PLANNING DATA—LIEBERT® eXM™ 3-PHASE UPS: 10-100kVA/kW, 60Hz, 208-480VAC, BYPASS AND TRANSFORMER CABINETS

Maintenance Bypass Cabinet or Bypass Distribution Cabinet

- Provides maximum system availability to business critical equipment by allowing transfer of connected equipment to an alternate power path allowing partial or full isolation of the UPS for maintenance.
- The MBC or BDC is designed to be used with the Liebert EXM. The TXC is designed to be used with the Liebert EXM and MBC.

Maintenance Bypass Cabinet Features / Options

- Two-, three- or four-breaker configurations for the 10-100kVA UPS solutions
- Optional key interlock with SKRU

Bypass Distribution Cabinet Features / Options

- Three configurations for the 10-100kVA UPS solution
- Optional key interlock with SKRU
- Optional input isolation/voltage transformer (600/480/208V to 208/120V)
- Optional (1) 225A panelboard (10-40kVA)
- Optional (1) 400A panelboard (60-100kVA)
- Optional (2) 225A subfeed breakers (60-100kVA)
- Optional distribution branch and subfeed monitoring

Table 11 Maintenance Bypass Cabinet

MBC / UPS Size	Voltage		Input Isolation Transformer	Bypass Isolation Transformer	Output Distribution	Heat Dissipation BTU/hr (kW)	WxDxH in. (mm)	Weight lb (kg)
	Input	Output						
200 mm / 10-40kVA	208/120	208/120	No	No	No	N/A	7.9x39.4x78.4 (201x1000x1991)	198 (89.8)
300 mm / 60-100kVA	208/120	208/120	No	No	No	N/A	11.8x39.4x78.4 (300x1000x1991)	298 (135.2)

Table 12 Bypass Distribution Cabinet

BDC / UPS Size	Voltage		Input Isolation Transformer	Input Single / Dual	Output Distribution	Heat Dissipation BTU/HR (kW)	Dimensions WxDxH, in. (mm)	Weight lb (kg)
	Input	Output						
600mm / 10-100kVA	208/120	208/120	No	Single or Dual	Yes	N/A	23.6x39.4x78.4 (600x1000x1991)	660 (299.4)
600mm / 10kVA	480	208/120	Yes	Single	Yes	1638 (0.5)	23.6x39.4x78.4 (600x1000x1991)	1210 (548.8)
600mm / 15kVA	480	208/120	Yes	Single	Yes	2013 (0.6)	23.6x39.4x78.4 (600x1000x1991)	1210 (548.8)
600mm / 20kVA	480	208/120	Yes	Single	Yes	2733 (0.8)	23.6x39.4x78.4 (600x1000x1991)	1210 (548.8)
600mm / 30kVA	480	208/120	Yes	Single	Yes	4948 (1.5)	23.6x39.4x78.4 (600x1000x1991)	1210 (548.8)
600mm / 40kVA	480	208/120	Yes	Single	Yes	5343 (1.6)	23.6x39.4x78.4 (600x1000x1991)	1210 (548.8)
600mm / 60kVA	480	208/120	Yes	Single	Yes	6,855 (2.0)	23.6x39.4x78.4 (600x1000x1991)	1632 (740.3)
600mm / 80kVA	480	208/120	Yes	Single	Yes	9513 (2.8)	23.6x39.4x78.4 (600x1000x1991)	1632 (740.3)
600mm / 100kVA	480	208/120	Yes	Single	Yes	10,608 (3.1)	23.6x39.4x78.4 (600x1000x1991)	1632 (740.3)

Table 13 Transformer Cabinet—Dual Input XFMR with isolation

Transformer Cabinet/UPS Size	Voltage		Input Isolation Transformer	Bypass Isolation Transformer	Heat Dissipation BTU/hr (kW)	Dimensions WxDxH,in. (mm)	Weight lb (kg)
	Rectifier/Bypass	Output					
600mm/10kVA	480	208/120	Yes	Yes	3276 (1.0)	23.6x39.4x78.4 (600x1000x1991)	906 (411)
600mm/15kVA	480	208/120	Yes	Yes	4026 (1.2)	23.6x39.4x78.4 (600x1000x1991)	938 (425)
600mm/20kVA	480	208/120	Yes	Yes	5466 (1.6)	23.6x39.4x78.4 (600x1000x1991)	1032 (468)
600mm/30kVA	480	208/120	Yes	Yes	9896 (2.9)	23.6x39.4x78.4 (600x1000x1991)	1298 (589)
600mm/40kVA	480	208/120	Yes	Yes	10,686 (3.1)	23.6x39.4x78.4 (600x1000x1991)	1324 (601)
600mm/60kVA	480	208/120	Yes	Yes	13,710 (4.0)	23.6x39.4x78.4 (600x1000x1991)	1604 (728)
600mm/80kVA	480	208/120	Yes	Yes	19,026 (5.6)	23.6x39.4x78.4 (600x1000x1991)	1846 (837)
600mm/100kVA	480	208/120	Yes	Yes	21,216 (6.2)	23.6x39.4x78.4 (600x1000x1991)	2066 (937)

SITE PLANNING DATA—COMMON LINEUPS LIEBERT® EXM™ 3-PHASE 10-100kVA/kW, 208-480VAC

Common Configurations 10-40kVA

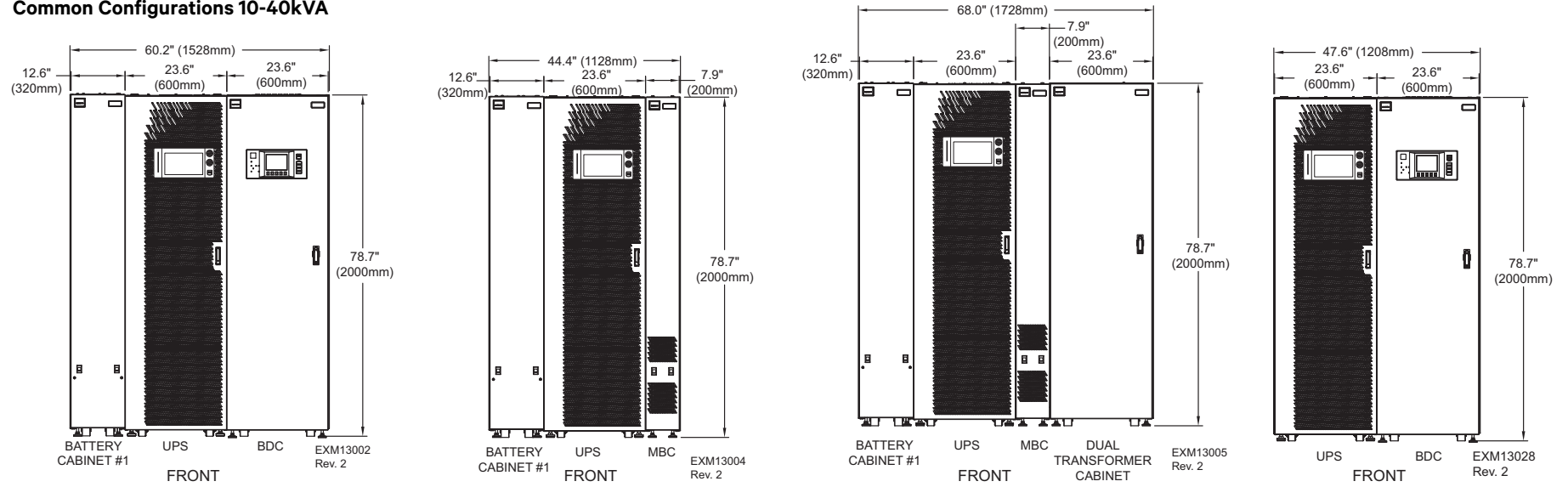

Common Configurations 60-100kVA

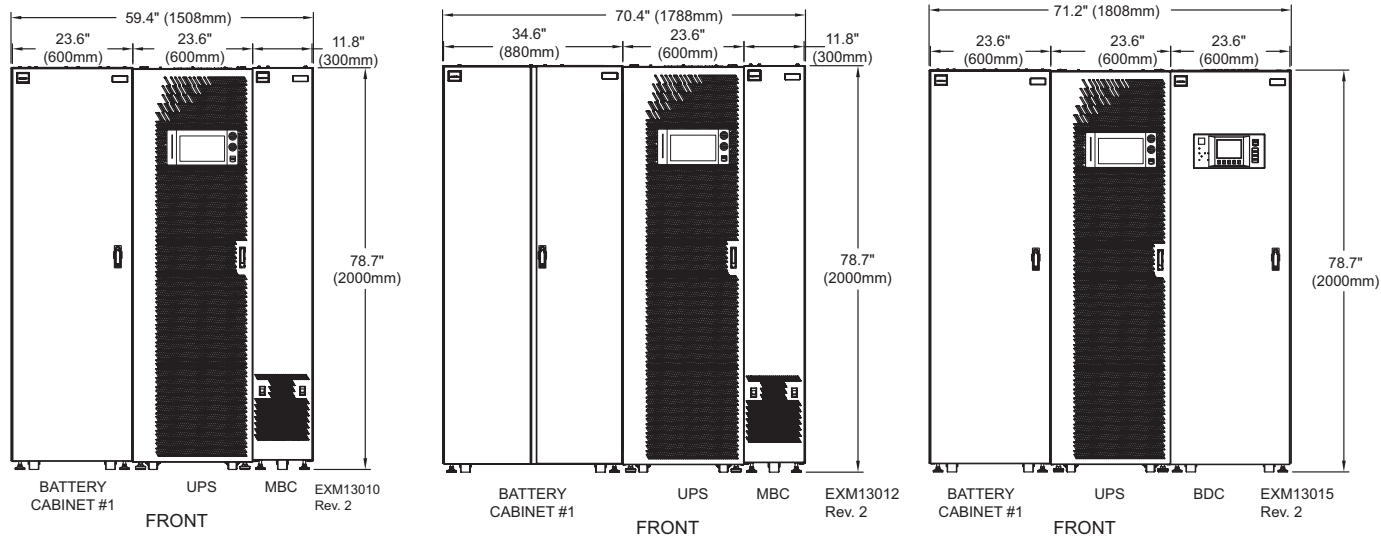

SITE PLANNING DATA—LIEBERT® eXM™ 3-PHASE UPS AND BATTERY SPECIFICATIONS

Table 14 General specifications

INPUT		OUTPUT	
Voltage	208/120, 220/127VAC, 50/60Hz, 3-phase, 4-wire plus ground	Voltage	208/120, 220/127VAC, 50/60Hz, 3-phase, 4-wire plus ground
Voltage Range without derating	+15%, -20%	Voltage Adjustment Range	±5%
Frequency Range	40-70Hz	Voltage Regulation	1% for balanced load; 5% regulation for unbalanced load
THDi (Current Distortion)	5% maximum reflected THD at full load	Dynamic Regulation	±5% deviation for 100% load step ±1% for loss or return of AC input
Power Factor	0.99 full load, 0.98 half load	Transient Response Time	Recover to ±5% of output voltage within 1/2 cycle
Surge Protection	Withstands input surges w/o damage, per criteria in IEC 1000-4-5 (w/ surge suppressor option ANSI C62.41 (IEEE 587) CAT A3 & B3)	THDv	For linear loads, 2% THD; Less than 5% THD for 100% nonlinear loads without kVA/kW derating
ENVIRONMENTAL		Phasing Balance	120° ±1° for balanced load 120° ±1.5° for 100% unbalanced load
Operating Temperature	UPS: 32° to 104°F (0-40°C) Battery: 68° to 86°F (20-30°C)	Frequency Regulation	±0.1% to ±0.25%
Non-Operating Temperature	-4° to 158°F (-20° to 70°C)	Load Power Factor Range	0.5 lagging to 0.9 leading without derating
Relative Humidity	0-95% non-condensing	Overload	100% load, continuous 110% load, 60 minutes; 125% load, 10 minutes; 150% load, 60 seconds, with true sinusoidal waveform
Operating Altitude	Up to 3,300 ft. (1,000m) without derating		
Acoustical Noise	Less than 59 dBA typical (100kVA) Acoustical Noise, at 55 in. (1.4m)		
STANDARDS			
	Listed to UL 1778 UPS standards, and CSA certified. Meets current requirements for safe, high performance UPS operation.		

Notes for Tables

- Nominal (Nom) current is based on full rated output load at nominal input voltage.
- Maximum (Max) current (125% of nominal) is short duration for battery recharge conditions.
- UPS input and bypass cables must be run in separate conduit from output cables.
- Nominal battery voltage is shown at 2.0 volts/cell per NEC 480-2.
- Nominal rectifier AC input current (considered continuous) is based on full rated output load. Maximum current includes nominal input current and maximum battery recharge current (considered non-continuous). Continuous and non-continuous currents are defined in NEC 215.
- Nominal AC output current (considered continuous) is based on full rated output load. Output breakers are either supplied by the customer or by using the optional Liebert Bypass Distribution Cabinet.
- Minimum-sized grounding conductors to be per NEC 250-122. Parity-sized ground conductors are recommended. Neutral conductors to be sized for full capacity per NEC 310-15 (b)(4). References are per NEC 2008.
- Wiring requirements: AC Input: 3-phase, 4-wire, plus ground
AC Output: 3-phase, 3- or 4-wire, plus ground
- All wiring is to be in accordance with national and local electric codes.
- Minimum access clearance is 36" (914mm) front; ventilation clearance is 24" (610mm) above and 0-5" (127mm) in the rear, depending on anchoring method.
- Top or bottom cable entry through removable access plates. Punch plate to suit conduit size, then replace.
- Control wiring and power wiring must be run in separate conduit.
- Dimensions shown include an internal battery (40kVA frame only).
- Weights shown do not include an internal battery nor optional cabinets or features.
- When a Liebert Bypass Distribution Cabinet is not used, the customer must supply the input circuit breaker with a 120VAC shunt trip on the bypass and rectifier feed. The shunt trip drive capability is 8A.
- If site configuration includes a backup emergency generator, Vertiv® recommends that the engine generator set be properly sized and equipped for a UPS application. Generator options would typically include an isochronous governor (generator frequency regulation) and a UPS-compatible regulator (generator voltage regulation). Consult generator manufacturer for required generator options and sizing.
- If site configuration includes an automatic transfer switch, refer to Liebert Power Line titled "Criteria for Application of Automatic Transfer Switches (ATS) With Uninterruptible Power Supply (UPS) Systems," publication 91K-PLT-48-02. It is also recommended that the transfer switch be equipped with auxiliary contacts to provide a UPS "on generator" signal. Consult transfer switch manufacturer for required transfer switch options and sizing.
- If site configuration requires an external isolated maintenance bypass circuit, it should be noted that utility AC input might not be in phase with the UPS AC output. Consult your Vertiv sales representative or applications engineer.



© 2014 Liebert Corporation
All rights reserved throughout the world. Specifications subject to change without notice.
* Liebert is a registered trademark of Liebert Corporation.
All names referred to are trademarks or registered trademarks of their respective owners.
SL-25645_REV2_12-16

Technical Support / Service
800-543-2378
powertech@vertivco.com
Web site: www.liebert.com

United States
1050 Dearborn Drive
P.O. Box 29186
Columbus, OH 43229