

LIEBERT® NXL™ 625-1100kVA, 1+1 (DISTRIBUTED BYPASS) MULTI-MODULE SYSTEM SITE PLANNING DATA

Table 1 Site planning data—625-1100kVA

UPS Rating		AC Input/Output Voltage, VAC	Input Isolation Transformer	Rectifier AC Input Current		Bypass/Output AC Output Current	Maximum Battery Current at End of Discharge (A)	Maximum Heat Dissipation Full Load, BTU/h (kW)	Dimensions WxDxH, in. (mm)	Approximate Weight Unpacked, lb. (kg)
kVA	kW			Nom	Max	Nom				
625	625	480	YES	907	952	752	1715	195,742 (57.4)	140.5x39.4x76.8 (3568x1000x1950)	12,980 (5888)
625	625	575		757	795	628		183,079 (53.7)		
625	625	600		726	762	601				
800	800	480	NO	1139	1195	962	2061	177,240 (51.9)	184.8x47.2x78.7 (4694x1200x2000)	16,120 (7312)
1100	1100	480	YES	1534	1611	1323	2853	252,540 (74.0)	228.3x47.2x78.7 (5800x1200x2000)	21,450 (9730)
1100	1100	575		1313	1379	1104	2860	264,714 (77.6)		
1100	1100	600		1252	1314	1058	2856	254,817 (74.7)		
See Notes below:			—	1,3,6,7,8,10,11		2,3,4,6,7,8,10,11,13	5,6,7,8,10,11	—	9, 12	9,12

Notes for Table 1

- Nominal rectifier AC input current (considered continuous) is based on full rated output load. Maximum current includes nominal input current and maximum battery recharge current (considered non-continuous). Maximum input current is controlled by current limit setting, which is adjustable 25 to 150% of nominal input current.
- Bypass AC input and AC output current (considered continuous) is based on full rated output load. Maximum current includes nominal output current and 125% overload current for 10 minutes.
- Emerson recommends that feeder protection (by others) for the rectifier AC input and the bypass AC input be provided by separate overcurrent protection devices.
- UPS output load cables must be run in separate conduit from input cables.
- Power cable from module DC bus to battery should be sized for a total maximum 2.0V line drop (power cable drop plus return cable drop as measured at the module) at maximum discharge current.
- Grounding conductors to be sized per NEC 250-95. Neutral conductors to be sized for full capacity per NEC 310-16, Note 10 for systems with 4-wire loads and 20% minimum capacity for 3-wire loads.
- Rectifier AC Input: 3-phase, 3-wire, plus ground
Bypass AC Input: 3-phase, 4-wire, plus ground (3-wire plus ground in certain circumstances)
AC Output to Load: 3-phase, 3- or 4-wire, plus ground
Module DC Input from Battery: 2-wire (positive and negative), plus ground
- All wiring is to be in accordance with national and local electrical codes.
- Minimum overhead clearance is 2 ft. (0.6m) above the UPS.
- Top or bottom cable entry through removable access plates. Cut plate to suit conduit size.
- Control wiring and power cables must be run in separate conduits. Control wiring must be stranded tinned conductors.
- Dimensions and weights do not include the System Paralleling Cabinet.
- For optimal load sharing performance, the difference in bypass circuit cable length must be 10% or less from longest to shortest. Cable length should be measured from common point of input to common point of output. If needed, contact your Emerson representative to determine if other lengths are acceptable.

NOTE: A neutral conductor is required from each multi-module unit output to the system paralleling switchboard.



Numbers in this illustration refer to notes below the table on page 1

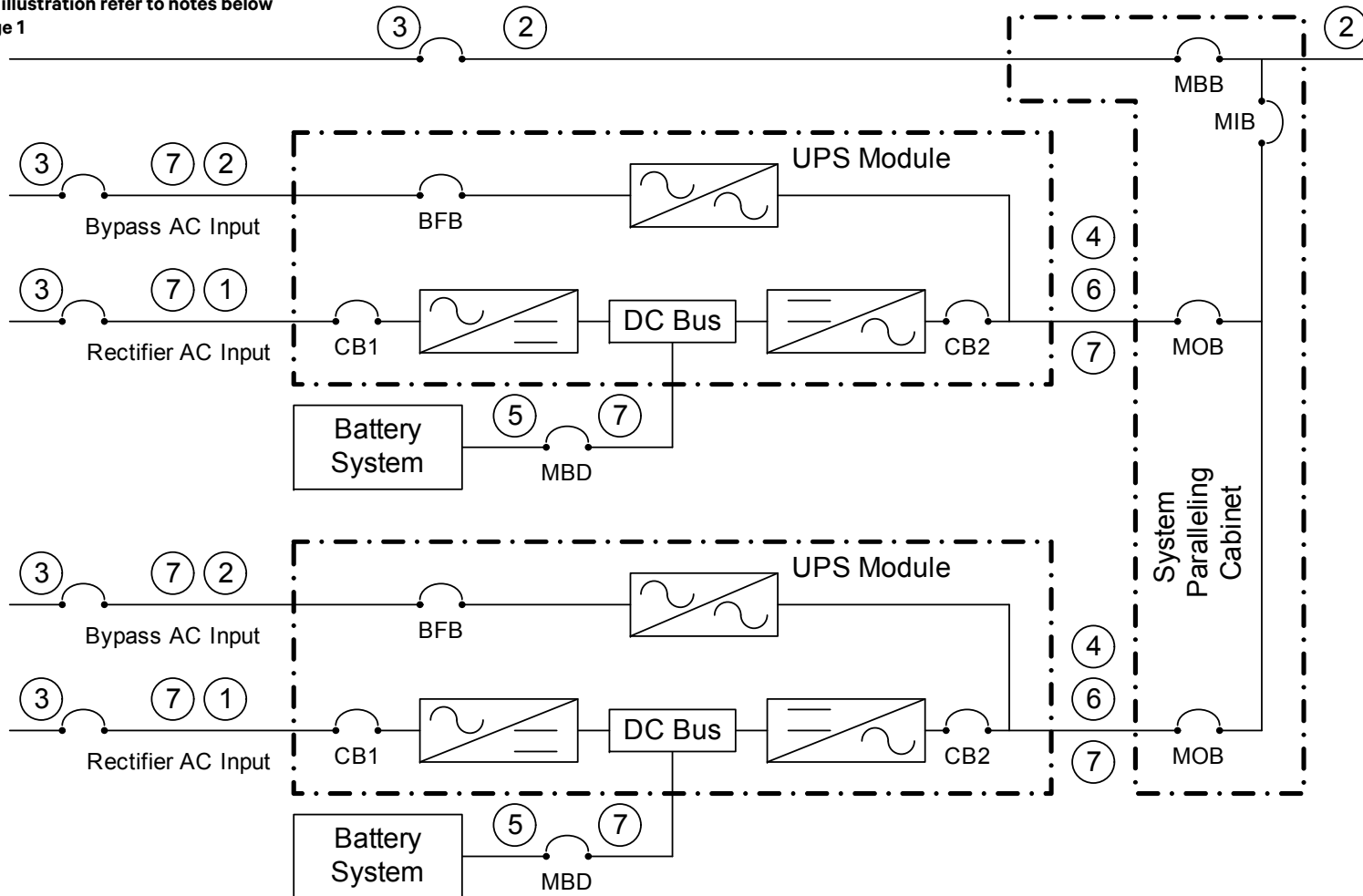

The Liebert NXL is compatible with high resistance ground systems. See your local Emerson representative for details.



© 2014 Liebert Corporation
 All rights reserved throughout the world. Specifications subject to change without notice.
 * Liebert is a registered trademark of Liebert Corporation.
 All names referred to are trademarks or registered trademarks of their respective owners.
 SL-25532_REV2_02-17

Technical Support / Service

800-543-2378
 powertech@vertivco.com
 Web site: www.liebert.com

United States

1050 Dearborn Drive
 P.O. Box 29186
 Columbus, OH 43229