



# Liebert® NXL™ UPS

Installation Manual — 500-750kVA, 0.9PF, 60Hz, Three-Phase, Single-Module & Multi-Module

---

## CONTACTING VERTIV FOR SUPPORT

---

To contact Vertiv Liebert® Services for information or repair service in the United States, call 800-543-2378. Liebert Services offers a complete range of start-up services, repair services, preventive maintenance plans and service contracts.

For repair or maintenance service outside the 48 contiguous United States, contact Liebert Services, if available in your area. For areas not covered by Liebert Services, the authorized distributor is responsible for providing qualified, factory-authorized service.

For Liebert Services to assist you promptly, please have the following information available:

Part numbers: \_\_\_\_\_

Serial numbers: \_\_\_\_\_

Rating: \_\_\_\_\_

Date purchased: \_\_\_\_\_

Date installed: \_\_\_\_\_

Location: \_\_\_\_\_

Input voltage/frequency: \_\_\_\_\_

Output voltage/frequency: \_\_\_\_\_

Battery reserve time: \_\_\_\_\_

### Product Warranty Registration

To register for warranty protection, visit the Service and Support section of our Web site at:

[www.liebert.com](http://www.liebert.com)

Click on Product Registration and fill out the form.

©2016 Vertiv Co. All rights reserved throughout the world.

This document may contain confidential and/or proprietary information of Liebert Corporation, and its receipt or possession does not convey any right to reproduce, disclose its contents, or to manufacture or sell anything that it may describe. Reproduction, disclosure, or use without specific authorization from Liebert Corporation is strictly prohibited.

---

---

# TABLE OF CONTENTS

<b>IMPORTANT SAFETY INSTRUCTIONS</b> .....	<b>1</b>
<b>1.0 MECHANICAL INSTALLATION</b> .....	<b>3</b>
1.1 Introduction .....	3
1.2 Preliminary Checks .....	3
1.3 Environmental Considerations .....	3
1.3.1 UPS Room .....	3
1.3.2 Storing the UPS and Batteries for Delayed Installation .....	4
1.4 Positioning .....	4
1.4.1 Moving the Cabinets .....	4
1.4.2 Clearances .....	5
1.4.3 Raised-Floor Installations .....	5
1.4.4 Kick Plate Installation .....	5
1.4.5 Special Considerations for 1+N Parallel Systems .....	5
1.5 System Composition .....	5
1.6 Cable Entry .....	6
<b>2.0 UPS ELECTRICAL INSTALLATION</b> .....	<b>7</b>
2.1 External Protective Devices .....	7
2.2 Power Cables .....	7
2.3 Sizing the Input Breaker feeding a Liebert NXL UPS .....	8
2.3.1 Power Cable Connection Procedure .....	8
2.4 Control Cable and Communication .....	10
2.4.1 Dry Contacts .....	10
2.4.2 Multi-Module Communication .....	12
2.4.3 Remote Input Breaker (RIB) .....	13
2.4.4 Inverter Output Breaker (IOB) .....	14
2.5 Digital LBS .....	16
2.6 Configuring Neutral and Ground Connections .....	17
2.6.1 Four-Wire Input connections .....	17
2.6.2 Three-Wire Input connections .....	17
2.6.3 Preferred Grounding Configuration, Battery Systems .....	17
2.6.4 Multi-Module Systems .....	18
2.6.5 High Resistance Ground Systems .....	18
2.7 Grounding Diagrams, Single- and Multi-Module Systems .....	18
<b>3.0 OPTIONAL EQUIPMENT</b> .....	<b>21</b>
3.1 Single-Module System Options .....	21
3.1.1 Matching Maintenance Bypass Cabinet .....	21
3.1.2 Battery Temperature Sensor .....	21
3.1.3 Matching Liebert NXL Battery Cabinet .....	21
3.1.4 Matching Module Battery Disconnect—MBD .....	21
3.1.5 Load Bus Synch .....	21
3.1.6 Remote Alarm Status Panel .....	21

3.2	Communication and Monitoring .....	21
3.2.1	Alber Monitoring System.....	21
3.2.2	Programmable Relay Board.....	22
3.2.3	Input Contact Isolator Board .....	24
<b>4.0</b>	<b>INSTALLATION DRAWINGS.....</b>	<b>26</b>
4.1	Programmable Relay Board.....	54
<b>5.0</b>	<b>SPECIFICATIONS.....</b>	<b>55</b>

## FIGURES

Figure 1	Cabinet arrangement—Liebert NXL, battery cabinets, maintenance bypass cabinet .....	6
Figure 2	Cabinet EMI plates - 625kVA and 750kVA only .....	9
Figure 3	Kick plate and filter locations .....	9
Figure 4	Low-voltage cable installation—top entry .....	9
Figure 5	External Interface Board connections layout .....	10
Figure 6	Inter-Module Communication Board wiring diagram—Multi-modules.....	12
Figure 7	Remote Input Breaker diagram.....	13
Figure 8	Remote Output Breaker diagram.....	15
Figure 9	Inter-Module Communication Board wiring diagram—Digital LBS .....	16
Figure 10	Grounding diagram, three-wire single-module system .....	18
Figure 11	Grounding diagram, four-wire single-module system.....	18
Figure 12	Grounding diagram, three-wire multi-module system .....	19
Figure 13	Grounding diagram, four-wire multi-module system .....	20
Figure 14	Control wiring, Programmable Relay Board .....	22
Figure 15	Programmable relay board dialog box.....	23
Figure 16	Input contact isolator dialog box.....	24
Figure 17	Optional Input Contact Isolator Board.....	25
Figure 18	Main components, 500kVA Liebert NXL SMS and 1+N multi-module unit with static bypass ...	26
Figure 19	Outline drawing, Liebert NXL 500kVA UPS SMS and 1+N multi-module unit with static bypass.....	27
Figure 20	Input terminal details, Liebert NXL 500kVA UPS, SMS and 1+N multi-module unit with static bypass.....	28
Figure 21	Output terminal details, Liebert NXL 500kVA UPS, SMS and 1+N multi-module unit with static bypass.....	29
Figure 22	Base drawing, Liebert NXL 500kVA UPS, SMS and 1+N multi-module unit with static bypass.....	30
Figure 23	Field connections, shipping split 500kVA Liebert NXL, multi-module or SMS with static bypass, Page 1 .....	31
Figure 24	Field connections, shipping split 500kVA Liebert NXL, multi-module or SMS with static bypass, Page 2 .....	32
Figure 25	Main components, 625/750kVA Liebert NXL, N+1 multi-module unit without static bypass.....	34
Figure 26	Main components, 625/750kVA Liebert NXL UPS, SMS and 1+N multi-module unit with static bypass.....	35
Figure 27	Outline drawing, 625/750kVA Liebert NXL, N+1 multi-module unit without static bypass.....	36
Figure 28	Outline Drawing, 625/750kVA Liebert NXL, SMS and 1+N multi-module unit with static bypass.....	37

Figure 29	Base detail drawing, 625/750kVA Liebert NXL, N+1 multi-module unit without static bypass . . .	38
Figure 30	Base Drawing, 625/750kVA Liebert NXL, SMS and 1+N multi-module unit with static bypass. . .	39
Figure 31	Input terminal detail, 625/750kVA Liebert NXL, N+1 multi-module unit without static bypass. . . . .	40
Figure 32	Input terminal detail, 625/750kVA Liebert NXL, SMS and 1+N multi-module unit with static bypass. . . . .	41
Figure 33	Output terminal detail, 625/750kVA Liebert NXL, N+1 multi-module unit without static bypass, <i>cont'd</i> . . . . .	42
Figure 34	Output terminal detail, 625/750kVA Liebert NXL, SMS and 1+N multi-module unit with static bypass, <i>cont'd</i> . . . . .	43
Figure 35	Shipping split 625/750kVA Liebert NXL without static bypass . . . . .	44
Figure 36	Shipping split 625/750kVA Liebert NXL without static bypass ( <i>continued</i> ). . . . .	46
Figure 37	Shipping Split, 625/750kVA Liebert NXL, SMS and 1+N multi-module unit with static bypass. . . . .	48
Figure 38	Shipping Split, 625/750kVA Liebert NXL, SMS and 1+N multi-module unit with static bypass, <i>continued</i> . . . . .	50
Figure 39	Single-input wire cabinet . . . . .	52
Figure 40	Alternate Liebert NXL 500kVA bottom cable entry . . . . .	53
Figure 41	Control wiring, Programmable Relay Board . . . . .	54
Figure 42	Inverter overload data . . . . .	59
Figure 43	Bypass overload data . . . . .	60

## TABLES

Table 1	UPS input dry contacts. . . . .	10
Table 2	UPS control contacts with global maintenance bypass. . . . .	11
Table 3	UPS control contacts to remote status panel . . . . .	11
Table 4	UPS control contacts with battery cabinet or module battery disconnect. . . . .	11
Table 5	Parallel from UPS module Inter-Module Communication Board to other Inter-Module Communication Board in system. . . . .	12
Table 6	RIB UV coil, aux. contacts from UPS RIB CB interface board to remote CB1 . . . . .	14
Table 7	Remote IOB contacts from remote breaker to UPS IOB CB interface board. . . . .	15
Table 8	Wire size, length for digital LBS connection of UPS Inter-Module Communication Boards . . . . .	16
Table 9	Programmable Relay Board pinout . . . . .	22
Table 10	Input Contact Isolator Board pre-assigned values . . . . .	25
Table 11	Input Contact Isolator Board control wiring connections . . . . .	25
Table 12	Programmable Relay Board pinout . . . . .	54
Table 13	Liebert NXL UPS specifications. . . . .	55
Table 14	Current ratings—rectifier input . . . . .	56
Table 15	Current ratings—bypass input. . . . .	57
Table 16	Current ratings—output . . . . .	57
Table 17	Current ratings—battery . . . . .	57
Table 18	Recommended conduit and cable sizes . . . . .	58
Table 19	Recommended torque values . . . . .	61
Table 20	Recommended lug sizes. . . . .	61



# IMPORTANT SAFETY INSTRUCTIONS

## SAVE THESE INSTRUCTIONS

This manual contains important instructions that should be followed during installation of your Liebert NXL UPS. Read this manual thoroughly, paying special attention to the sections that apply to your installation, before working with the UPS. Retain this manual for use by installing personnel.

### **WARNING**

Risk of electrical shock. Can cause personal injury or death.

This UPS has several circuits that are energized with high DC as well as AC voltages. Check for voltage with both AC and DC voltmeters before working within the UPS. Check for voltage with both AC and DC voltmeters before making contact.

Only properly trained and qualified personnel wearing appropriate safety headgear, gloves, shoes and glasses should be involved in installing the UPS or preparing the UPS for installation. When performing maintenance with any part of the equipment under power, service personnel and test equipment should be standing on rubber mats.

In case of fire involving electrical equipment, use only carbon dioxide fire extinguishers or those approved for use in fighting electrical fires.


Extreme caution is required when performing installation and maintenance.

Special safety precautions are required for procedures involving handling, installation and maintenance of the UPS system. Observe all safety precautions in this manual before handling or installing the UPS system. Observe all precautions in the Operation and Maintenance Manual, SL-25425, before as well as during performance of all maintenance procedures. Observe all DC safety precautions before working on or near the DC system.

### **WARNING**

Risk of heavy unit falling over. Improper handling can cause equipment damage, injury or death.

Exercise extreme care when handling UPS cabinets to avoid equipment damage or injury to personnel. The UPS module weight is up to 13,800lb. (6260kg).

Locate center of gravity symbols  and determine unit weight before handling each cabinet. Test lift and balance the cabinets before transporting. Maintain minimum tilt from vertical at all times.

Slots at the base of the module cabinets are intended for forklift use. Base slots will support the unit only if the forks are completely beneath the unit.

Read all of the following instructions before attempting to move, lift, or remove packaging from unit, or prepare unit for installation.

### **WARNING**

Risk of electrical shock and fire. Can cause equipment damage, personal injury or death.

Under typical operation and with all UPS doors closed, only normal safety precautions are necessary. The area around the UPS system should be kept free of puddles of water, excess moisture and debris.

Only test equipment designed for troubleshooting should be used. This is particularly true for oscilloscopes. Always check with an AC and DC voltmeter to ensure safety before making contact or using tools. Even when the power is turned Off, dangerously high potential electric charges may exist at the capacitor banks and at the DC connections.

All wiring must be installed by a properly trained and qualified electrician. All power and control wiring must comply with all applicable national, state and local codes.

One person should never work alone, even if all power is disconnected from the equipment. A second person should be standing by to assist and to summon help in case of an accident.



## **NOTE**

*Materials sold hereunder cannot be used in the patient vicinity (e.g., use where UL, cUL or IEC 60601-1 is required). Medical applications such as invasive procedures and electrical life support equipment are subject to additional terms and conditions.*

## **NOTICE**

This unit complies with the limits for a Class A digital device, pursuant to Part 15 Subpart J of the FCC rules. These limits provide reasonable protection against harmful interference in a commercial environment. This unit generates, uses and radiates radio frequency energy and, if not installed and used in accordance with this instruction manual, may cause harmful interference to radio communications. Operation of this unit in a residential area may cause harmful interference that the user must correct at his own expense.



# 1.0 MECHANICAL INSTALLATION

## 1.1 INTRODUCTION

This section describes the requirements that must be taken into account when planning the positioning and cabling of the Liebert NXL uninterruptible power supply and related equipment.

This chapter is a guide to general procedures and practices that should be observed by the installing personnel. The particular conditions of each site will determine the applicability of such procedures.

### **WARNING**

Risk of electrical shock. Can cause injury or death.

Special care must be taken when working with the batteries associated with this equipment. When they are connected together, the battery terminal voltage will exceed 400VDC and is potentially lethal.



### **NOTE**

*All equipment not referred to in this manual is shipped with details of its own mechanical and electrical installation.*

### **NOTICE**

Three-phase input supply required.

The standard Liebert NXL UPS is suitable for connection to three-phase, four-wire (+ Earth) TN-C, TN-S, IT-G or IT-IG, or three-phase, three-wire plus ground IT-UG.

If the unit is used with an IT power system, a 4-pole disconnect device must be included as part of building installation.

### **NOTICE**

Do not apply electrical power to the UPS equipment before the arrival of the commissioning engineer.

## 1.2 PRELIMINARY CHECKS

Before installing the UPS, please carry out the following preliminary checks:

- Visually examine the UPS equipment for transit damage, both internally and externally. Report any damage to the shipper immediately.
- Verify that the correct equipment is being installed. The equipment supplied has an identification tag on the interior doors reporting the type, size and main calibration parameters of the UPS.
- Verify that the UPS room satisfies the environmental conditions stipulated in the equipment specification, paying particular attention to the ambient temperature and air exchange system.

## 1.3 ENVIRONMENTAL CONSIDERATIONS

### 1.3.1 UPS Room

The UPS module is intended for indoor installation and should be located in a cool, dry, clean-air environment with adequate ventilation to keep the ambient temperature within the specified operating range (see **Environmental Parameters** in **Table 13**).

The Liebert NXL UPS is cooled with the aid of internal fans. To permit air to enter and exit and prevent overheating or malfunctioning, do not cover the ventilation openings.



### **NOTE**

*To ensure proper airflow, the unit must be installed only on a solid surface made of a noncombustible material, such as concrete.*

The Liebert NXL UPS is equipped with air filters located behind the front doors. A schedule for inspection of the air filters is required. The period between inspections will depend upon environmental conditions.

When bottom entry is used, the conduit plate must be installed.



### **NOTE**

*The UPS is suitable for mounting on concrete or other non-combustible surface only.*

### 1.3.2 Storing the UPS and Batteries for Delayed Installation

If the Liebert NXL system will not be installed immediately, it must be stored indoors in a clean, dry and cool location (see **Environmental Parameters** in **Table 13**). If the UPS includes batteries, either internally or in a battery cabinet, the batteries' requirements will dictate the storage conditions. Batteries should be unpacked, installed and charged as soon as possible after delivery.

#### NOTICE

Risk of failure to properly charge batteries. Can cause permanent damage to batteries and void the warranty.

Batteries will self-discharge during storage. Batteries must be recharged as recommended by the battery manufacturer.

A notice of "Charge Before Date" is affixed to each unit that has batteries inside. The "Charge Before Date" is calculated based on the batteries being stored at 77°F (25°C). Storage at a higher temperature will increase the rate of self-discharge, requiring earlier recharge. Consult the battery manufacturer on how to determine when the batteries need to be recharged.

## 1.4 POSITIONING

The cabinet is structurally designed to handle lifting from the base.

Access to the power terminals, auxiliary terminal blocks and power switches is from the front.

The door can be opened to give access to the power connection bars, auxiliary terminal blocks and power isolators. Front door can be opened at 180 degrees, and interior doors can be removed for more flexibility in installations.



#### NOTE

*The UPS must be placed a solid surface. There must be no openings in the surface except those required for conduit landing areas. All provided kick plates must be installed.*

### 1.4.1 Moving the Cabinets

The route to be travelled between the point of arrival and the unit's position must be planned to make sure that all passages are wide enough for the unit and that floors are capable of supporting its weight (for instance, check that doorways, lifts, ramps, etc. are adequate and that there are no impassable corners or changes in the level of corridors).

Ensure that the UPS weight is within the designated surface weight loading (kg/cm<sup>2</sup>) of any handling equipment. For weight details, see **Table 13**.

The UPS can be handled with a forklift or similar equipment. Ensure any lifting equipment used in moving the UPS cabinet has sufficient lifting capacity. When moving the unit by forklift, care must be taken to protect the panels. Do not exceed a 15-degree tilt with the forklift. Bottom structure will support the unit only if the forks are completely beneath the unit.

Handling with straps is not authorized.




## WARNING

Risk of heavy unit falling over. Improper handling can cause equipment damage, injury or death.

Because the weight distribution in the cabinet is uneven, use extreme care while handling and transporting. Take extreme care when handling UPS cabinets to avoid equipment damage or injury to personnel.

The UPS module weight is up to 13,800lb. (6260kg).

Locate center of gravity symbols  and determine unit weight before handling each cabinet. Test lift and balance the cabinets before transporting. Maintain minimum tilt from vertical at all times.

### 1.4.2 Clearances

The Liebert NXL has no ventilation grilles at either side or at the rear of the UPS. Clearance around the front of the equipment should be sufficient to enable free passage of personnel with the doors fully opened. It is important to leave a distance of 24in (610mm) between the top of the UPS and any overhead obstacles to permit adequate circulation of air coming out of the unit.

### 1.4.3 Raised-Floor Installations

If the equipment is to be located on a raised floor, it should be mounted on a pedestal suitably designed to accept the equipment point loading. Refer to the base view to design this pedestal. The top of the pedestal must be solid.



#### NOTE

*The UPS must be placed on a solid surface. There must be no openings in the surface except those required for conduit landing areas. All provided kick plates must be installed.*

### 1.4.4 Kick Plate Installation

Kick plates must be installed. If the unit is to be installed in a position that does not permit access to rear kick plates, then the kick plates must be installed before the unit is placed in its final position.

### 1.4.5 Special Considerations for 1+N Parallel Systems

Consider the grounding configuration of your system before finalizing module placement. See **2.6 - Configuring Neutral and Ground Connections**.

Vertiv recommends matching the impedance in the bypass path of paralleled systems as closely as possible.

The impedance mismatch can be minimized by controlling the wiring length of each unit. The design and the layout of the UPS system and associated panels and cabling should be examined closely to ensure that cable lengths and impedances are closely matched. The Liebert 1+N UPS module is supplied with a sharing reactor to minimize the impact of cable impedance mismatch.

The cabling impedance must be carefully controlled to ensure good bypass current sharing.

For Liebert NXL™ Systems, the cabling impedances must be within 10% from maximum to minimum. If the cabling impedances need to be greater than 10%, contact your Vertiv representative to calculate whether the system will result in an overload condition when operating on bypass.

When bringing the 1+N system online for the first time or after removing one unit, Vertiv recommends checking the bypass current mismatch. To check the bypass current mismatch:

1. Place a load on the bypass of each UPS module.
2. View the output current of each unit.

The accuracy of the currents displayed on the UPS module is sufficient for this check. If the mismatch is greater than 10%, the bypass impedances must be balanced or the load must be limited to less than the maximum rating.

## 1.5 SYSTEM COMPOSITION

A UPS system can comprise a number of equipment cabinets, depending on the individual system design requirements: e.g., UPS cabinet, battery cabinet, maintenance bypass cabinet. In general, all the cabinets used in a particular installation are of the same height. Refer to the drawings provided in **4.0 - Installation Drawings** for the positioning of the cabinets as shown in **Figure 1**.

## 1.6 CABLE ENTRY

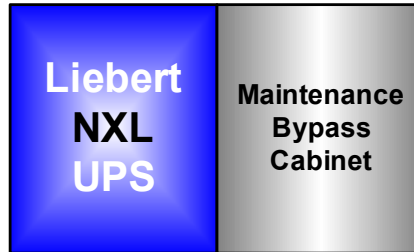
Cables can enter the UPS cabinet from bottom or top into the Input/Output (I/O) section of the unit; see the figures in **4.0 - Installation Drawings**.

**Figure 1 Cabinet arrangement—Liebert NXL, battery cabinets, maintenance bypass cabinet**

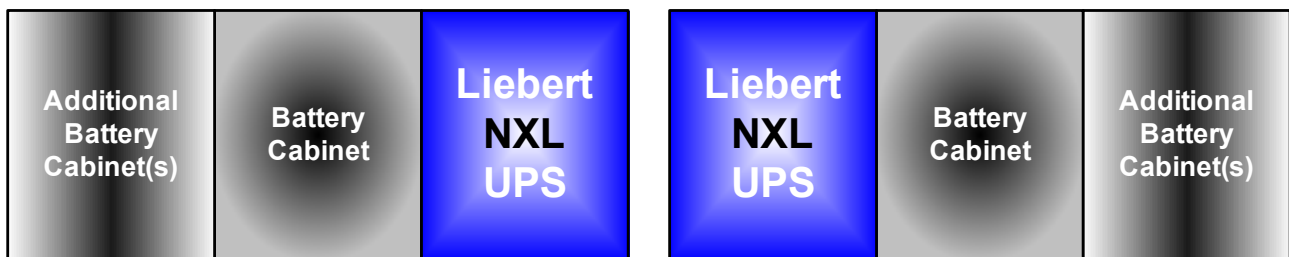
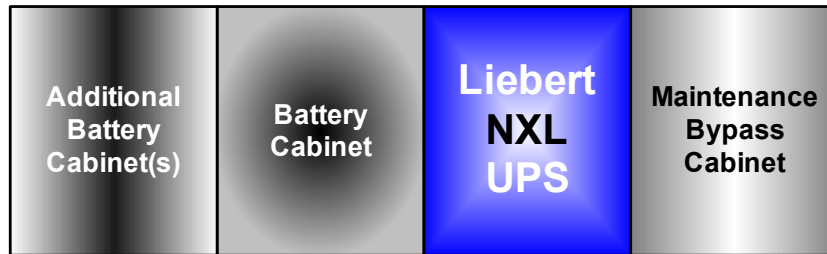
The side panels and hangers must be removed before the cabinets can be bolted together.



Note: Battery cabinets can be bolted to the right of the UPS. However, the cabling must be routed externally.



Note: If a maintenance bypass cabinet is used, it must be installed on the right side of the Liebert NXL UPS



## 2.0 UPS ELECTRICAL INSTALLATION

This chapter provides guidelines for qualified installers who must have knowledge of local wiring practices pertaining to the equipment to be installed.

### **WARNING**

Risk of electrical shock. Can cause injury or death.

The UPS contains high DC as well as AC voltages. Check for voltage with both AC and DC voltmeters before working within the UPS.

Only properly trained and qualified personnel wearing appropriate safety headgear, gloves, shoes and glasses should be involved in installing the UPS or preparing the UPS for installation.

### 2.1 EXTERNAL PROTECTIVE DEVICES

For safety, it is necessary to install circuit breakers in the input AC supply and external battery system. Given that every installation has its own characteristics, this section provides guidelines for qualified installation personnel with knowledge of operating practices, regulatory standards and the equipment to be installed.

External overcurrent protection must be provided. See **Table 13 - Liebert NXL UPS specifications** for overload capacity.

### 2.2 POWER CABLES

The UPS requires both power and control cabling. All control cables, whether shielded or not, should be run separately from the power cables in metal conduits or metal ducts that are electrically bonded to the metalwork of the cabinets to which they are connected.

The cable design must comply with the voltages and currents in **Tables 14** through **17**, follow local wiring practices and take into consideration the environmental conditions (temperature and physical support media), room temperature and conditions of installation of the cable and system's overload capacity (see **5.0 - Specifications**).

### **WARNING**

Risk of electrical shock. Can cause injury or death.

Before cabling the UPS, ensure that you are aware of the location and operation of the external isolators that connect the UPS input/bypass supply to the power distribution panel.

Check that these supplies are electrically isolated, and post any necessary warning signs to prevent their inadvertent operation.

When sizing battery cables, a maximum volt drop of 2VDC is permissible at the current ratings given in **Table 17**.

The following are guidelines only and are superseded by local regulations and codes of practice where applicable:

- Take special care when determining the size of the neutral cable (grounded conductor), because current circulating on the neutral cable may be greater than nominal current in the case of non-linear loads. Refer to the values in **Table 13**.
- The grounding conductor should be sized according to the fault rating, cable lengths, type of protection, etc. The grounding cable connecting the UPS to the main ground system must follow the most direct route possible.
- Consideration should be given to the use of paralleled smaller cables for heavy currents, as this can ease installation considerably.
- AC and DC cables must be run in conduits according to local codes, national codes and standard best practices. This will prevent creation of excess EMI fields.

## 2.3 SIZING THE INPUT BREAKER FEEDING A LIEBERT NXL UPS

The rectifier nominal input current value (**Table 14**) is based on providing enough power to operate the inverter at full rated load when the input voltage is nominal. The published rectifier maximum input current value is based on the maximum input current limit setting of 125%.

The recommended input breaker ampacity is based on the NEC calculation for a branch circuit with the current limit set at the maximum value. The calculation for a 100% rated breaker is 100% of the nominal current (continuous) plus 100% of the difference between the nominal and the maximum currents (noncontinuous).

The rectifier input current limit can be adjusted from 25% to 125% of the nominal value. This setting is only accessible to a factory-trained service engineer. The effect of changing this setting is similar to that of changing the setting of the trip unit on a solid state circuit breaker. With a lower current limit setting the calculation for the branch circuit will result in a lower value.

The input current limit should not be set less than 105% of the current needed to support the inverter at full load for normal operation. This results in sufficient power to recharge the battery in a reasonable time and to operate over the published input voltage range.

### 2.3.1 Power Cable Connection Procedure

The rectifier input, bypass, output and battery power cables (all require lug-type terminations) are connected to busbars in the I/O sections (refer to **4.0 - Installation Drawings**).

Equipment Ground

The equipment ground busbar is in the I/O sections as shown in (refer to **4.0 - Installation Drawings**). The grounding conductor must be connected to the ground busbar and bonded to each cabinet in the system.

All cabinets and cabling should be grounded in accordance with local regulations.



#### NOTE

*Proper grounding reduces problems in systems caused by electromagnetic interference.*



## WARNING

Failure to follow adequate grounding procedures can result in electric shock hazard to personnel, or the risk of fire, should a ground fault occur.

All operations described in this section must be performed by properly trained and qualified electricians or technical personnel. If any difficulties are encountered, contact Vertiv. See the back page of this manual for contact information.

The grounding and neutral bonding arrangement must be in accordance with local and national codes of practice.

Once the equipment has been positioned and secured, connect the power cables as described below (refer to the appropriate cable connection drawing in **4.0 - Installation Drawings**):

1. Verify that the UPS equipment is isolated from its external power source and all the UPS power isolators are open. Check that these supplies are electrically isolated and post any necessary warning signs to prevent their inadvertent operation.
2. Open exterior and interior panels on the front of the I/O sections.
3. Connect the ground and any necessary main bonding jumper to the equipment ground busbar located in the I/O sections.
4. Make power connections and tighten the connections to the proper torque.  
Ensure correct phase rotation.



## WARNING

Risk of electrical shock. Can cause injury or death.

If the load equipment will not be ready to accept power on the arrival of the commissioning engineer, ensure that the system output cables are safely isolated at their termination.

# ⚠ WARNING

Risk of electrical shock. Can cause injury or death.

When connecting the cables between the battery extremities to the circuit breaker, always connect the circuit breaker end of the cable first.

- For control connection details, see **2.4 - Control Cable and Communication**.

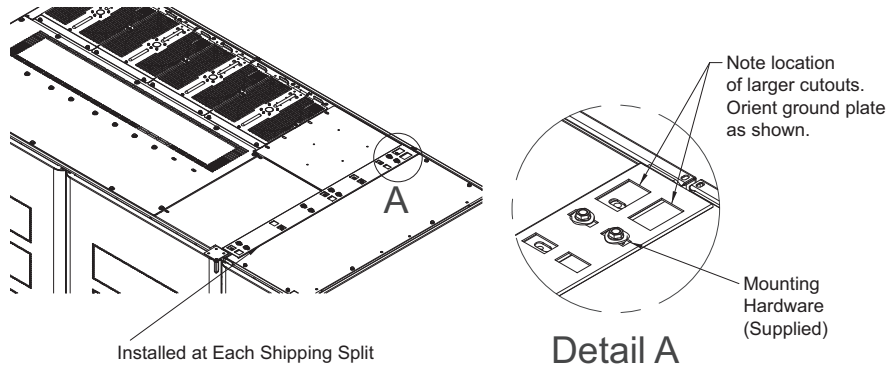


## NOTE

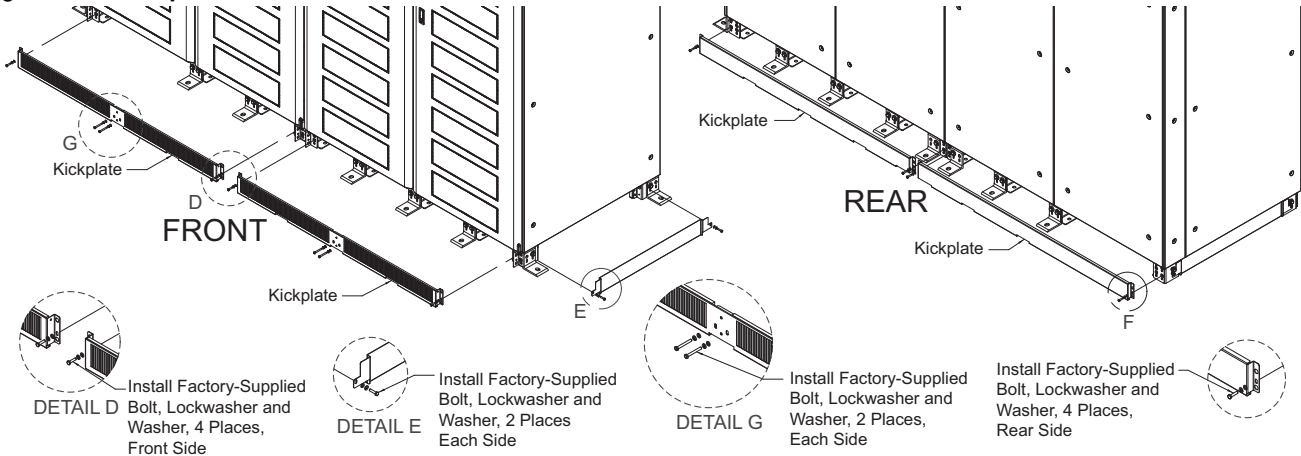
*If fault bracing brackets were removed during installation, they MUST be replaced.*

- Close and secure the interior and exterior doors.
- Attach the cabinet EMI plates to the top of the UPS at each shipping split (625kVA or 750kVA only). See **Figure 2**.
- Attach the kick plates and filters to the bottom of the unit. See **Figure 3**.

**Figure 2 Cabinet EMI plates - 625kVA and 750kVA only**



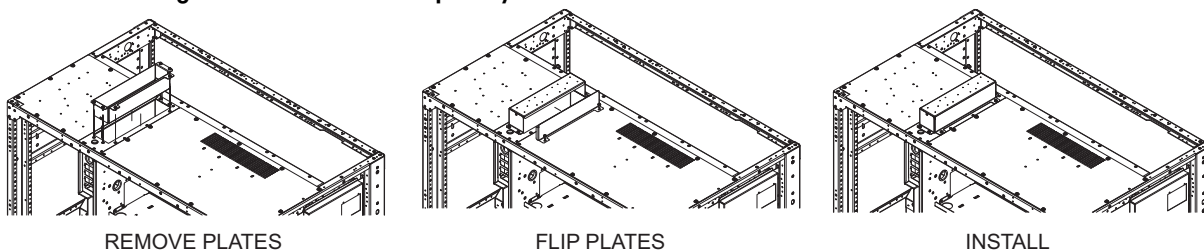
**Figure 3 Kick plate and filter locations**



## NOTE

*Kick plates must be installed. If the unit is to be installed in a position that does not permit access to rear kick plates, then the kick plates must be installed before the unit is placed in its final position.*

**Figure 4 Low-voltage cable installation—top entry**

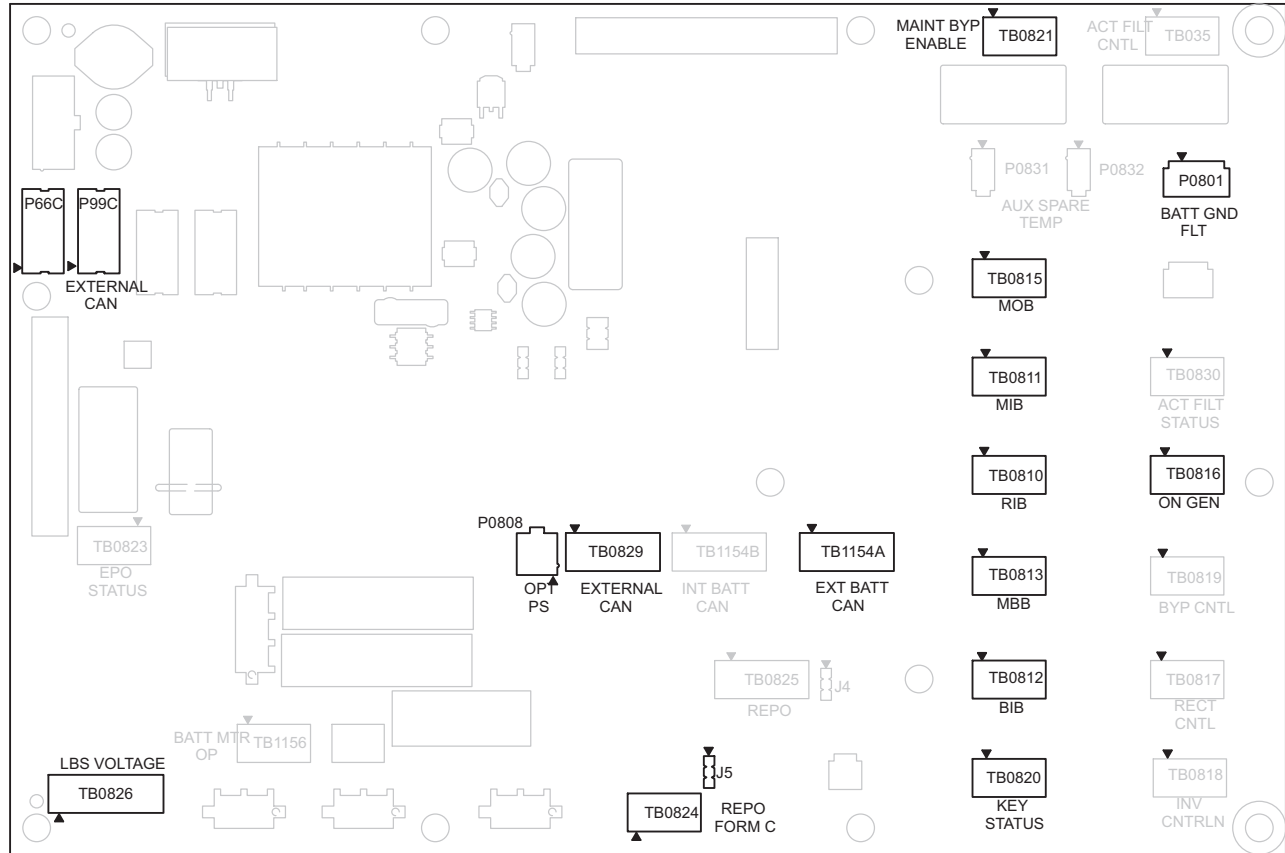


Low-voltage cables can be install through the top of each unit. The entry conduit landing plate is shipped inverted. To install, remove conduit plate, flip and reinstall. Removal of side plate is for access to pull wires.

## 2.4 CONTROL CABLE AND COMMUNICATION

Based on your site's specific needs, the UPS may require auxiliary connections to manage the battery system (external battery circuit breaker), communicate with a personal computer or provide alarm signaling to external devices, or for Remote Emergency Power Off (REPO). The External Interface Board, arranged for this purpose, is next to the option box in the Rectifier section (refer to **4.0 - Installation Drawings**). The contacts are rated for 250VAC @ 2A.

**Figure 5 External Interface Board connections layout**



### 2.4.1 Dry Contacts



**NOTE**

*If connection to more than one module is required, use a separate, isolated contact for each module.*

**Table 1 UPS input dry contacts**

Item	Terminal Block	Pin	Connects to (Description of External Item)	Wire Size/ Max Length
Remote EPO Input Form C	TB0824	1	REPO Switch, normally open contact	14AWG/ 500ft. (150m)
		2	REPO Switch, common contact	
		3	REPO Switch, normally closed contact, set jumper J5: 1-2 to enable, 2-3 to disable	
On Generator Input Form C	TB0816	1	On Generator switch, closed = On Generator	
		2	On Generator switch, common	
		3	On Generator switch, closed = Not On Generator	



**Table 2 UPS control contacts with battery cabinet or module battery disconnect**

Item	Terminal Block	Pin	Connects to (Description of External Item)	Wire Size/ Max Length
CAN Bus and 24V Power Supply	TB1154A	1	Battery Interface Board TB1154-1	18 AWG 1000ft. (300m)
		2	Battery Interface Board TB1154-2	
		3	Battery Interface Board TB1154-3	
		4	Battery Interface Board TB1154-4	

**Table 3 UPS control contacts with global maintenance bypass**

Item	Terminal Block	Pin	Connects to (Description of External Item)	Wire Size/ Max Length
Maintenance Isolation Breaker (MIB) Form C <sup>1</sup>	TB0811	1	CB aux. contact, closed = CB is closed	14AWG/500ft. (150m)
		2	CB aux. contact, common	
		3	CB aux. contact, closed = CB is open	
Maintenance Bypass Breaker (MBB) Form C <sup>1</sup>	TB0813	1	CB aux. contact, closed = CB is closed	14AWG/500ft. (150m)
		2	CB aux. contact, common	
		3	CB aux. contact, closed = CB is open	
Maintenance Bypass Enable Form C <sup>1</sup>	TB0821	1	Maintenance Bypass Cabinet, closed = load not on inverter	14AWG/500ft. (150m)
		2	Maintenance Bypass Cabinet, common	
		3	Maintenance Bypass Cabinet, closed = load on inverter	
Remote EPO Input <sup>1</sup>	TB0825	1	REPO Switch, normally open contact	14AWG/500ft. (150m)
		2	REPO Switch, common contact	
Key Status Input Form C <sup>1,3</sup>	TB0820	1	Key status switch, closed = key removed	14AWG/500ft. (150m)
		2	Key status switch, common	
		3	Key status switch, closed = key inserted	
Module Output Breaker (MOB) Form C <sup>2</sup>	TB0815	1	CB aux. contact, closed = CB is closed	14AWG/500ft. (150m)
		2	CB aux. contact, common	
		3	CB aux. contact, closed = CB is open	

1. For 1+N systems with a maintenance Bypass, these auxiliary contacts must be run to each module from an isolated source.
2. For 1+N systems, these breaker Aux contacts go to the UPS that they are associated with.
3. Key Status Input can be either Form-C, N.O. or N.C. contact

**Table 4 UPS control contacts to remote status panel**

Item	Terminal Block	Pin	Connects to (Description of External Item)	Wire Size/ Max Length
CAN Bus and 24V Power Supply	TB0829	1	Remote Status Panel TB-2	18AWG/1000ft. (300m)
		2	Remote Status Panel TB-1	
		3	Remote Status Panel TB-3	
		4	Remote Status Panel TB-4	

## 2.4.2 Multi-Module Communication

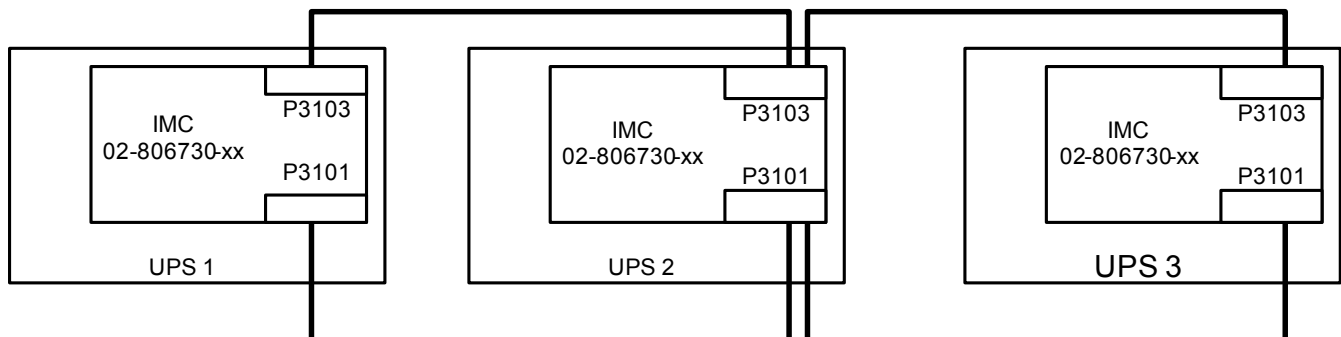
Paralleling cables that connect the module to the system are connected to terminals P3101 and P3103 on the Inter-Module Communication (IMC) board (refer to **4.0 - Installation Drawings**).

**Table 5 Parallel from UPS module Inter-Module Communication Board to other Inter-Module Communication Board in system**

Terminal Designation		Signal Name	Wire Size/ Max Length
From	To		
<b>Primary Connections</b>			
P3101-1	P3101-1	Share CAN +24V	1000ft. (300m)
P3101-2	P3101-2	Share CAN common	
P3101-3	P3101-3	System CAN +24V	
P3101-4	P3101-4	System CAN common	
P3101-5	P3101-5	SER synch CAN+24V	
P3101-6	P3101-6	SER synch CAN common	
P3101-7	P3101-7	Ground - Drain Wire	
P3101-14	P3101-14	Ground	
P3101-8	P3101-8	PWM synch CAN +24V	
P3101-9	P3101-9	PWM synch CAN common	
P3101-10	P3101-10	MMS synch CAN +24V	
P3101-11	P3101-11	MMS synch CAN common	
<b>Redundant Connections</b>			
P3103-1	P3103-1	Redundant share CAN +24V	1000ft. (300m)
P3103-2	P3103-2	Redundant share CAN common	
P3103-3	P3103-3	Redundant system CAN +24V	
P3103-4	P3103-4	Redundant system CAN common	
P3103-5	P3103-5	Redundant SER synch CAN +24V	
P3103-6	P3103-6	Redundant SER synch CAN common	
P3103-7	P3103-7	Ground - Drain Wire	
P3103-14	P3103-14	Ground	
P3103-8	P3103-8	Redundant PWM synch CAN +24V	
P3103-9	P3103-9	Redundant PWM synch CAN common	
P3103-10	P3103-10	Redundant MMS synch CAN +24V	
P3103-11	P3103-11	Redundant MMS synch CAN common	

1. Belden 810x or Belden 89901 cables are the only approved cables.
2. Belden 89901 cable can be used for underground installations.
3. If using multiple parallel cables for each run, all cables must be run in the same conduit.
4. Each cable group should be run in a separate grounded conduit to ensure redundancy.
5. The maximum lengths must include all the parallel cables from the first module to the last module. The primary and redundant cable lengths can be counted separately.
6. The ground pins on the Inter-Module Communication Board (Pins 7 and 14) are connected together on the board. If using cable with only one (1) drain wire, then connect the ground (drain wire) to Pin 7.
7. Care must be taken so drain wire does not touch any other component in module.
8. Attach control wires to side of control door where Inter-Module Board (IMC) is attached. Do not run wires across IMC board.

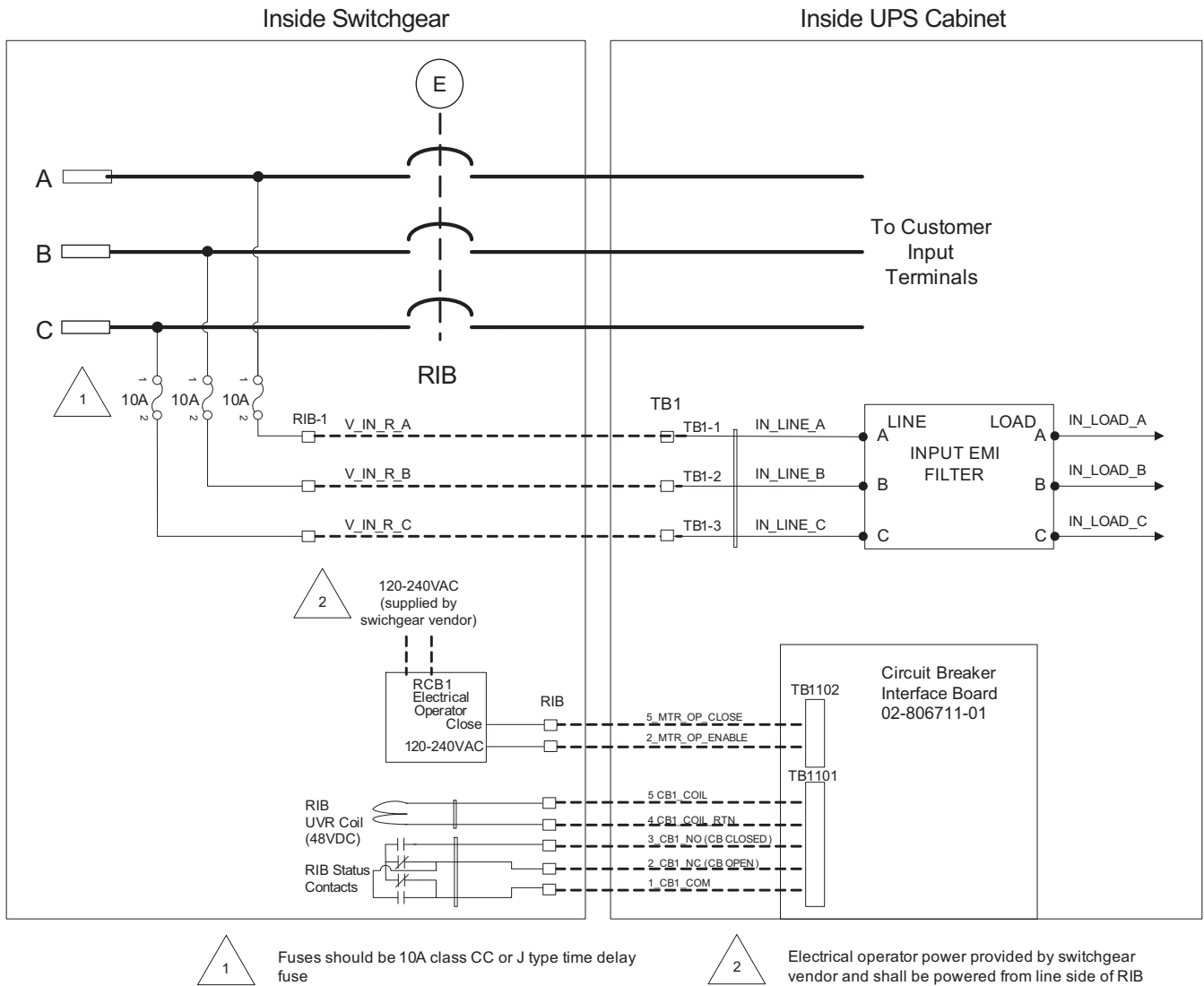
**Figure 6 Inter-Module Communication Board wiring diagram—Multi-modules**



### 2.4.3 Remote Input Breaker (RIB)

For systems that use Remote Input Breakers (RIB), the controls for the Aux contacts, UVR, Motor Operator (optional) and voltage sense will go between the Remote breaker and the UPS Input I/O section. See **Figure 7**.

**Figure 7 Remote Input Breaker diagram**



RIB must be Listed UL 489 (Molded Case Circuit Breaker) or UL 1066 (Low Voltage AC Power Circuit Breaker) that are required to be used in UL-listed switchgear or switchboards. The circuit breaker must have a short-time rating not exceeding 480V at 150K Amperes, for 5 cycles.

See **Table 14** for required current ratings.

**Table 6 RIB UV coil, aux. contacts from UPS RIB CB interface board to remote CB1**

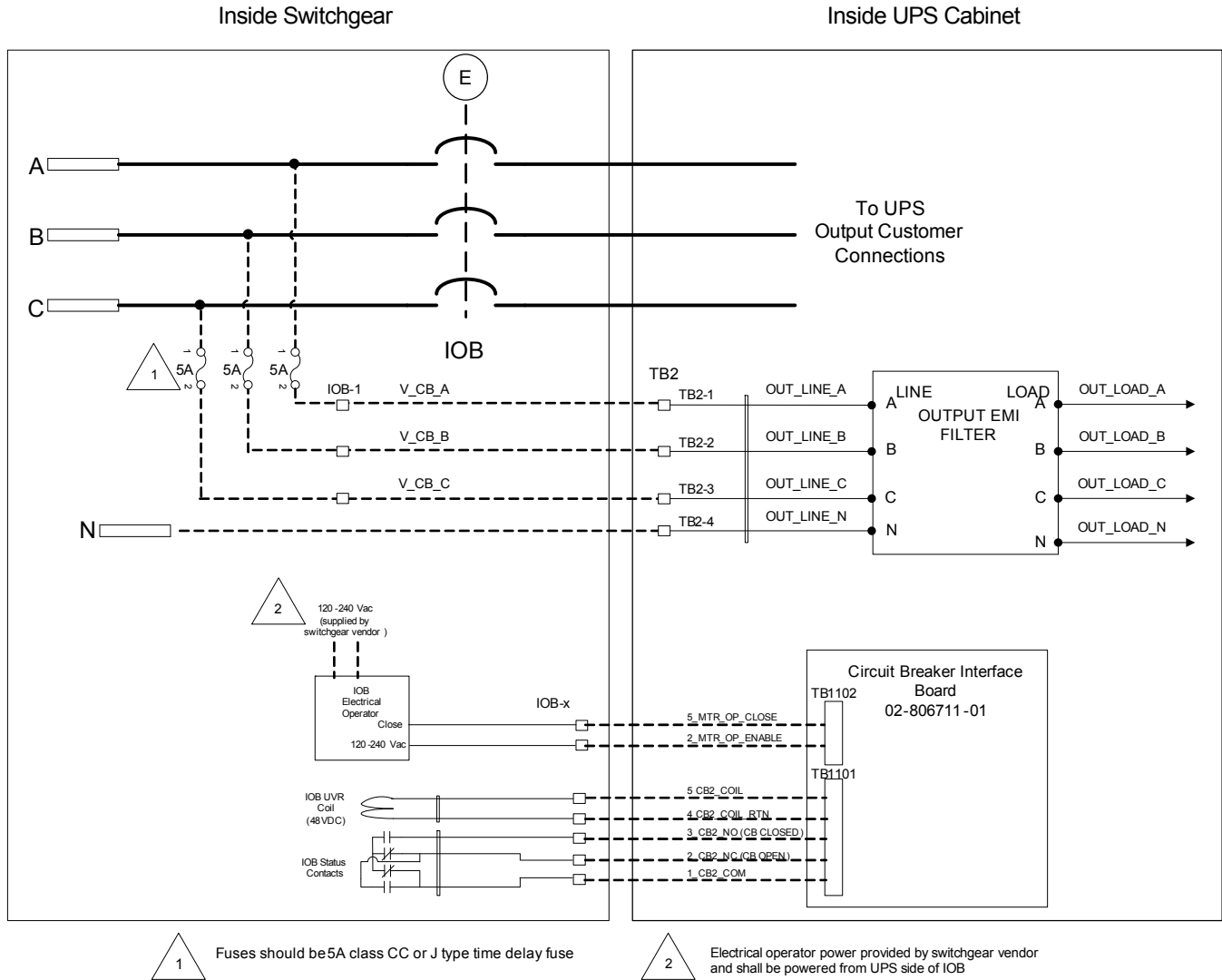
Terminal Designation		Signal Name	Wire Size/ Max Length
From	To		
Remote Breaker Contacts	TB1101-1	RIB aux. common	#14AWG/ 500ft. (150m)
	TB1101-2	RIB aux. N.C. (closed = CB is open)	
	TB1101-3	RIB aux. N.O. (closed = CB is closed)	
	TB1101-4	RIB trip coil (-)	
	TB1101-5	RIB trip coil (+)	
<b>Remote RIB motor operator control contacts from remote breaker to UPS RIB CB interface board (optional)</b>			
Remote Breaker Motor Operator Contacts	TB1102-2	AC line	#14AWG/ 500ft. (150m)
	TB1102-5	Motor operator close	
<b>Remote RIB voltage sense from remote breaker to UPS</b>			
Remote Breaker Voltage Sense	TB1-1	Voltage sense PH A	#14AWG/ 500ft. (150m)
	TB1-2	Voltage sense PH B	
	TB1-3	Voltage sense PH C	

#### 2.4.4 Inverter Output Breaker (IOB)

For systems that use Inverter Output Breakers (IOB), the controls for the Aux contacts, UVR, Motor Operator (optional) and voltage sense will go between the Remote breaker and the UPS Output I/O section. See **Figure 8**.

IOB must be Listed UL 489 (Molded Case Circuit Breaker) or UL 1066 (Low Voltage AC Power Circuit Breaker) that are required to be used in UL-listed switchgear or switchboards. The circuit breaker must have a short-time rating not exceeding 480 Volts at 150K Amperes, for 5 cycles.

Figure 8 Remote Output Breaker diagram



See Table 15 for required current ratings.

Table 7 Remote IOB contacts from remote breaker to UPS IOB CB interface board

Terminal Designation		Signal Name	Wire Size/ Max Length
From	To		
Remote Breaker Contacts	TB1101-1	IOB aux. common	#14AWG/ 500ft. (300m)
	TB1101-2	IOB aux. N.C. (closed = CB is open)	
	TB1101-3	IOB aux. N.O. (closed = CB is closed)	
	TB1101-4	IOB trip coil (-)	
	TB1101-5	IOB trip coil (+)	
<b>Remote IOB contacts from remote breaker to UPS IOB CB interface board</b>			
Remote Breaker Motor Operator Contacts	TB1102-2	AC line	#14AWG/ 500ft. (300m)
	TB1102-5	Motor operator close	
<b>Remote IOB contacts from remote breaker to UPS IOB CB interface board</b>			
Remote Breaker Voltage Sense	TB1-1	Voltage sense PH A	#14AWG/ 500ft. (300m)
	TB1-2	Voltage sense PH B	
	TB1-3	Voltage sense PH C	

## 2.5 DIGITAL LBS

The Load Bus Sync interface enables independent UPS units to remain in sync when operating on battery or when supplied by unsynchronized input sources.

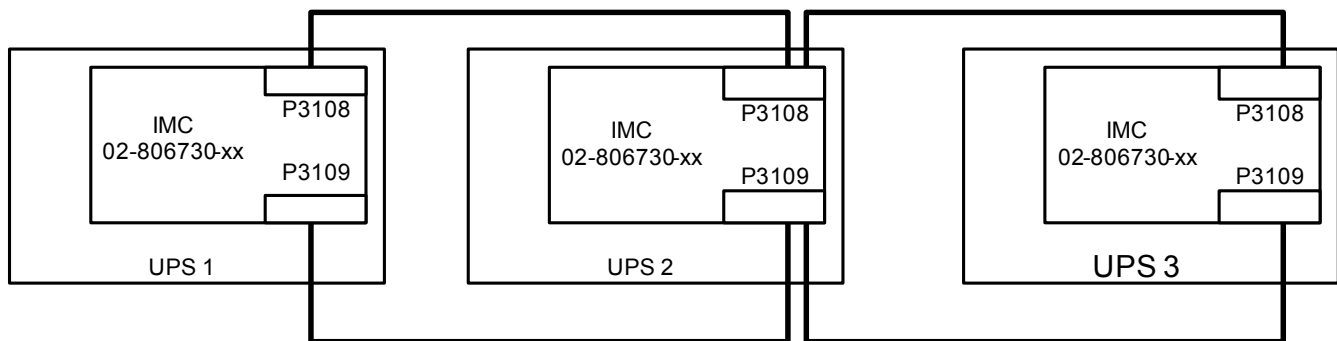
Digital LBS cables that connect the module to the system are connected to terminals P3108 and P3109 on the Inter-Module Communication (IMC) board. See **Figure 9**.

**Table 8 Wire size, length for digital LBS connection of UPS Inter-Module Communication Boards**

Terminal Designation		Signal Name	Wire Size/ Max Length
From	To		
<b>Digital LBS from UPS Inter-Module Communication Board to other UPS Inter-Module Communication Board</b>			
P3108-1	P3108-1	LBS SYNCH CANH	3000ft (900m)
P3108-2	P3108-2	LBS SYNCH CANL	
P3108-3	P3108-3	GROUND - DRAIN WIRE	
<b>Redundant Digital LBS from UPS Inter-Module Communication Board to Other UPS Inter-Module Communication Board</b>			
P3109-1	P3109-1	REDUNDANT LBS SYNCH CANH	3000ft (900m)
P3109-2	P3109-2	REDUNDANT LBS SYNCH CANL	
P3109-3	P3109-3	GROUND - DRAIN WIRE	

1. Belden 810x or Belden 89901 cables are the only approved cables
2. Each cable group should be run in a separate, grounded conduit to ensure redundancy.
3. The maximum lengths must include all the LBS cables from the first module to the last module.
4. The primary and redundant cable lengths can be counted separately.
5. Belden 89901 cable can be used for underground installations.
6. Attach the control wire to the side of control door where the Inter-Module Board (IMC) is attached. Do not run the wire across IMC board.

**Figure 9 Inter-Module Communication Board wiring diagram—Digital LBS**



## 2.6 CONFIGURING NEUTRAL AND GROUND CONNECTIONS

Improper grounding is the largest single cause of UPS installation and startup problems. Grounding techniques vary significantly from site to site, depending on several factors.

Proper grounding should be based on NEC Section 250, but safe and proper equipment operation requires further enhancements. The following pages detail recommendations for grounding various system configurations to ensure optimal UPS system performance.



### NOTE

*Some UPS modules are equipped with input isolation transformers. However, these transformers have no effect upon any system grounding considerations. These modules will be grounded exactly as shown in **Figures 10 through 13**.*



### CAUTION

The UPS ground lug must be solidly connected to the service entrance ground by an appropriately sized wire conductor per NEC Article 250. Each conduit or raceway containing phase conductors must also contain a ground wire, both for UPS input and output, which are solidly connected to the ground terminal at each termination point. Conduit-based grounding systems tend to degrade over time. Therefore, using conduit as a grounding conductor for UPS applications may degrade UPS performance and cause improper UPS operation.

#### 2.6.1 Four-Wire Input connections

The UPS module bypass input is connected to a solidly grounded source. In this configuration, the UPS module is not considered a separately derived source. The UPS module output neutral is solidly connected to the bypass source neutral, which is bonded to the grounding conductor at the source equipment.

#### 2.6.2 Three-Wire Input connections

This configuration must NOT be used when single-phase loads are directly connected to the UPS. The UPS output is considered a separately derived source. The UPS module neutral is bonded to the UPS ground and connected to a local grounding electrode in accordance with NEC 250-26. Please note that whenever the UPS module transfers to or from bypass, two AC sources (UPS output and bypass) are briefly connected together and circulating current must flow. In this configuration, the current flows through the ground path, possibly tripping ground fault interrupters (GFIs) and distorting the output voltage waveform. Proper adjustment of ground fault interrupters is necessary to avoid unwanted tripping. The time delay should be set to at least 0.2 seconds to prevent tripping when the UPS performs a transfer or retransfer operation.

### NOTICE

Risk of improperly set ground fault interrupters. Can cause equipment damage.

Failure to set the ground fault interrupters properly could cause loss of power to the critical load.

#### 2.6.3 Preferred Grounding Configuration, Battery Systems

Open-rack battery systems, depending on local code requirements and customer preference, are normally:

- Floating (ungrounded)
- OR
- Center-tapped and floating

Battery cabinet systems must be connected as floating (ungrounded) systems.

Center-tapped or grounded battery systems are not possible with battery cabinet systems.

Whether the battery system is open-rack or cabinet, the metal rack parts or cabinet must be grounded to the UPS module ground bus.

### 2.6.4 Multi-Module Systems

For both N+1 and 1+N systems, the neutrals of all UPS modules in the system must be connected together inside the switchgear or parallel cabinet. The neutral conductors must be rated for 20% of phase conductor current minimum. Site and load conditions will determine if larger neutrals are required.

For Multi-Module systems using a 3-wire bypass, the Neutral-Ground bond must be made at the common neutral connection point in the switchgear or parallel cabinet.

### 2.6.5 High Resistance Ground Systems

The Liebert NXL is compatible with High Resistance Ground Systems. See your local Vertiv representative for details.

## 2.7 GROUNDING DIAGRAMS, SINGLE- AND MULTI-MODULE SYSTEMS

Figure 10 Grounding diagram, three-wire single-module system

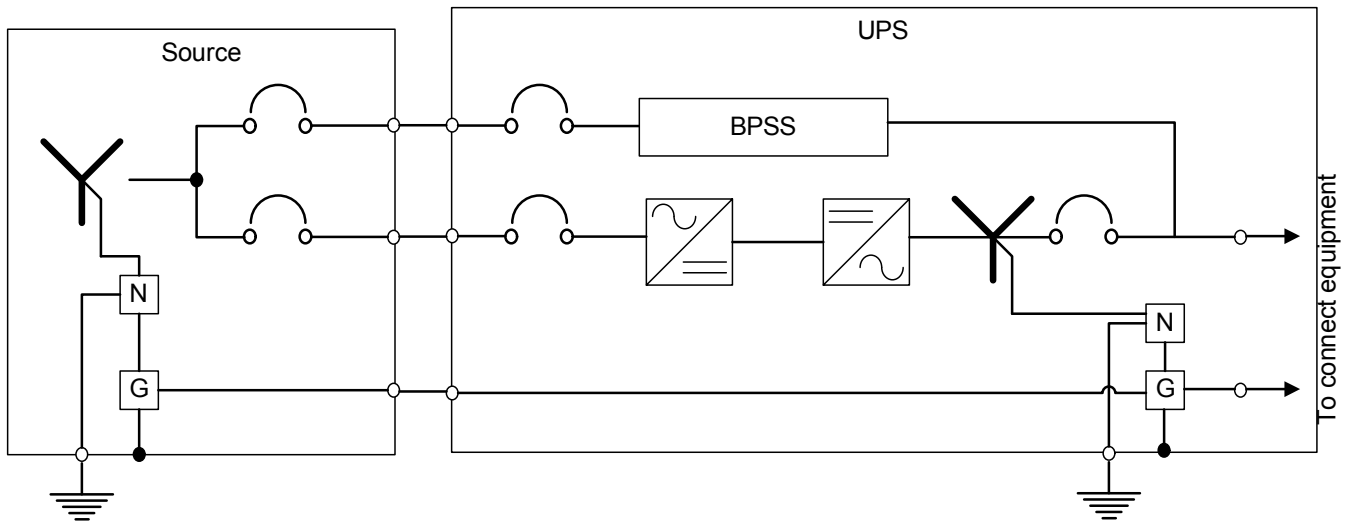


Figure 11 Grounding diagram, four-wire single-module system

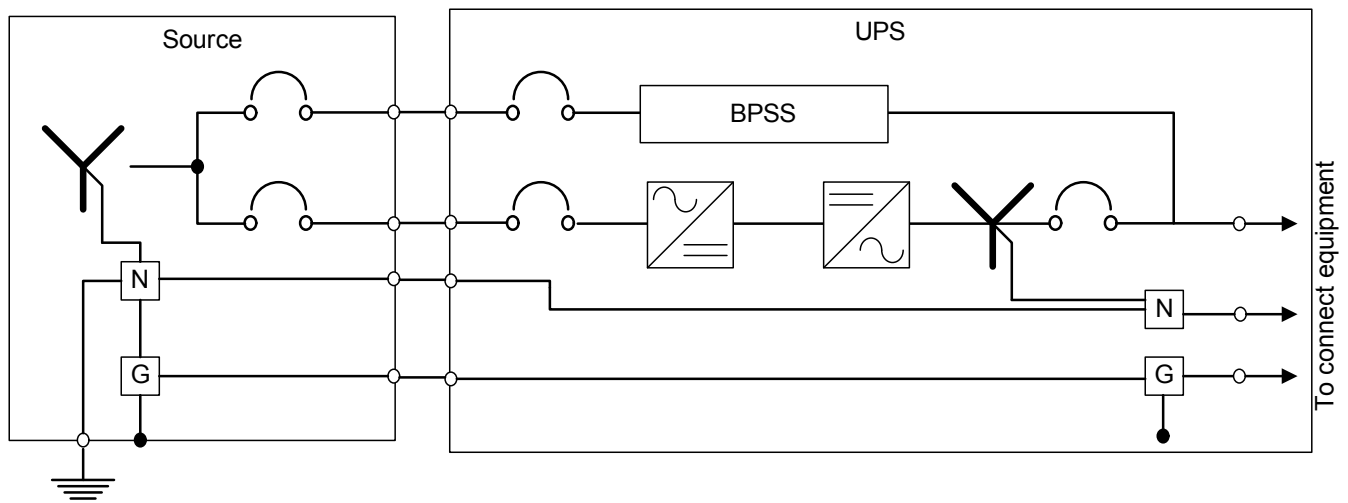




Figure 12 Grounding diagram, three-wire multi-module system

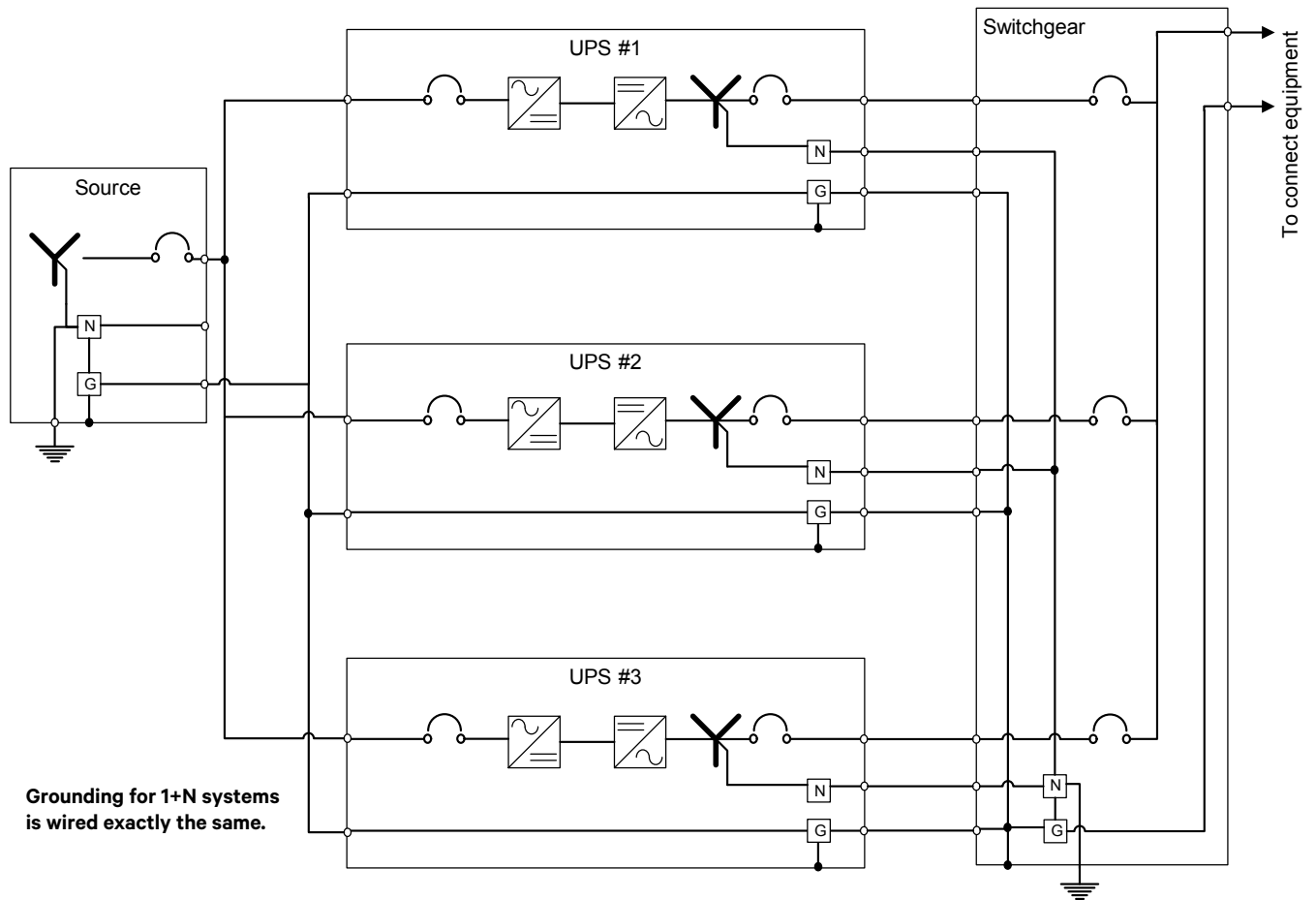
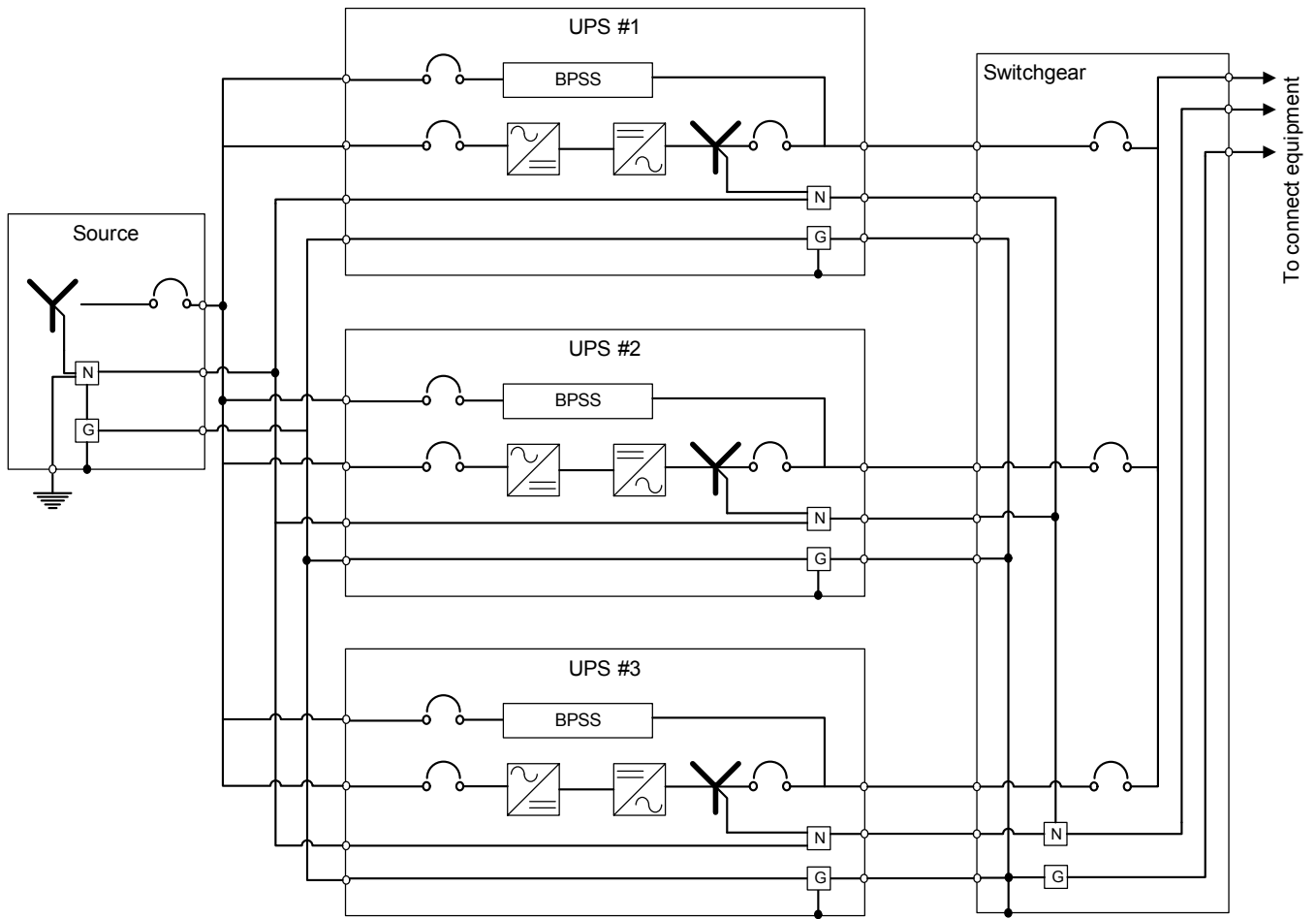


Figure 13 Grounding diagram, four-wire multi-module system



## 3.0 OPTIONAL EQUIPMENT

---

### 3.1 SINGLE-MODULE SYSTEM OPTIONS

#### 3.1.1 Matching Maintenance Bypass Cabinet

A matching Liebert NXL Maintenance Bypass cabinet is available. See Maintenance Bypass Cabinet Installation Manual (SL-24532) for more details.

#### 3.1.2 Battery Temperature Sensor

The optional external battery temperature sensor kit, supplied separately from the battery circuit breaker, contains one probe and one temperature transport board.

#### 3.1.3 Matching Liebert NXL Battery Cabinet

The optional matching Liebert NXL Battery Cabinet can be used to obtain the desired autonomy time. The battery cabinets are designed to be either attached to the UPS or separate from the UPS (for details, see the Liebert NXL Battery Cabinet installation manual, SL-25430, available at Liebert Web site: [www.liebert.com](http://www.liebert.com)).

#### 3.1.4 Matching Module Battery Disconnect—MBD

The optional Module Battery Disconnect (MBD) can be used as a battery disconnect between a battery system and the Liebert NXL UPS (for details, see the Liebert NXL Battery Cabinet installation manual, SL-24530, available at Liebert's Web site: [www.liebert.com](http://www.liebert.com)).

#### 3.1.5 Load Bus Synch

An optional Load Bus Synch (LBS) system can be used to synchronize two Liebert NXL UPS units or a Liebert NXL UPS to a Liebert Series 610™ UPS.

#### 3.1.6 Remote Alarm Status Panel

The remote alarm status panel has LED alarm lights. An audible alarm sounds upon any alarm condition. The surface- or flush-mounted NEMA 1 enclosed panel indicates: Load on UPS, Load on Bypass, Battery Discharging, Low Battery Warning, Overload Warning, Ambient Overtemp Warning, UPS Alarm Condition, New Alarm Condition (For a Second UPS Alarm Condition).

### 3.2 COMMUNICATION AND MONITORING

- Liebert IntelliSlot™ Web Card - SNMP/HTTP Network Interface Card
- Liebert IntelliSlot 485 Web Card - Modbus, J-bus, IGM Net
- Remote Monitoring Services IntelliSlot Card
- RS485/422 Protocol Converter IntelliSlot Card
- Alber Battery monitoring system
- Programmable Relay Board
- Input Contact Isolator Board

#### 3.2.1 Alber Monitoring System

The matching Liebert NXL Battery Cabinet allows installing an optional Alber Battery monitoring system in the cabinet. The Alber Battery Monitoring by Liebert continuously checks all critical battery parameters, such as cell voltage, overall string voltage, current and temperature. Automatic periodic tests of internal resistance of each battery will verify the battery's operating integrity. Additional capabilities include automatic internal DC resistance tests and trend analysis, providing the ability to analyze performance and aid in troubleshooting.

### 3.2.2 Programmable Relay Board

The Programmable Relay Board (PRB) provides a means to trigger an external device when an event occurs in the Liebert NXL. Each PRB has eight channels. Each channel has Form-C dry contacts rated at 1A @ 30VDC or 125VAC @ 0.45A.

Any alarm/event can be programmed to any channel or channels. Up to four (4) events can be programmed to a relay. If multiple events are grouped to one relay, group the events logically to simplify troubleshooting when an event is triggered. The same alarm/event can be programmed to more than one channel. Up to two Programmable Relay Boards can be installed in the Liebert NXL for a total of 16 channels. Programming is performed through the HMI touchscreen display.



**NOTE**

Up to two (2) PRB's can be installed in the Liebert NXL.

**Figure 14 Control wiring, Programmable Relay Board**



- Customer control wiring connection points are terminals 1 through 15. (Pin 16 not used on J71, J72, and J73.)
- Programmable Relay Board option includes eight signal channels with two Form-C dry contacts per channel (see **Table 12**).
- All control wiring (by others) must be run separate from power wiring. Control wiring runs should not be combined in the same conduit.
- Contact ratings: 1A @ 30VDC or 125VAC @ 0.45A
- Maximum cable length 500 ft. (152m) with #16AWG and flexible stranded cable.
- All wiring must be in accordance with national and local electrical codes.

**Table 9 Programmable Relay Board pinout**

Terminal Block	Channel	Pin No.	Common	Normally Closed	Normally Open	
J71	CH1	A	1-3	1	2	3
		B	4-6	4	5	6
	CH2	A	7-9	7	8	9
		B	10-12	10	11	12
	CH3	A	13-15	13	14	15
		B	1-3	1	2	3
J72	CH4	A	4-6	4	5	6
		B	7-9	7	8	9
	CH5	A	10-12	10	11	12
		B	13-15	13	14	15
	CH6	A	1-3	1	2	3
		B	4-6	4	5	6
TB3	CH7	A	7-9	7	8	9
		B	10-12	10	11	12
	CH8	A	13-15	13	14	15
		B	1-3	1	2	3
	J74					

Note: Pin 16 not used on J71, J72, and J73.

### Configuring the Programmable Relay Board Settings

1. Press Internal Option Settings from the Config menu.
2. Press which Programmable Relay Board will be configured. The Programmable Relay Board dialog box is displayed.
3. Press the Relay channel
4. Press up to four (4) events. Selected events will show up under Relay 1 Assignment.

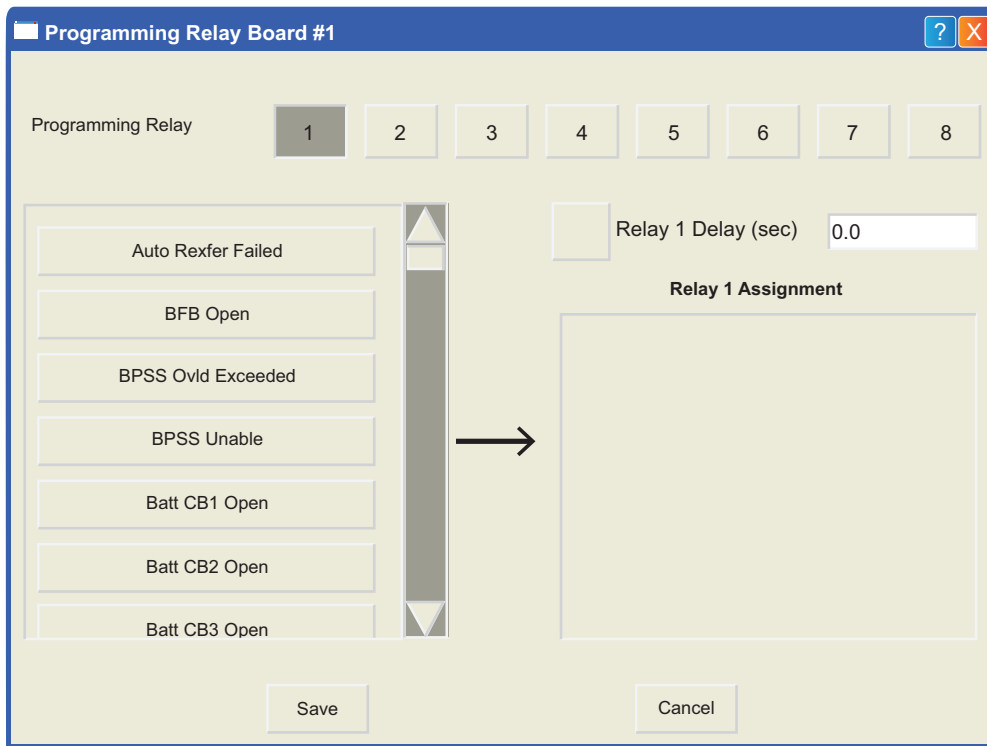


**NOTE**

*To deselect an event, click on the event.*

5. Repeat **Steps 3** and **4** for each relay.
6. Press **SAVE** to keep the settings.

**Figure 15 Programmable relay board dialog box**



- Assignment—0 to 4 event (default: 0)
- Delay, sec—0 to 99.9 (default: 0)

### 3.2.3 Input Contact Isolator Board

The Input Contact Isolator Board (ICI) provides a Liebert NXL module interface for up to eight external user alarm or message inputs to be routed through the NXL’s alarm network. The eight contacts are normally open dry contacts. When a contact closes, an event is triggered.



**NOTE**

*Up to two (2) ICI's can be installed in a Liebert NXL.*

The Input Contact Isolator options are configured through the Input Contact Isolator dialog box, which is accessed from the Internal Option Settings under Config dialog box on the HMI touchscreen display. The Input Contact Isolator dialog box contains eight choices to match the eight channel input board. You can label each button to identify the event associated with the contact. When the dialog box is accessed, each button flashes to display the Input Contact Isolator number and the user entered label. This label also appears in the Display Panel when an event related to an Input Isolator Connector is triggered.

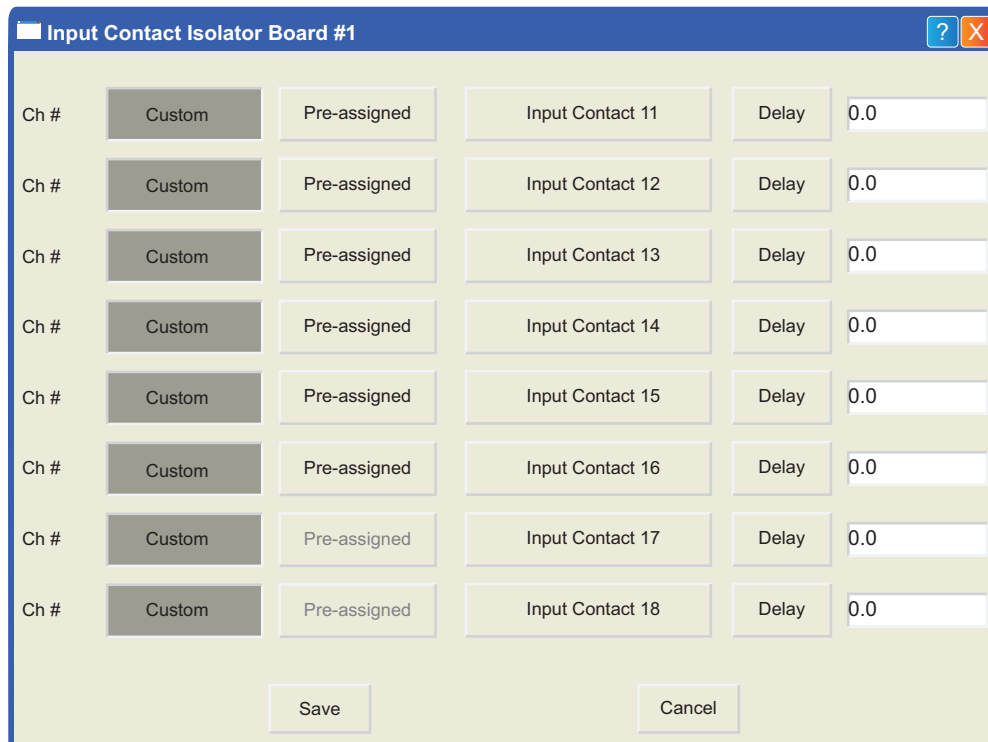
The Input Contact Isolator dialog box allows you to:

- Label the input contact assignments for your setup.
- Set the delay for an external event triggering an alarm.
- Review the isolator contact assignments, once the labels are entered.

The delay allows setting the number of seconds that a condition must exist before it will trigger an alarm. To configure the Input Contact Isolator relays:

1. Press Internal Option Settings from the Config menu.
2. Press which Input Contact Isolator is to be configured. The Input Contact Isolator dialog box is displayed.

**Figure 16 Input contact isolator dialog box**



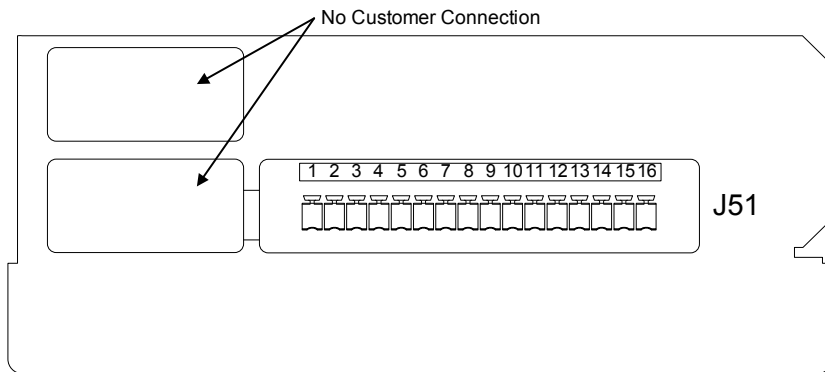
- Assignment—Custom, Pre-assigned (default: “Input Contact” XY)
- Delay, sec—0 to 99.9 (default: 0)
- Message—Custom: 0-19 characters

3. To assign labels for each channel:
  - a. Press Pre-assigned for default labels on Channels 1-6 (See **Table 10**)
  - b. For Custom labels
    1. Press Custom to unique labels.
    2. Click on Input Contact XX button. A keyboard is displayed to allow naming alarms.
    3. Enter the name of the alarm set for that input. For example, a fan problem could be indicated by naming the button FAN.
    4. Press OK on the keyboard to keep your label.
4. Press DELAY.
  - a. A keypad is displayed prompting you for a delay time, in seconds, for a condition to exist before the alarm is triggered.
  - b. Enter the delay value. The range for the values are from 0 (zero) to 99.9 seconds.
  - c. Press OK on the keypad to keep your setting. The value you entered is displayed in the field adjacent to the corresponding input contact.
5. Repeat **Steps 3** and **4** for each input contact.
6. Press SAVE after you have configured all input contacts.  
Be sure to press Save even if you have accessed this dialog only to change a setting.
7. This information is not saved if control power is removed.

**Table 10 Input Contact Isolator Board pre-assigned values**

Channel Number	ICI #1 Pre-Assigned Label	ICI #2 Pre-Assigned Label
1	Reduced Rect ILimit	Stop Battery Charge
2	Reduced Batt ILimit	Stop Battery Charge
3	Stop Battery Charge	Stop Battery Charge
4	Inhibit Rect Restr	Stop Battery Charge
5	Inhibit Byp Restr	Stop Battery Charge
6	Inhibit Inv Restr	Stop Battery Charge
7	Input Trap Filter Disconnect	Inhibit IP Standby
8	Suspend ECO Mode	—

**Figure 17 Optional Input Contact Isolator Board**



1. Customer control wiring connection points are terminals 1 through 16 (see **Table 11**).
2. Customer provided normally open dry contacts for user alarm messages.
3. All control wiring (by others) must be run separate from power wiring. Control wiring runs should not be combined in the same conduit.
4. Signal voltage: 100mA @ 12VDC.
5. Maximum cable length 500 ft. (152m) with #16AWG and flexible stranded cable.
6. All wiring must be in accordance with national and local electrical codes.

**Table 11 Input Contact Isolator Board control wiring connections**

Input Contact	Pin No.
1	1
	2
2	3
	4
3	5
	6
4	7
	8
5	9
	10
6	11
	12
7	13
	14
8	15
	16

## 4.0 INSTALLATION DRAWINGS

Figure 18 Main components, 500kVA Liebert NXL SMS and 1+N multi-module unit with static bypass

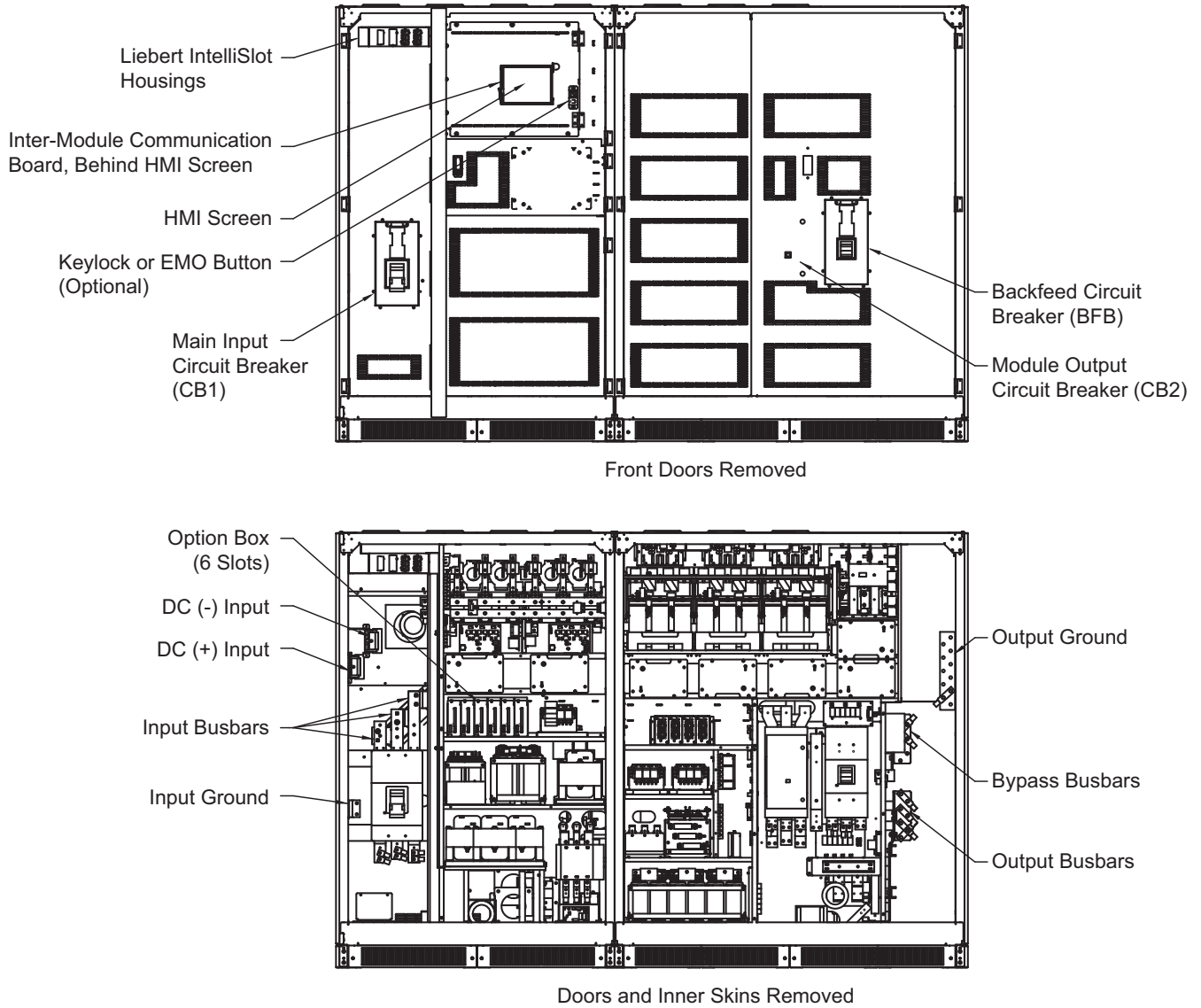
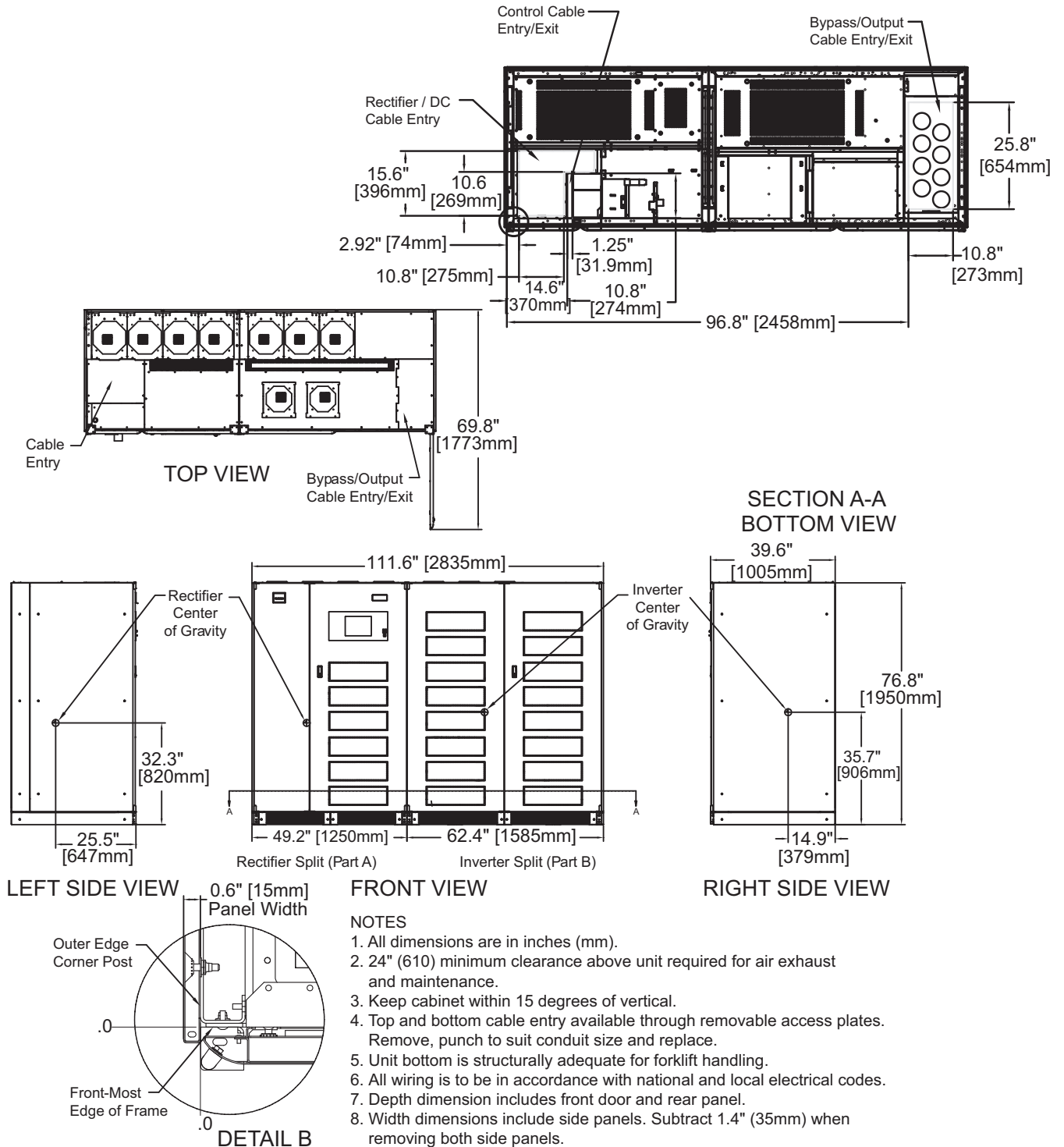
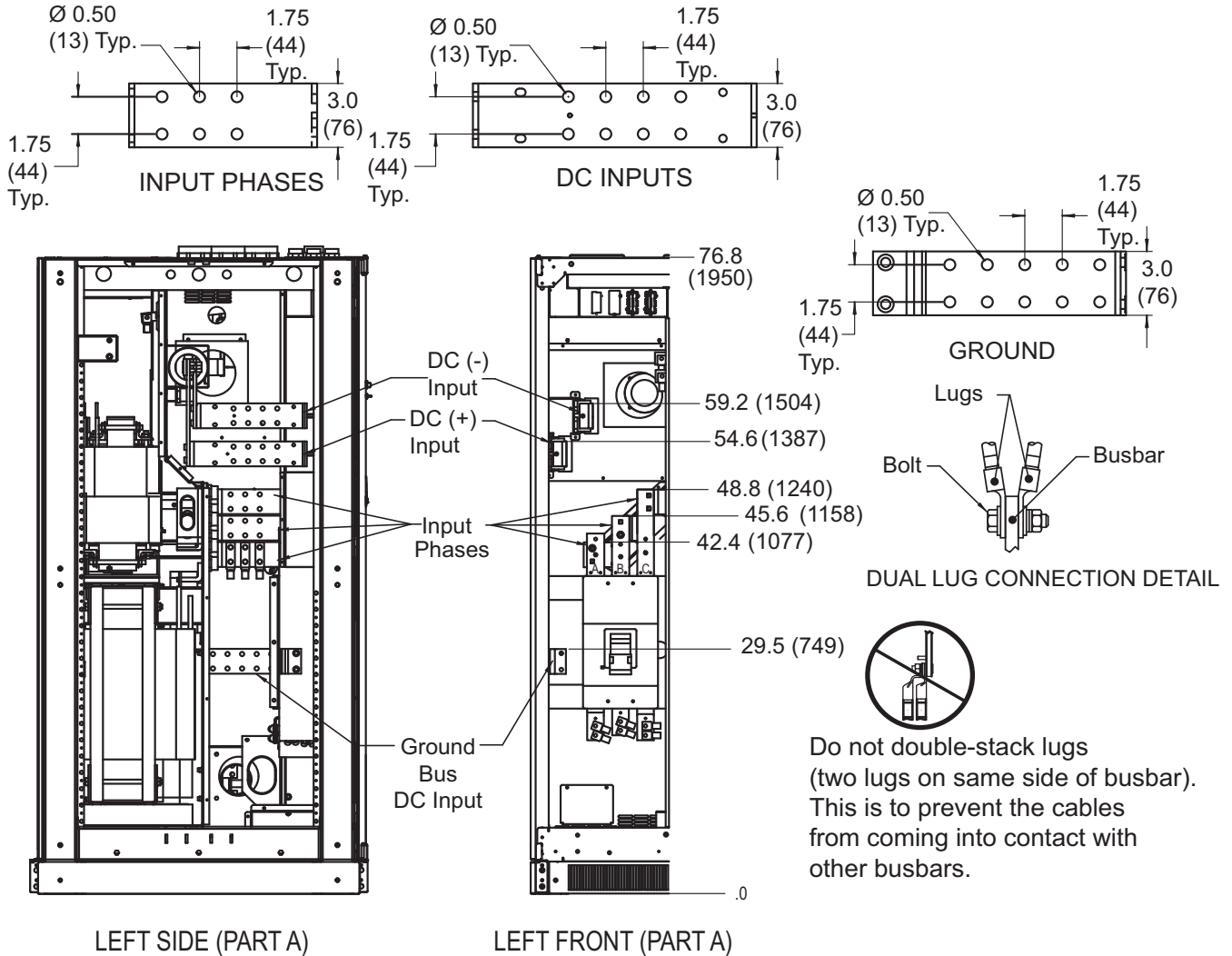




Figure 19 Outline drawing, Liebert NXL 500kVA UPS SMS and 1+N multi-module unit with static bypass



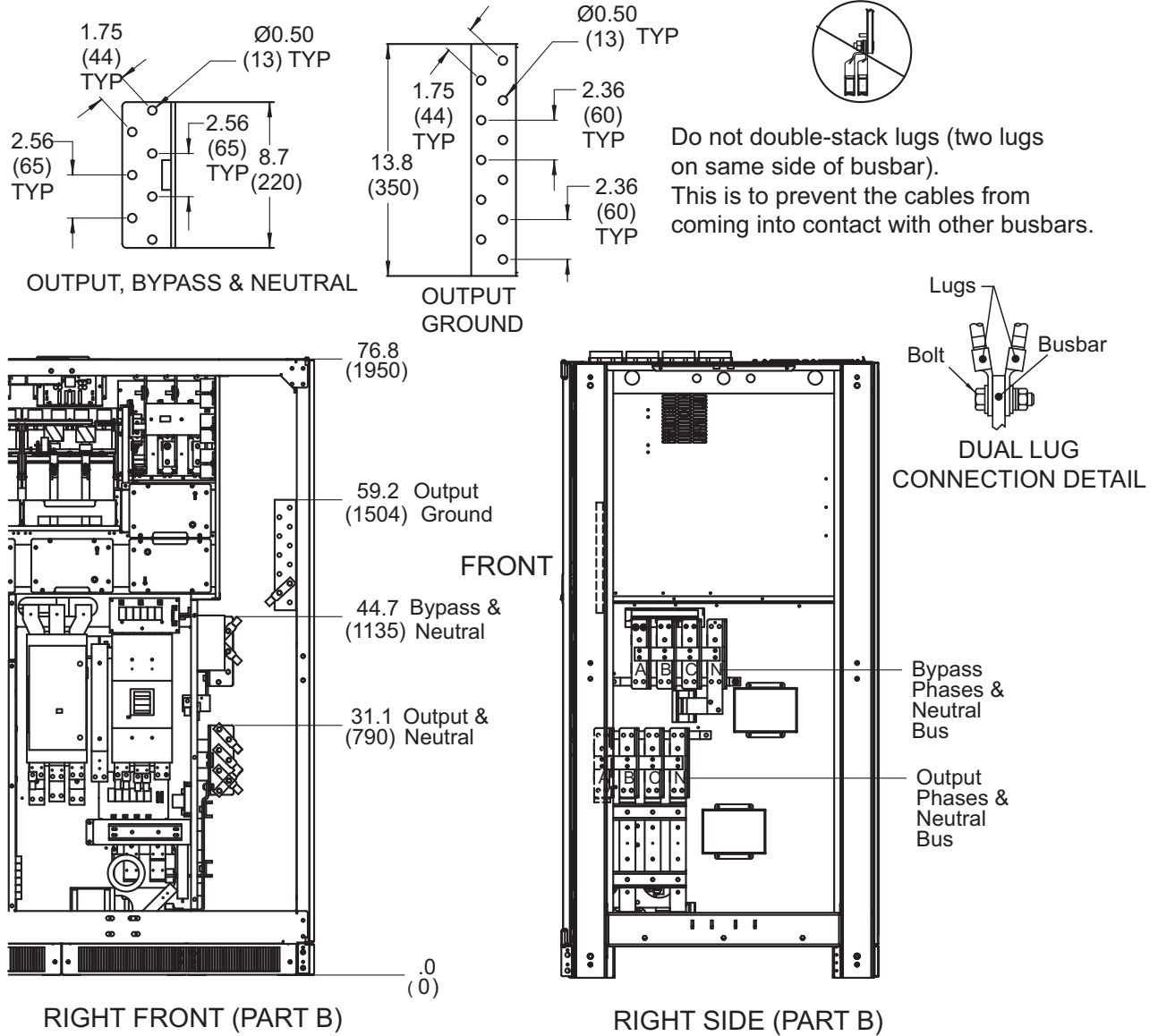
**Figure 20** Input terminal details, Liebert NXL 500kVA UPS, SMS and 1+N multi-module unit with static bypass



**NOTES**

1. All dimensions are in inches (mm).
2. Control wiring and power wiring must be run in separate conduit.
3. Unless otherwise noted, use copper or aluminum conductors suitable for at least 75°C.
4. All wiring is to be in accordance with national and local electrical codes.

Figure 21 Output terminal details, Liebert NXL 500kVA UPS, SMS and 1+N multi-module unit with static bypass



NOTES:

1. All dimensions are in inches (mm).
2. Unless otherwise noted, use copper or aluminum conductors suitable for at least 75°C.
3. All wiring is to be in accordance with national and local electrical codes.

**Figure 22 Base drawing, Liebert NXL 500kVA UPS, SMS and 1+N multi-module unit with static bypass**

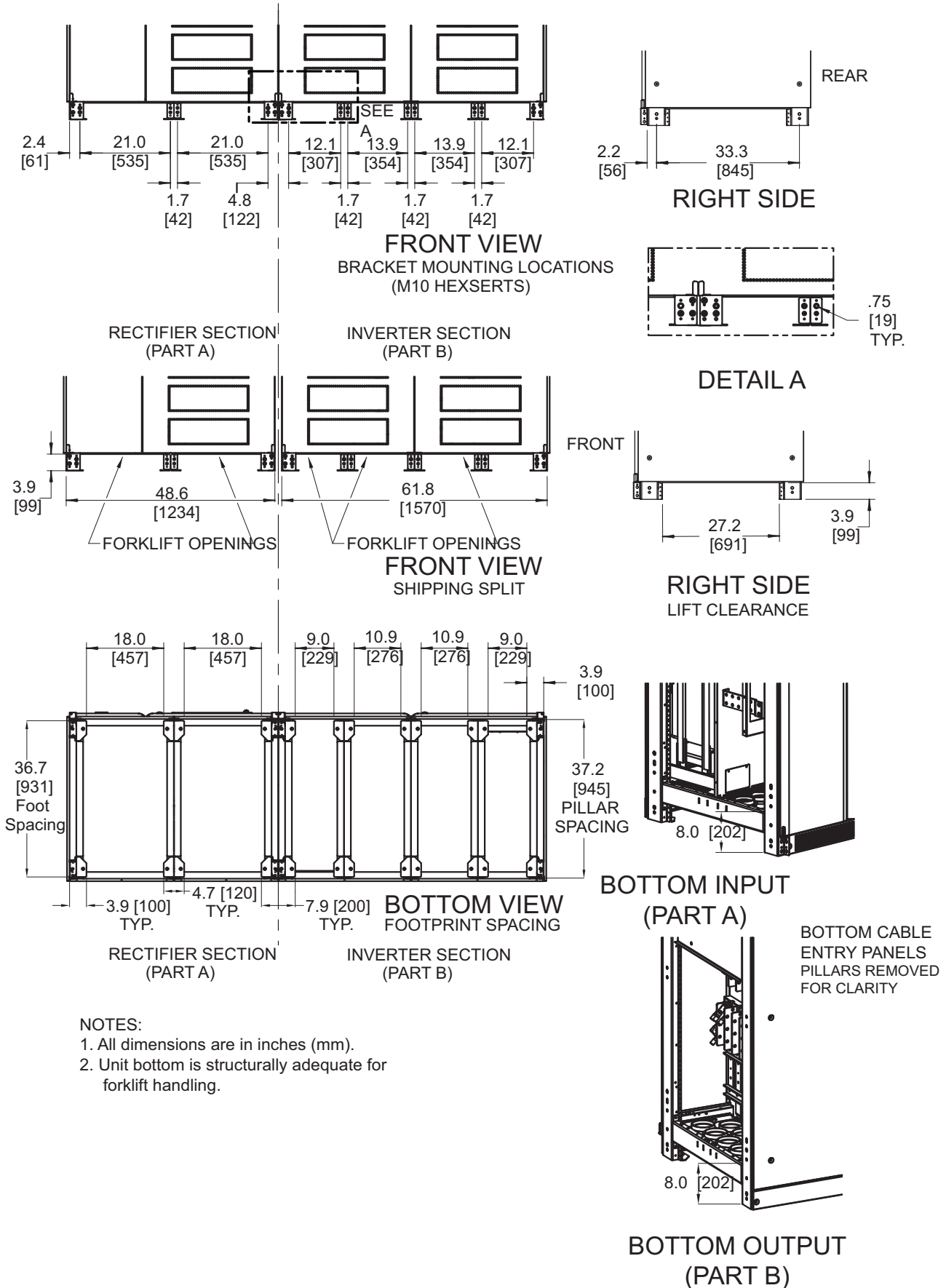
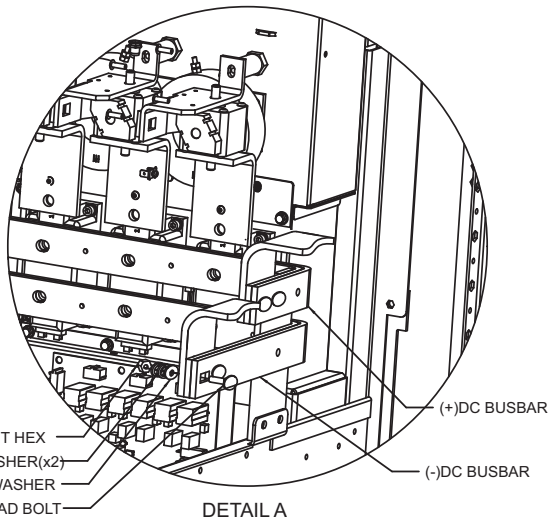
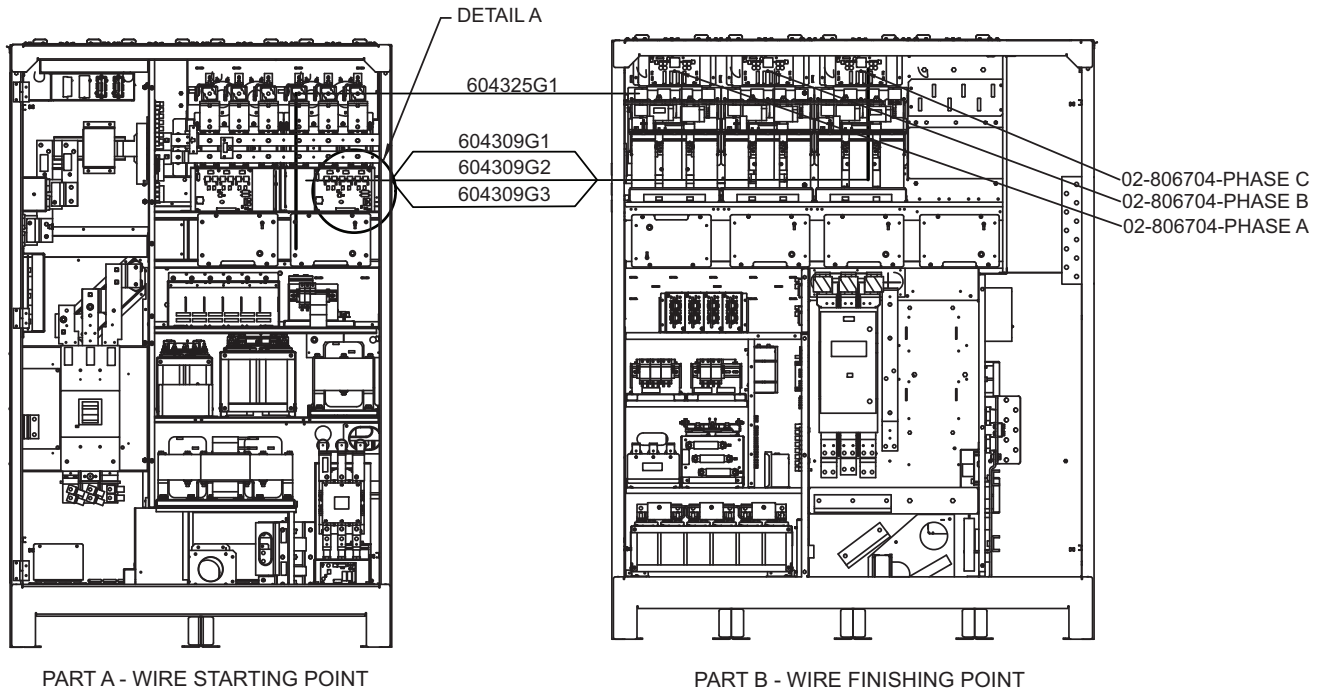


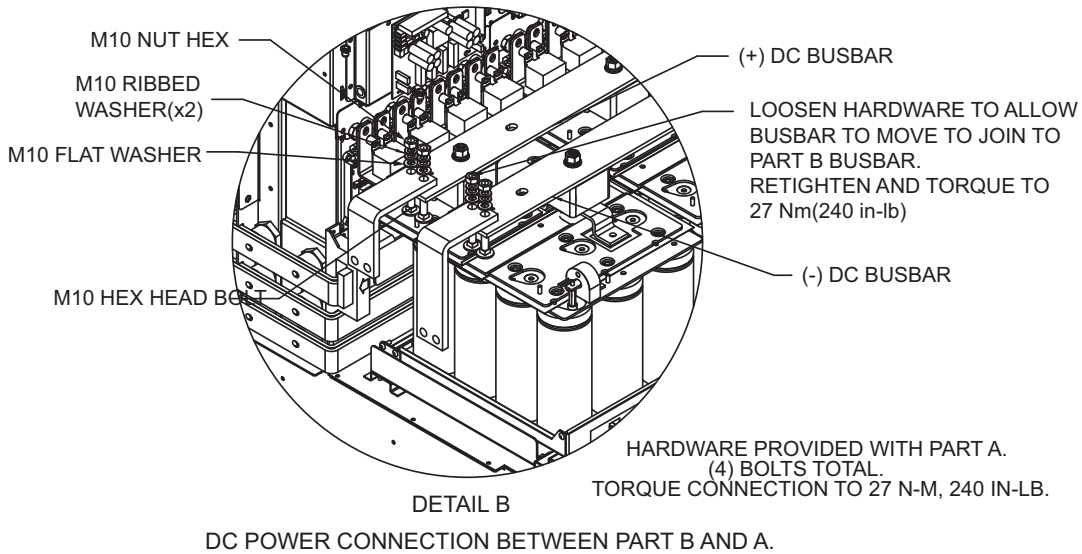
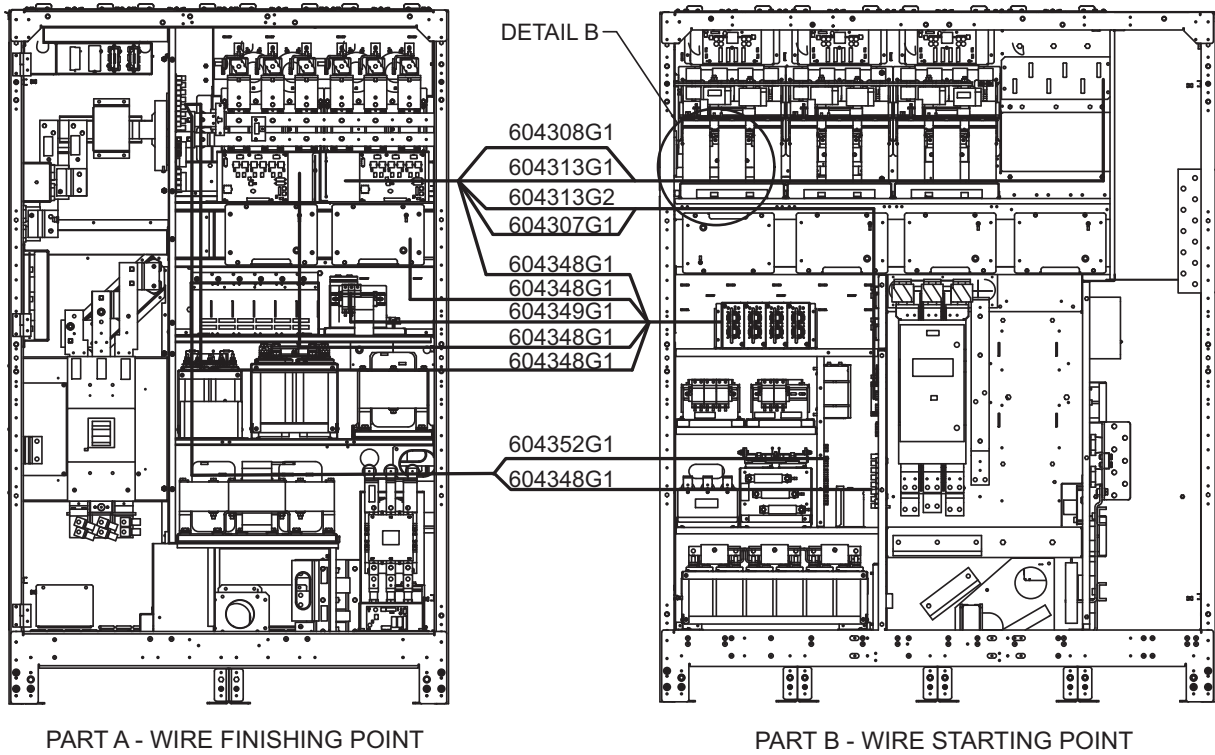
Figure 23 Field connections, shipping split 500kVA Liebert NXL, multi-module or SMS with static bypass, Page 1



DC POWER CONNECTION BETWEEN PART A AND B.  
 HARDWARE PROVIDED WITH PART B.  
 (4) BOLTS TOTAL.  
 TORQUE CONNECTION TO 27 N-M, 240 IN-LBS.

WH P/N	START (Part B- Inverter Cabinet)	FINISH (Part A- Rectifier Cabinet)	Label
604309G1	02-806704 Inverter Gate Drive A	UPSC	To: 02-806701 ID: P0400A
604309G2	02-806704 Inverter Gate Drive B	UPSC	To: 02-806701 ID: P0400B
604309G3	02-806704 Inverter Gate Drive C	UPSC	To: 02-806701 ID: P0400C
604325G1	DCFAN_2 & DCFAP_1 DC Fuseblock	02-806708 External Interface Board	To: 02-806708 ID: P0814

Figure 24 Field connections, shipping split 500kVA Liebert NXL, multi-module or SMS with static bypass, Page 2



<b>WH P/N</b>	<b>START (Part A- Rectifier Cabinet)</b>	<b>FINISH (Part B- Inverter Cabinet)</b>	<b>LABEL</b>
604308G1	UPSC	02-806705 Bypass Control Board	TO: 02-806705 ID: P0500
604313G1	UPSC	02-806705 Bypass Control Board	To: 02-806705 ID: P0501
604313G2	UPSC	02-806707 Load VI	To: 02-806707 ID: P0700
604307G1	UPSC	02-806707 Load VI	To: 02-806707 ID: P0701
604348G1	UPSC	Power Supply	To: Power Supply ID: P66A
604348G1	02-806708 External Interface Board	Power Supply	To: Power Supply ID: P66B
604348G1	HMI	Power Supply	To: Power Supply ID: P99A
604348G1	02-806710 Fan Interface Board#1	Power Supply	To: Power Supply ID: P99B
604348G1	UPSC	Power Supply	To: Power Supply ID: P1300
604348G1	UPSC	Power Supply	To: Power Supply ID: P1302
604349G1	F48-2&F49-2 Bypass PS Fuseblock	Power Supply	To: Power Supply ID: P1303
604349G1	F46-2&F47-2 Bypass PS Fuseblock	Power Supply	To: Power Supply ID: P1304
604348G1	02-806708 External Interface Board	Power Supply	To: Power Supply ID: P55
604352G1	02-806710 Fan Interface Board#1	02-806716 AC Power Distribution Board	To: 02-806716 ID: P1011A
604348G1	02-806710 Fan Interface Board#1	02-806710 FAN Interface Board#2	To: 02-806710 ID: P99

**Figure 25 Main components, 625/750kVA Liebert NXL, N+1 multi-module unit without static bypass**

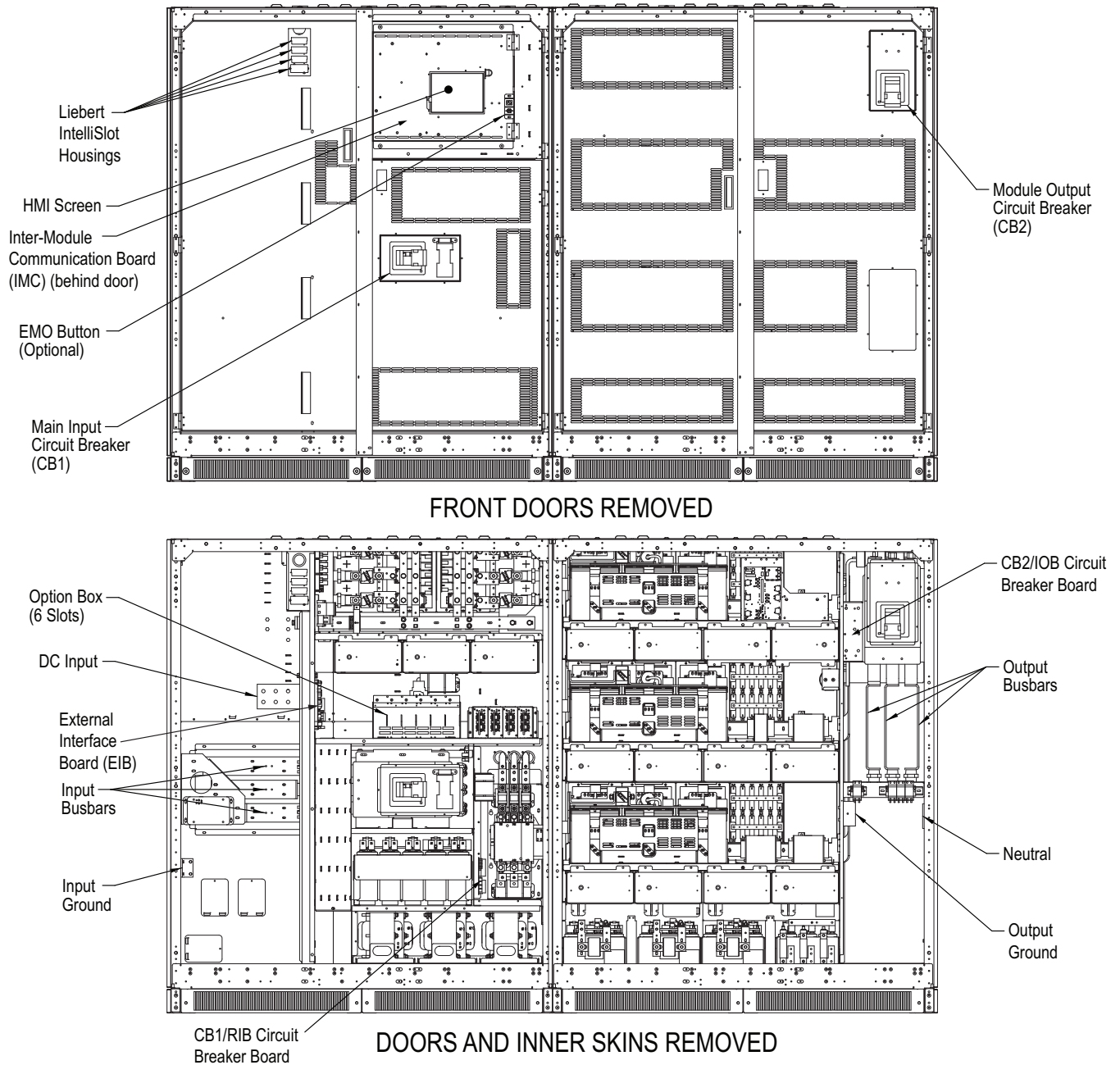
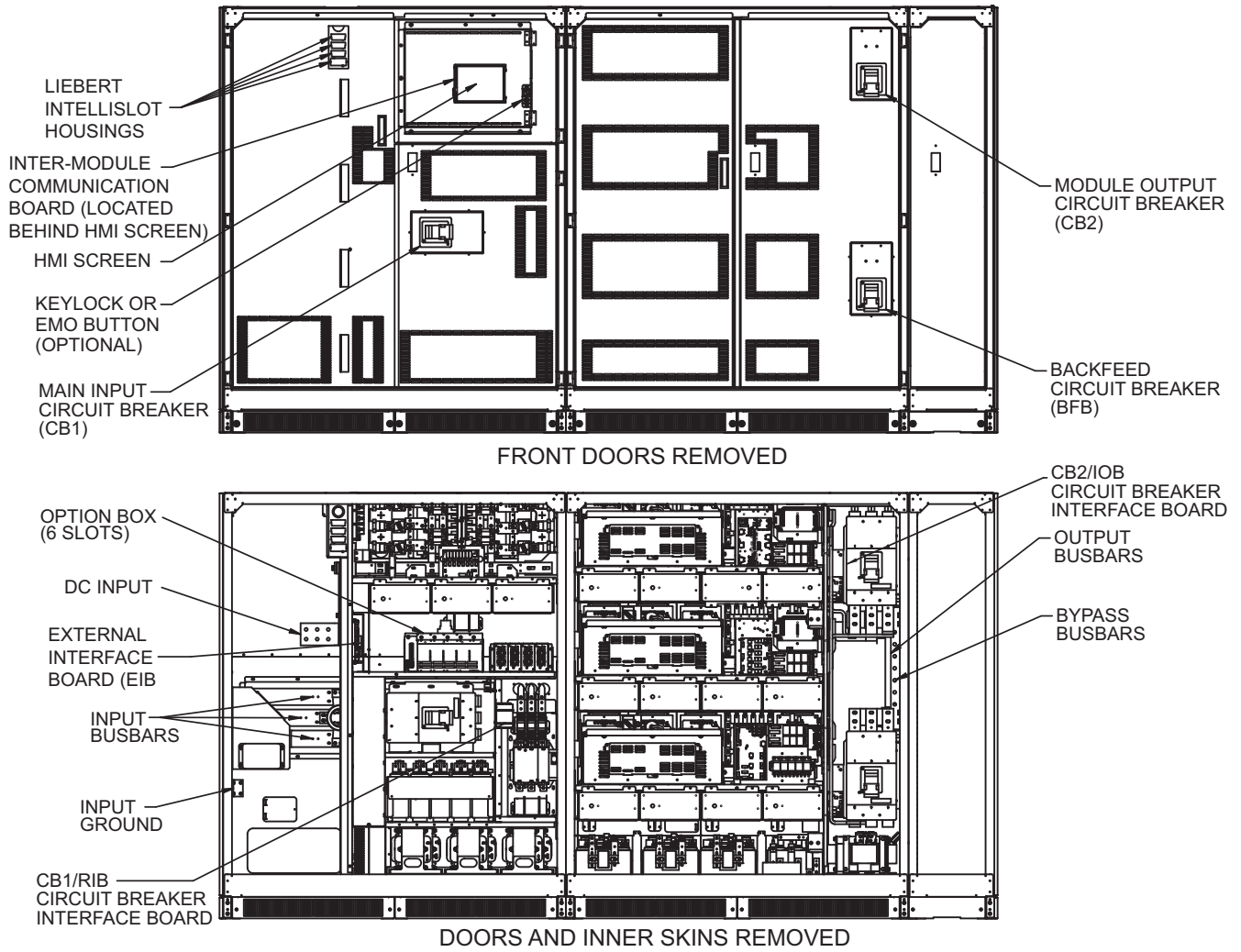
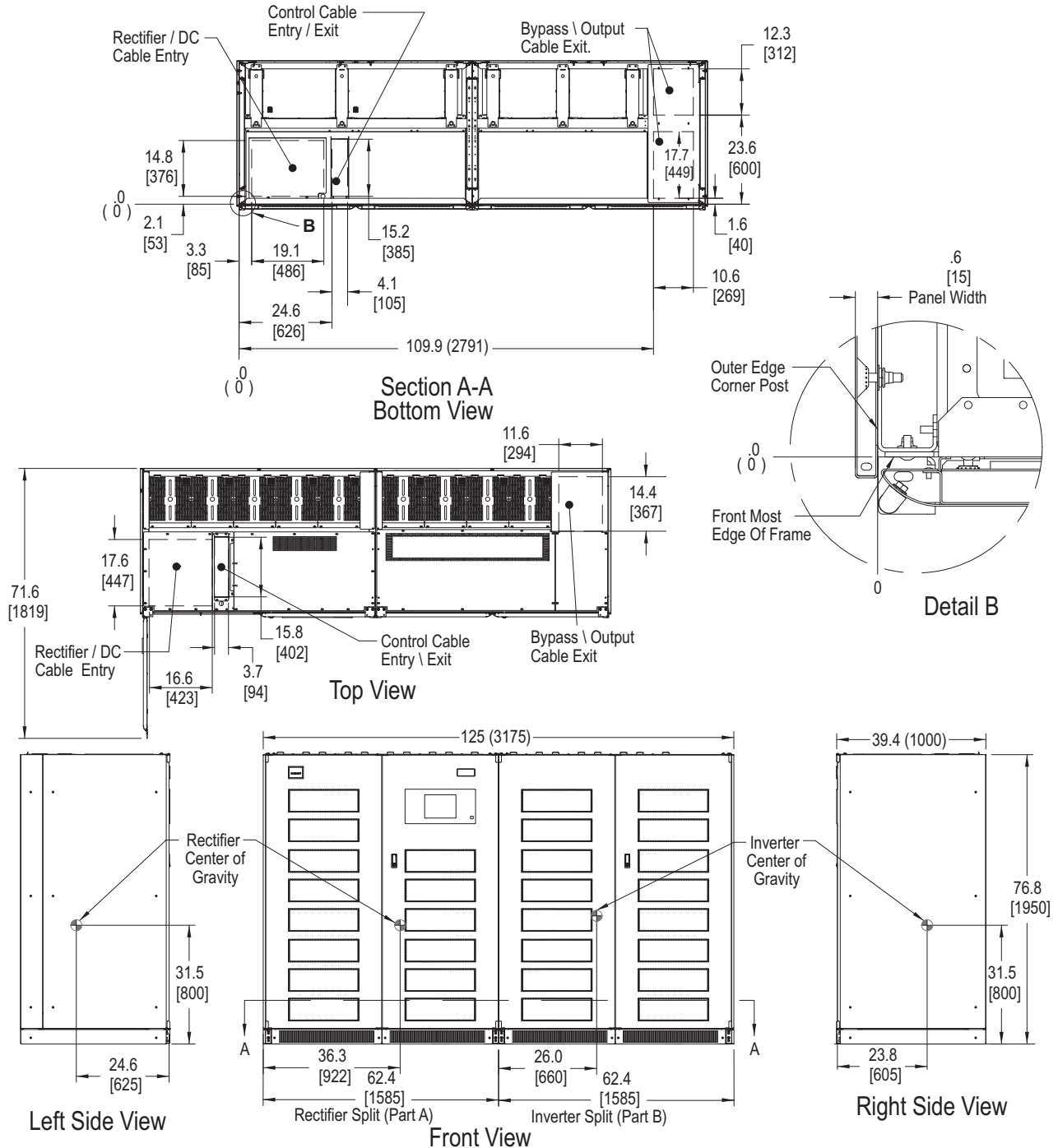




Figure 26 Main components, 625/750kVA Liebert NXL UPS, SMS and 1+N multi-module unit with static bypass



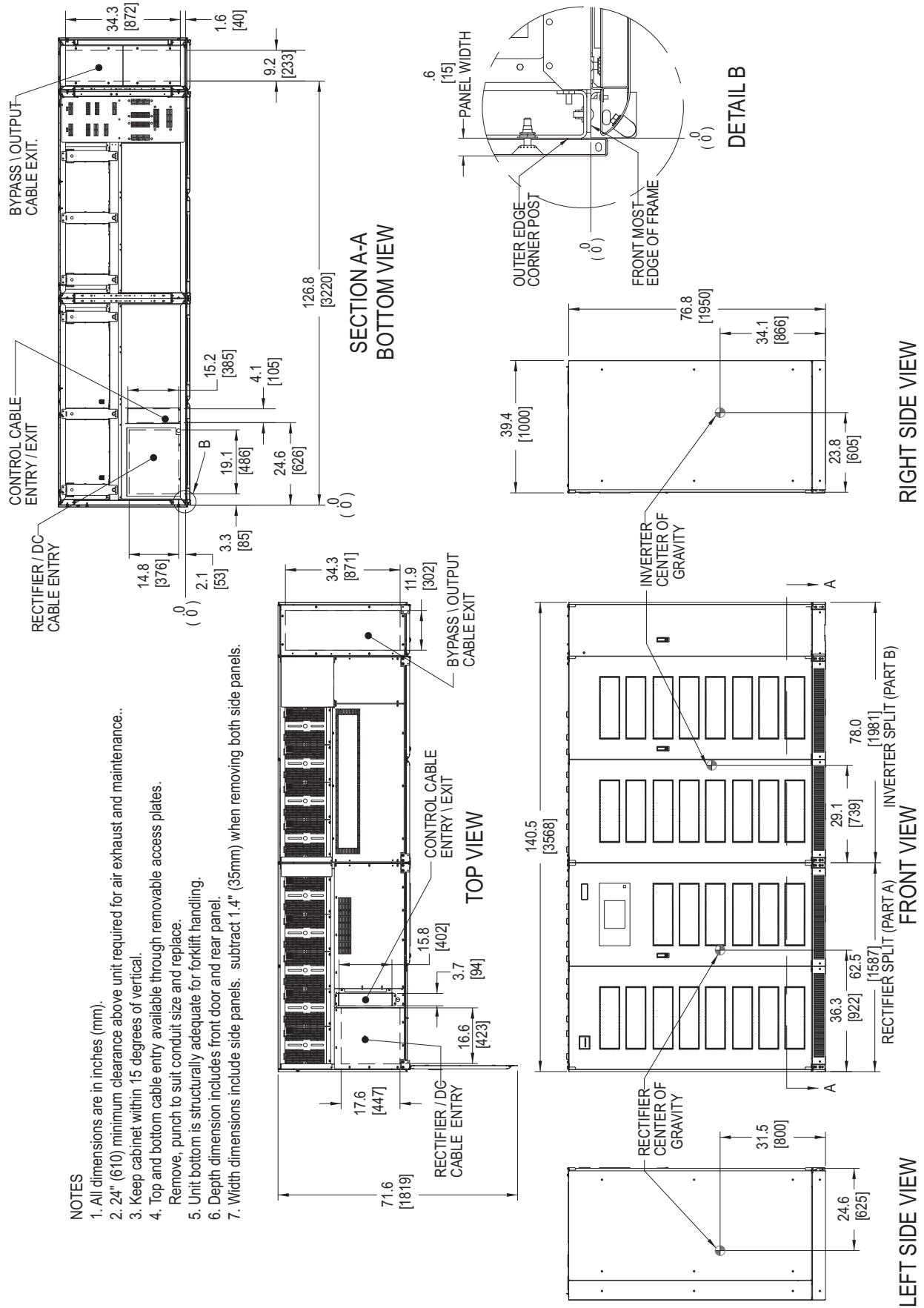
**Figure 27 Outline drawing, 625/750kVA Liebert NXL, N+1 multi-module unit without static bypass**



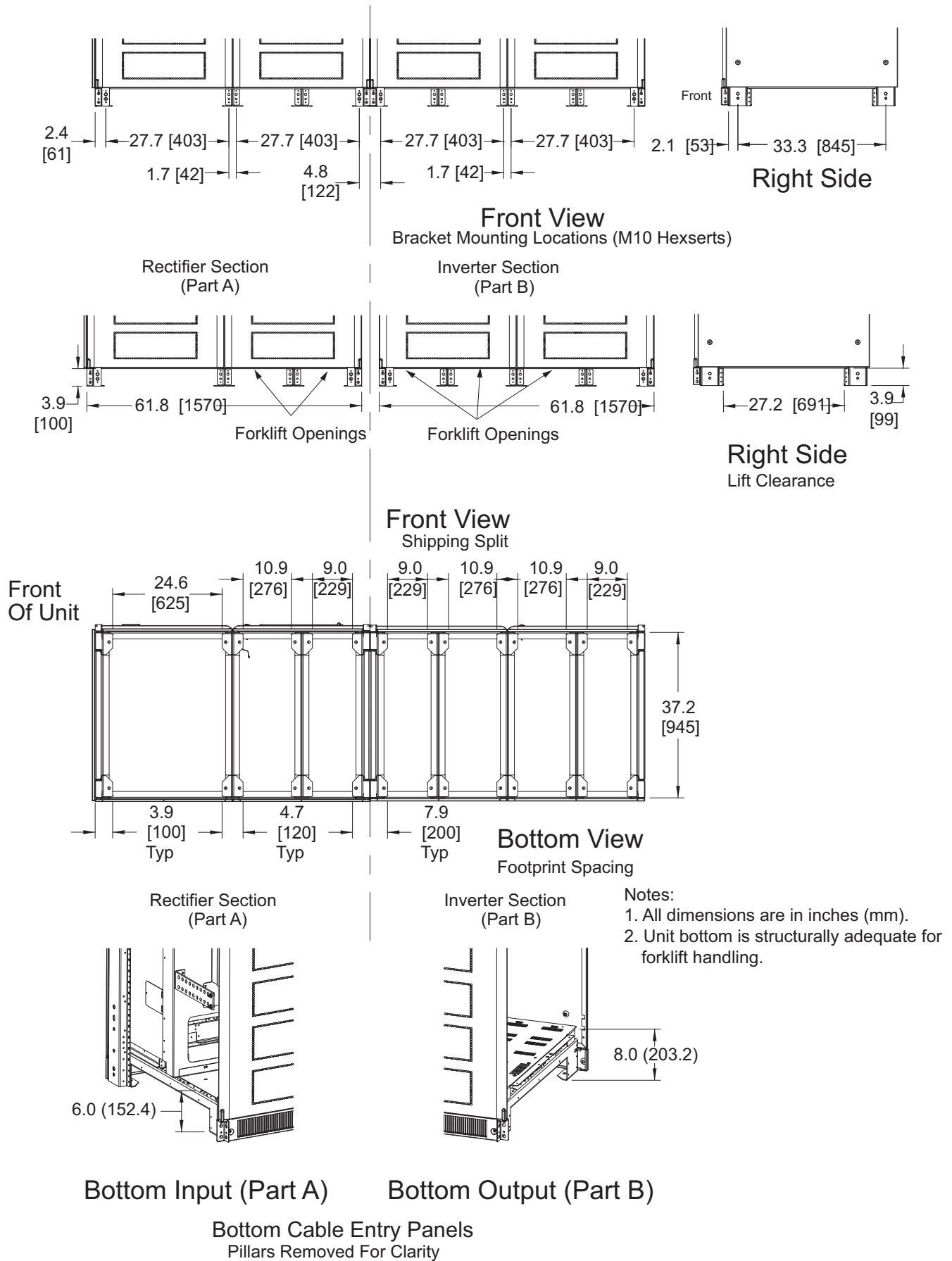
**NOTES**

1. All dimensions are in inches (mm).
2. 24" (610) minimum clearance above unit required for air exhaust and maintenance.
3. Keep cabinet within 15 degrees of vertical.
4. Top and bottom cable entry available through removable access plates.  
Remove, punch to suit conduit size and replace.
5. Unit bottom is structurally adequate for forklift handling.
6. Depth dimension includes front door and rear panel.
7. Width dimensions include side panels. Subtract 1.4" (35mm) when removing both side panels.

Figure 28 Outline Drawing, 625/750kVA Liebert NXL, SMS and 1+N multi-module unit with static bypass

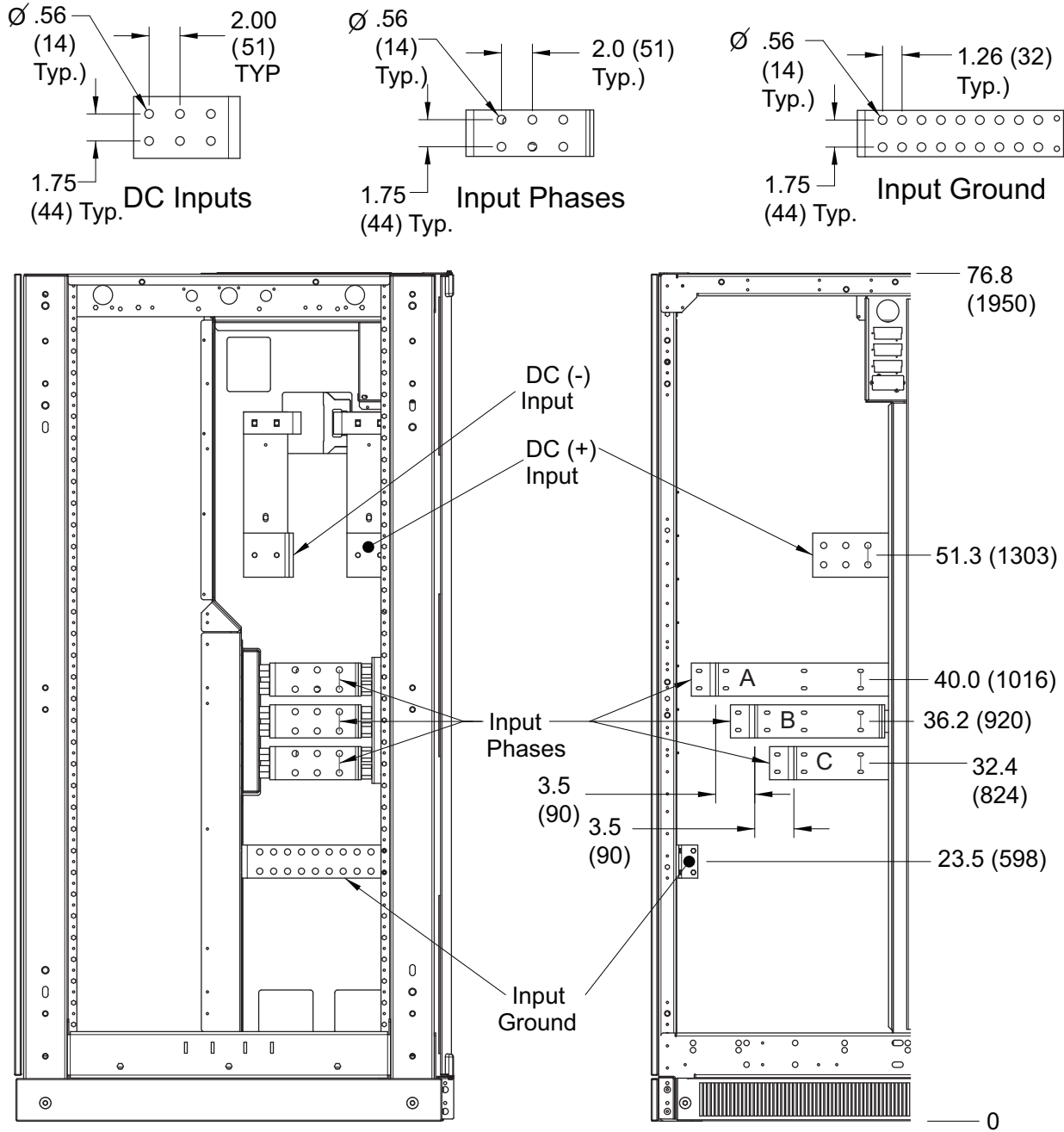


**Figure 29 Base detail drawing, 625/750kVA Liebert NXL, N+1 multi-module unit without static bypass**





**Figure 31 Input terminal detail, 625/750kVA Liebert NXL, N+1 multi-module unit without static bypass**

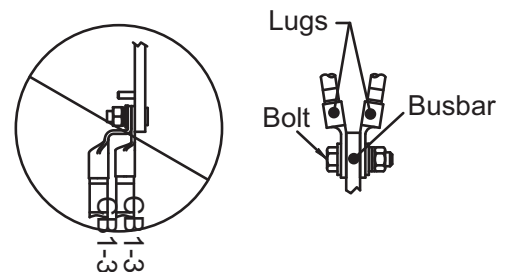


**LEFT SIDE (INPUT)**

**LEFT FRONT**

**Notes**

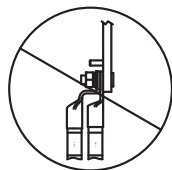
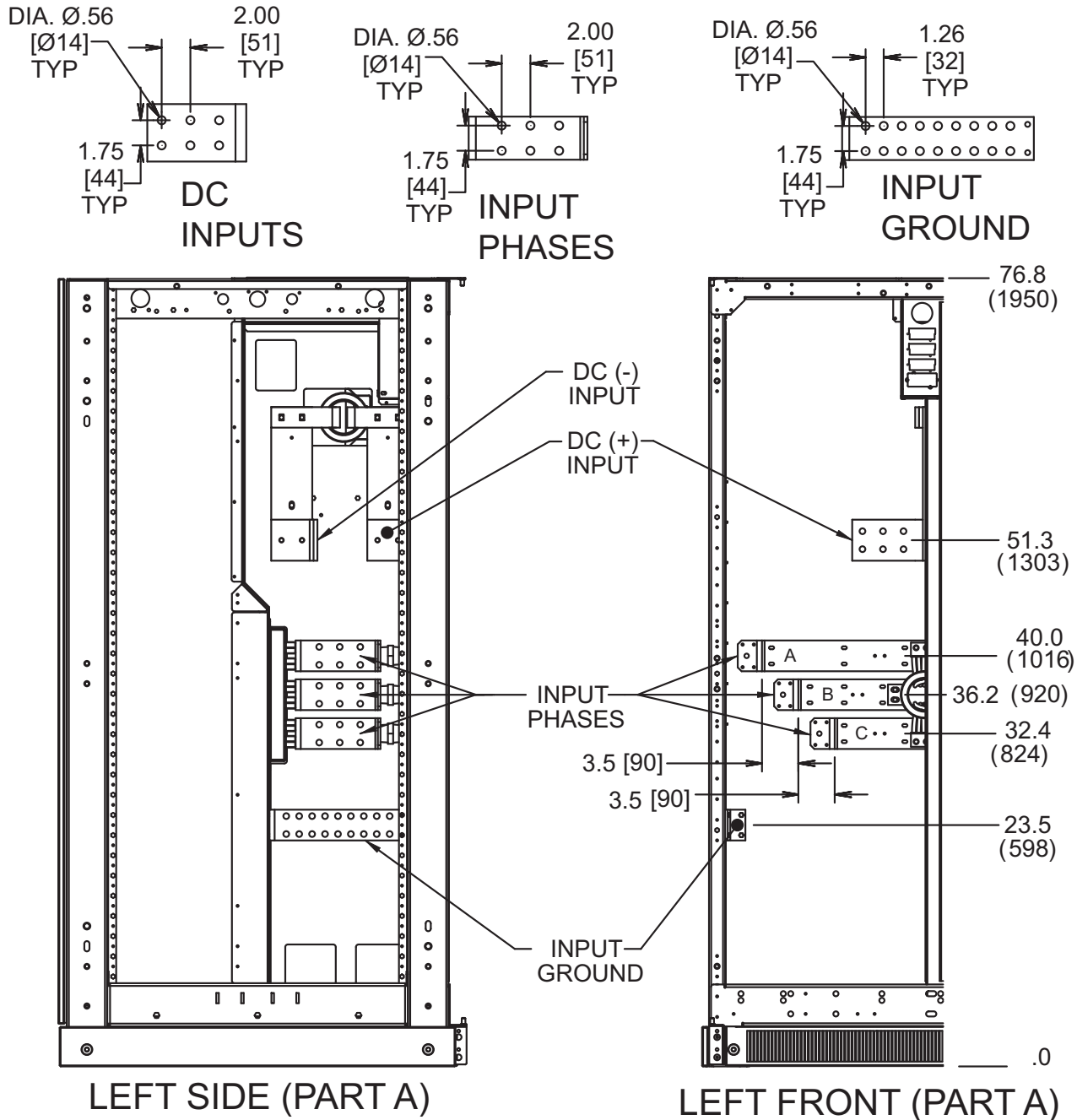
1. All dimensions are in inches (mm).
2. Control wiring and power wiring must be run in separate conduits.
3. Unless otherwise noted, use copper or aluminum conductors suitable for at least 75°C.
4. All wiring is to be in accordance with national and local electrical codes.



**DUAL LUG CONNECTION DETAIL**

Do not double-stack lugs (two lugs on same side of busbar). This is to prevent the cables from coming into contact with other busbars.

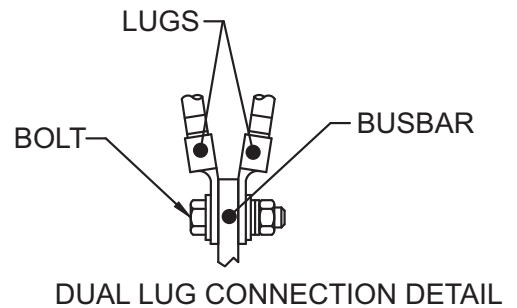
Figure 32 Input terminal detail, 625/750kVA Liebert NXL, SMS and 1+N multi-module unit with static bypass



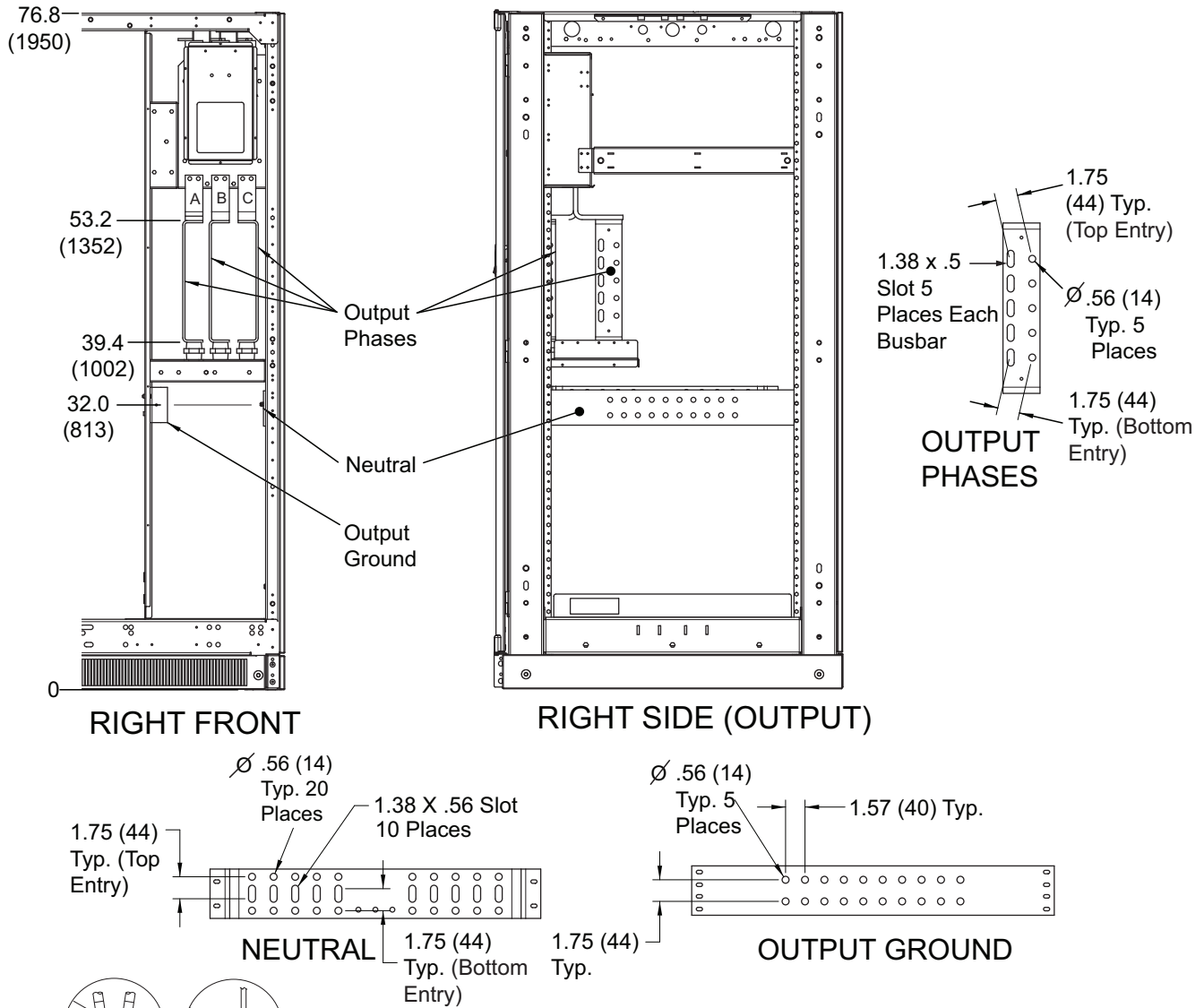
Do not double stack lugs (two lugs on same side of busbar). This is to prevent the cables from coming into contact with other busbars.

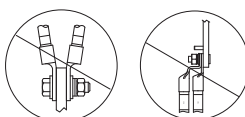
NOTES:

1. All dimensions are in inches (mm).
2. Control wiring and power wiring must be run in separate conduits.
3. Unless otherwise noted, use copper or aluminum conductors suitable for at least 75°C.
4. All wiring is to be in accordance with national and local electrical codes



**Figure 33 Output terminal detail, 625/750kVA Liebert NXL, N+1 multi-module unit without static bypass, cont'd**



  
DO NOT DOUBLE-STACK LUGS

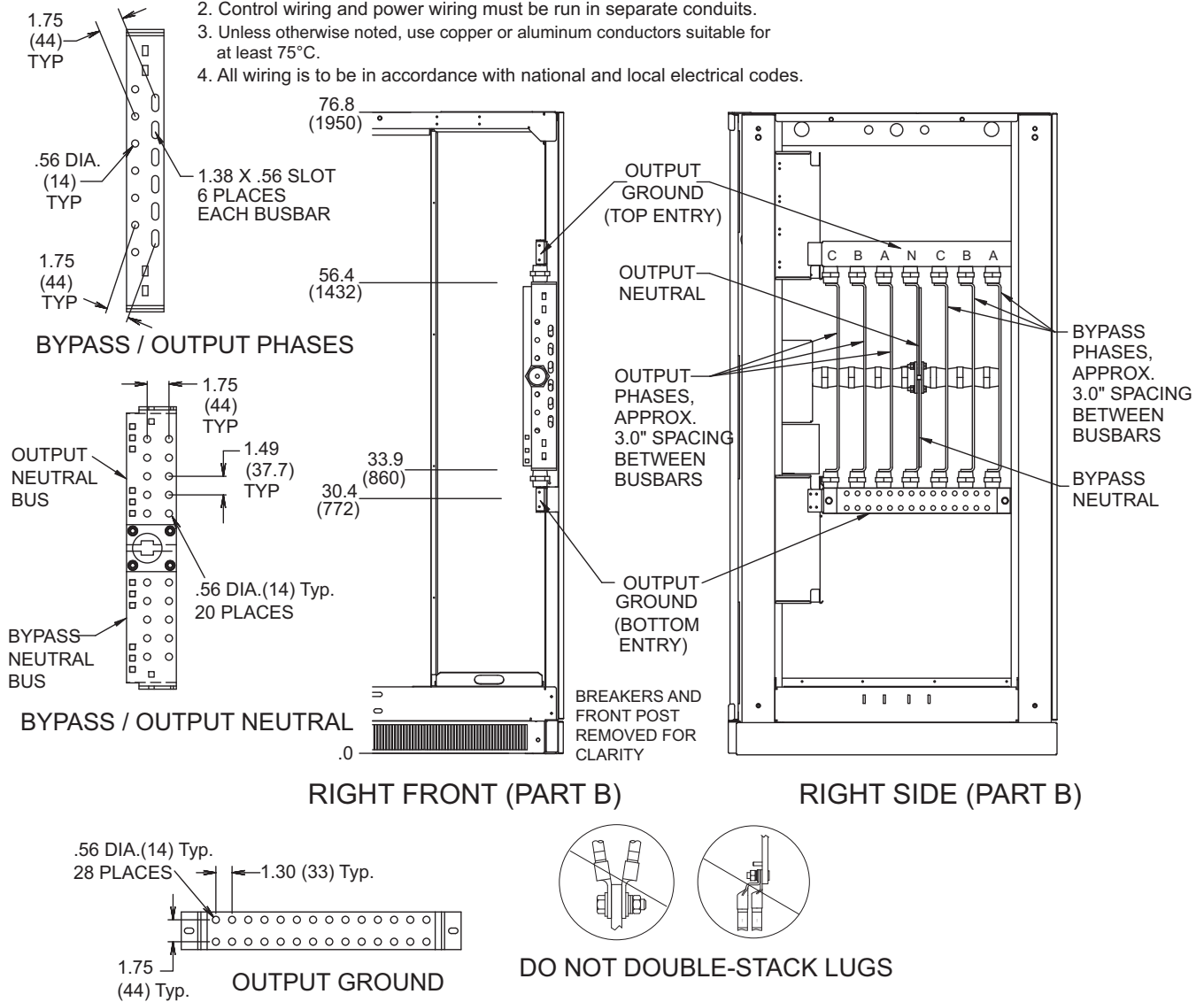
- NOTES:**
1. All dimensions are in inches (mm)
  2. Control wiring and power wiring must be run in separate conduits.
  3. Unless otherwise noted, use copper or aluminum conductors suitable for at least 75°C.
  4. All wiring is to be in accordance with national and local electrical codes.



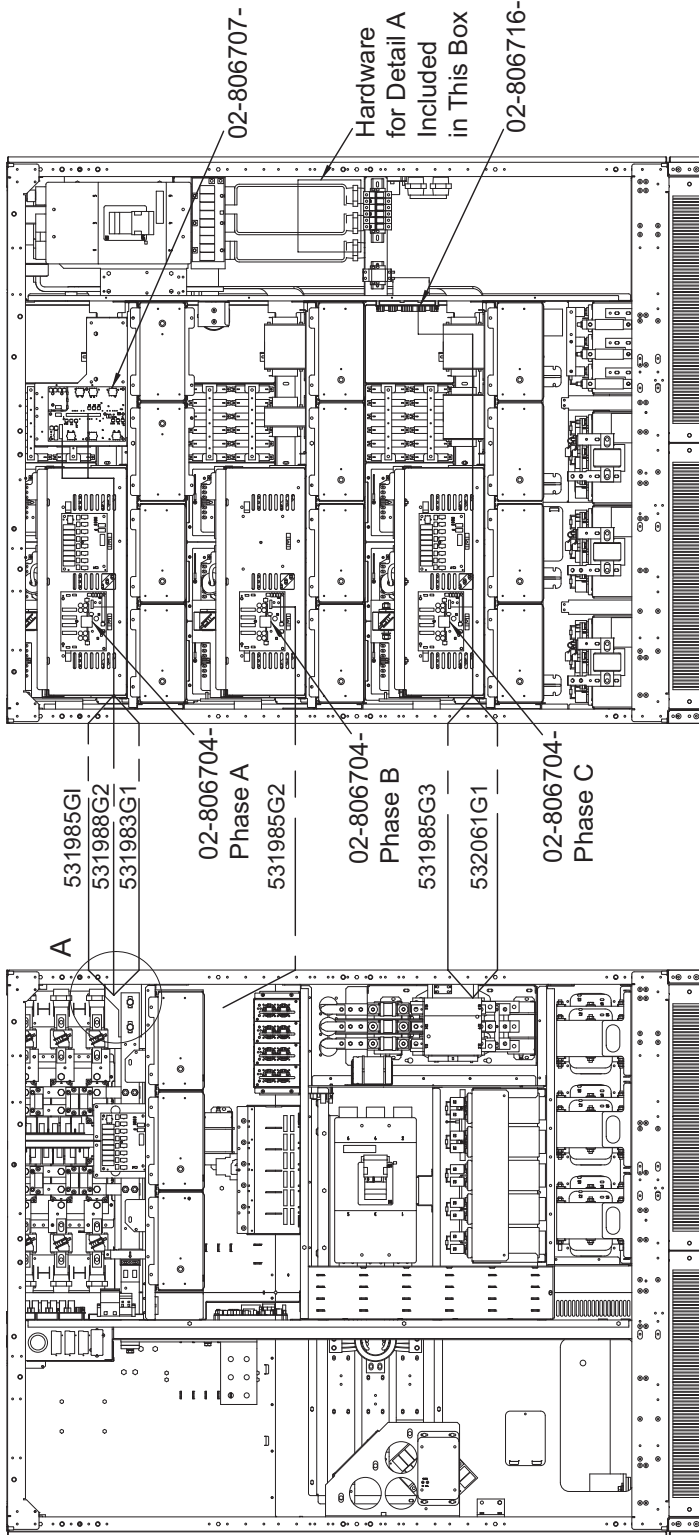
Figure 34 Output terminal detail, 625/750kVA Liebert NXL, SMS and 1+N multi-module unit with static bypass, cont'd

NOTES

1. All dimensions are in inches (mm).
2. Control wiring and power wiring must be run in separate conduits.
3. Unless otherwise noted, use copper or aluminum conductors suitable for at least 75°C.
4. All wiring is to be in accordance with national and local electrical codes.



**Figure 35 Shipping split 625/750kVA Liebert NXL without static bypass**



**Part A (Rectifier) - Wire Starting Point**

**Low-Voltage Wire Connections Between Part A and Part B**

Wires are coiled and tied in Part B.

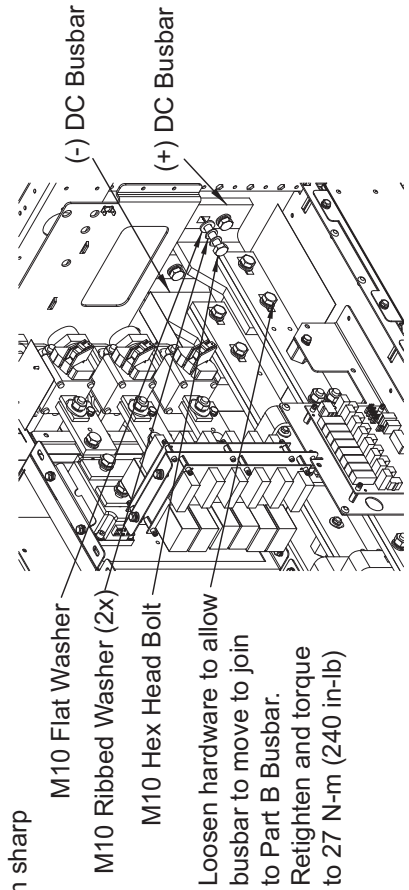
Uncoil, route and connect wires in finish part as shown. Use wire label as guide for "to" component, connection ID and wire part number. Tie wires away from sharp edges, busbar and electronic components.

**Part B (Inverter) - Wire Finishing Point**

**Detail A**

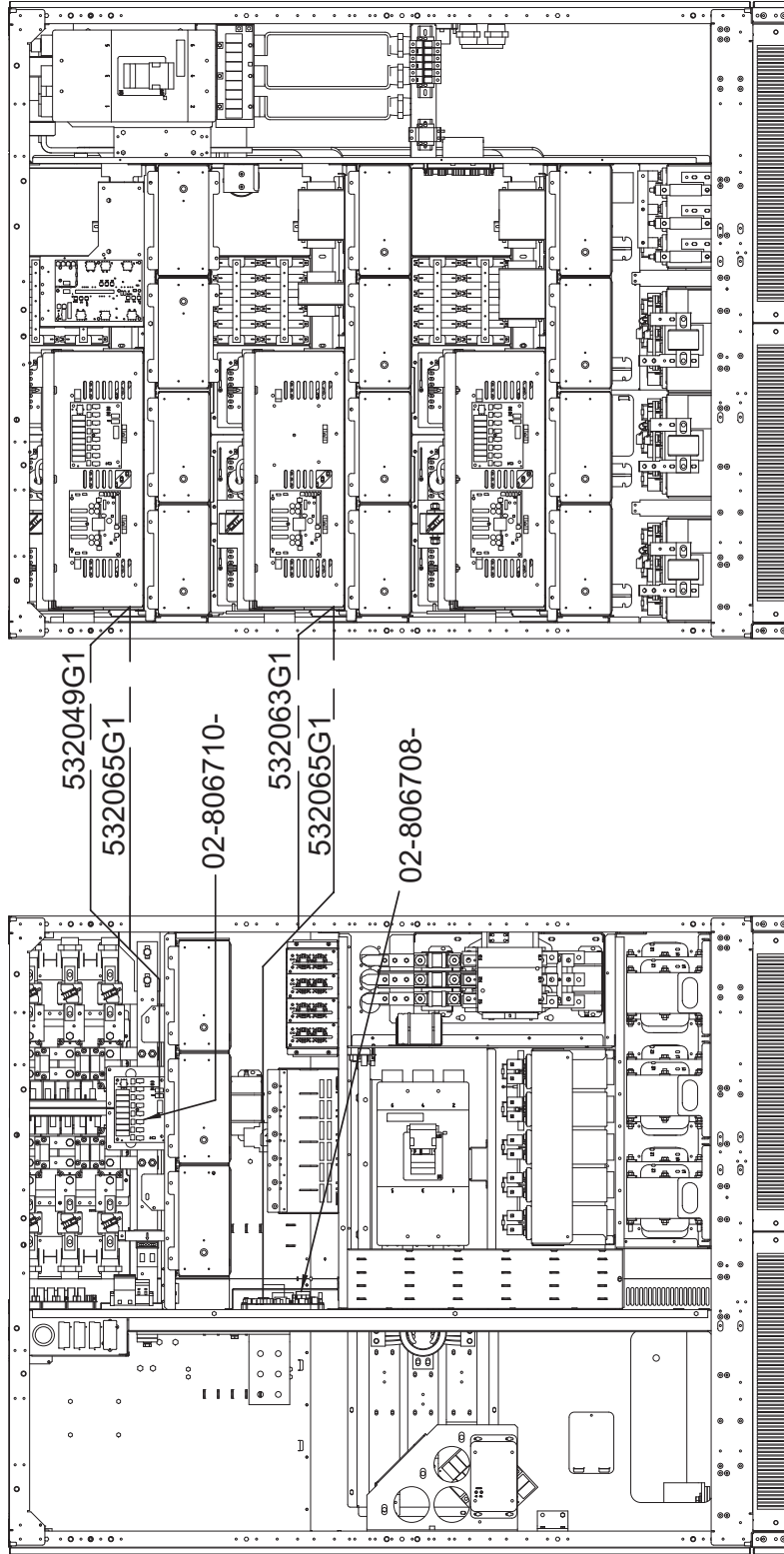
**DC Power Connection Between Part A and Part B**

Hardware Provided With Part B: 4 Bolts Total  
Torque Connection To 27 N-m (240 In-lbs)



<b>WH P/N</b>	<b>START (Part A - Rectifier Cabinet)</b>	<b>FINISH (Part B - Inverter Cabinet)</b>	<b>LABEL</b>
531985G1	UPSC (Control Door)	02-806704 - Inverter Gate Drive A	To: 02-806704- Phase A ID: P0400A
531988G2	UPSC (Control Door)	02-806707 - Load VI	To: 02-806707- ID: P0700
531983G1	UPSC (Control Door)	02-806707- Load VI	To: 02-806707- ID: P0701
531985G2	UPSC (Control Door)	02-806704 - Inverter Gate Drive B	To: 02-806704- Phase B ID: P0400B
531985G3	UPSC (Control Door)	02-806704 - Inverter Gate Drive C	To: 02-806704- Phase C ID: P0400C
532061G1	Power Supply	02-806716 - AC Distribution Board	To: 02-806716-__ Connection ID: P1305 WH P/N: 532061G1

**Figure 36 Shipping split 625/750kVA Liebert NXL without static bypass (continued)**



**Part B (Inverter) - Wire Starting Point**

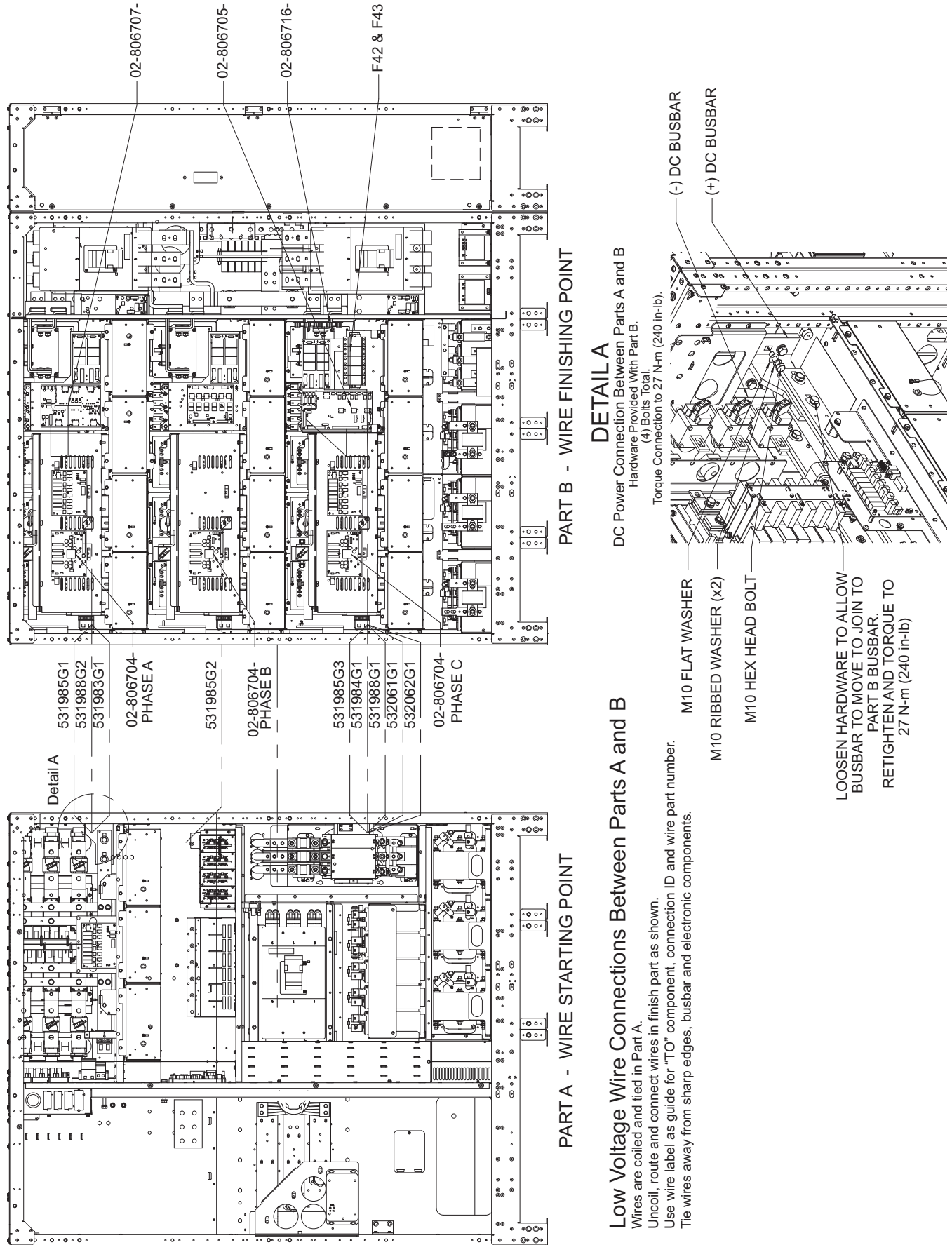
**Part A (Rectifier) - Wire Finishing Point**

**Low Voltage Wire Connections Between Part B and Part A**

Wires are coiled and tied in Part B.  
 Uncoil, route and connect wires in finish part as shown.  
 Use wire label as guide for "to" component, connection ID and wire part number.  
 Tie wires away from sharp edges, busbar and electronic components.

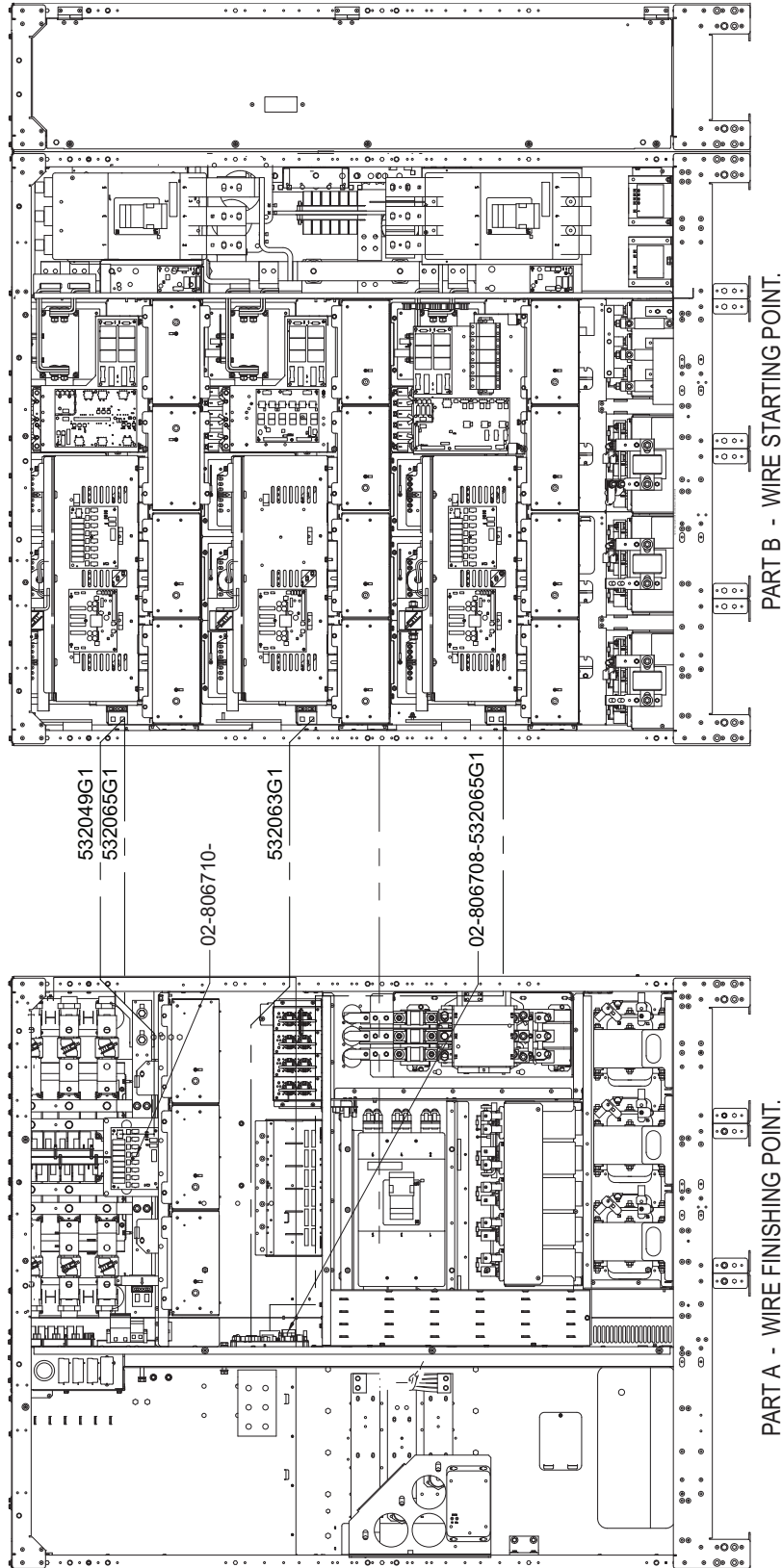
<b>WH P/N</b>	<b>START (Part B - Inverter Cabinet)</b>	<b>FINISH (Part A - Rectifier Cabinet)</b>	<b>LABEL</b>
532049G1	02-806716- AC Distribution Board	02-806710- Fan Interface Board 1	To: 02-806710-__ Connection ID: P1011 WH P/N: 532049G1
532065G1	02-806710- Fan Interface Board 2	02-806710- Fan Interface Board 1	To: 02-806710-__ Connection ID: P66 WH P/N: 532065G1
532063G1	DC Fuse	02-806708- External Interface Board	To: 02-806708-__ Connection ID: P0814 WH P/N: 532063G1
532065G1	02-806710- Fan Interface Board 3	02-806708- External Interface Board	TO: 02-806708-__ Connection ID: P99B WH P/N: 532065G1

**Figure 37 Shipping Split, 625/750kVA Liebert NXL, SMS and 1+N multi-module unit with static bypass**



<b>WH P/N</b>	<b>START (Part A - Rectifier Cabinet)</b>	<b>FINISH (Part B - Inverter Cabinet)</b>	<b>LABEL</b>
531985G1	UPSC (Control Door)	02-806704-Inverter Gate Drive A	To: 02-806704- Phase A ID: P0400A
531988G2	UPSC (Control Door)	02-806707-Load Vi	To: 02-806707-ID: P0700
531983G1	UPSC (Control Door)	02-806707-Load Vi	To: 02-806707- ID: P0701
531985G2	UPSC (Control Door)	02-806704-inverter Gate Drive B	To: 02-806704-Phase B ID: P0400B
531985G3	UPSC (Control Door)	02-806704-Inverter Gate Drive C	To: 02-806704-Phase C ID: P0400C
531984G1	UPSC (Control Door)	02-806705-Bypass Control Board	To: 02-806705-ID: P0500
531988G1	UPSC (Control Door)	02-806705-Bypass Control Board	To: 02-806705-ID: P0501
532061G1	Power Supply	02-806716-AC Distribution Board	To: 02-806716-__ Connection ID: P1305 WH P/N: 532061G1
532062G1	Power Supply	02-806705- Bypass Control Board	To: 02-806705-__ Connection ID: P44 WH P/N: 532062G1
532062G1	Power Supply	F42-2 & F43-2 Bypass PS Fuseblock	To: F42-2 and F43-2 WH P/N: 532062G1

**Figure 38 Shipping Split, 625/750kVA Liebert NXL, SMS and 1+N multi-module unit with static bypass, continued**



**Low Voltage Wire Connections Between Parts B and A**

Wires are coiled and tied in Part B.  
 Uncoil, route and connect wires in finish part as shown.  
 Use wire label as guide for "TO" component, connection ID and wire part number.  
 Tie wires away from sharp edges, busbar and electronic components.



<b>WH P/N</b>	<b>Start (Part B - Inverter Cabinet)</b>	<b>Finish (Part A - Rectifier Cabinet)</b>	<b>Label</b>
532049G1	02-806716-AC Distribution Board	02-806710- Fan Interface Board 1	To: 02-806710-__ Connection ID: P1011 WH P/N: 532049G1
532065G1	02-806710-Fan Interface Board 2	02-806710- Fan Interface Board 1	To: 02-806710-__ Connection ID: P66 WH P/N: 532065G1
532063G1	DC Fuse	02-806708- External Interface Board	To: 02-806708-__ Connection ID: P0814 WH P/N: 532063G1
532065G1	02-806710-Fan Interface Board 3	02-806708- External Interface Board	To: 02-806708-__ Connection ID: P99B WH P/N: 532065G1

**Figure 39** Single-input wire cabinet

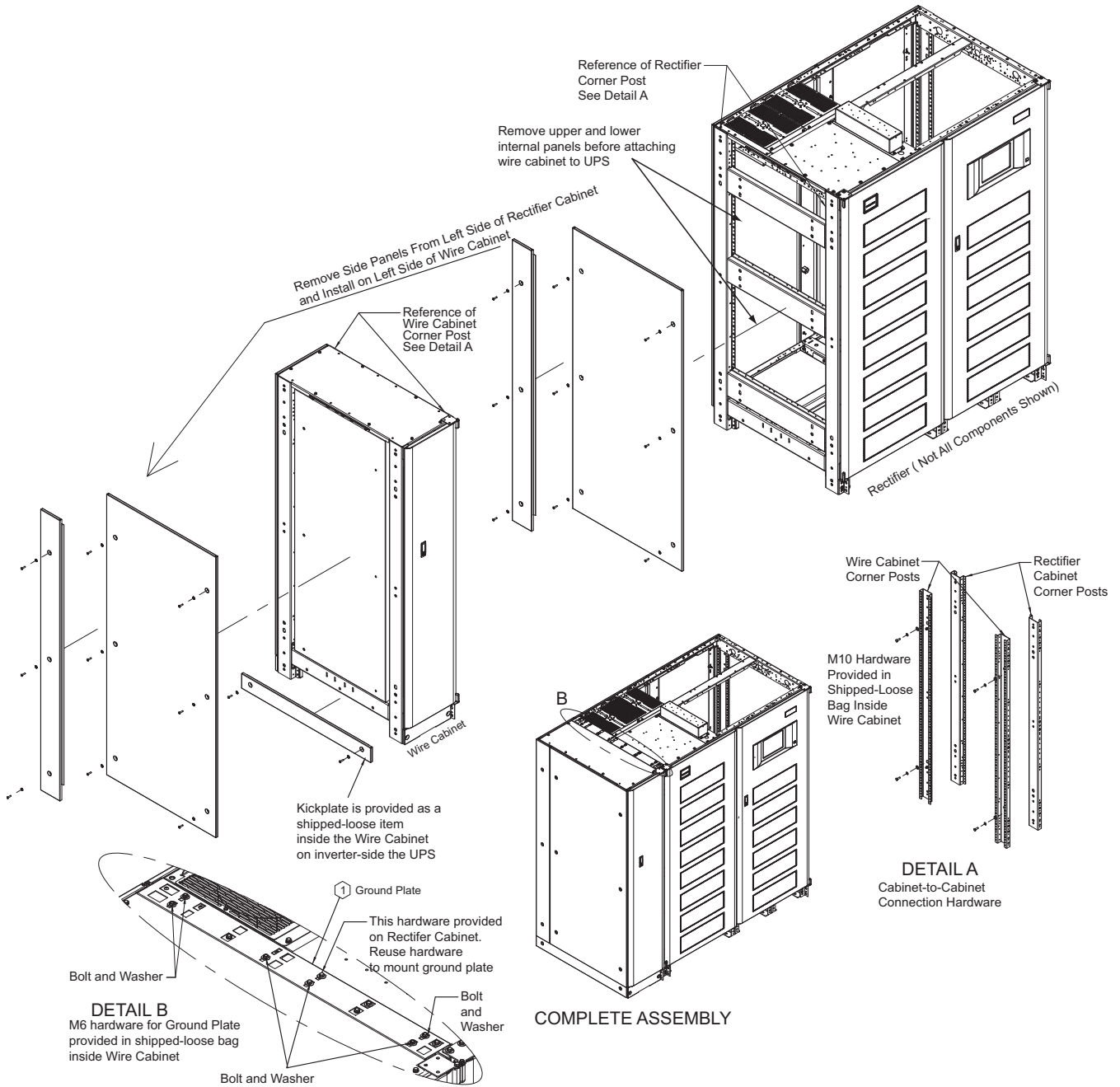
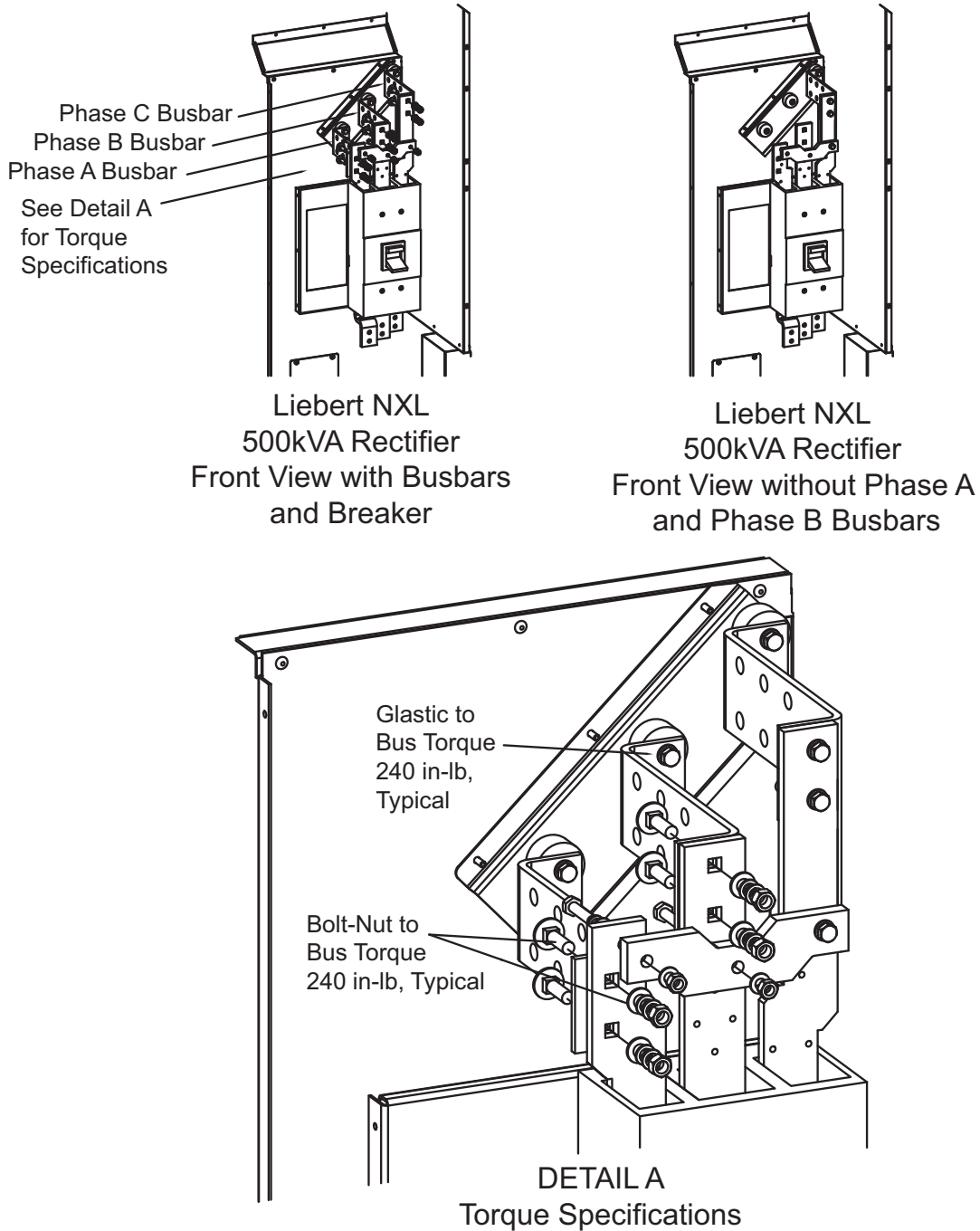


Figure 40 Alternate Liebert NXL 500kVA bottom cable entry



Phase A and Phase B busbars can be removed to ease bottom cable entry on the Liebert NXL 500kVA. The cables can be pulled and lugged.

1. Install Phase C cables.
2. Install Phase B busbar as shown in **Figure 40**.
3. Install Phase B cables.
4. Install Phase A busbar as shown in **Figure 40**.
5. Install Phase A cables.
6. Verify that all busbar bolt connections are torque properly.

## 4.1 PROGRAMMABLE RELAY BOARD

The Programmable Relay Board (PRB) provides a means to trigger an external device when an event occurs in the Liebert NXL. Each PRB has eight channels. Each channel has Form-C dry contacts rated at 1A @ 30VDC or 125VAC @ 0.45A.

Any alarm/event can be programmed to any channel or channels. Up to four (4) events can be programmed to a relay. If multiple events are grouped to one relay, group the events logically to simplify troubleshooting when an event is triggered. The same alarm/event can be programmed to more than one channel. Up to two Programmable Relay Boards can be installed in the Liebert NXL for a total of 16 channels. Programming is performed through the HMI touchscreen display.



### NOTE

Up to two (2) PRB's can be installed in the Liebert NXL.

**Figure 41 Control wiring, Programmable Relay Board**



1. Customer control wiring connection points are terminals 1 through 15. (Pin 16 not used on J71, J72, and J73.)
2. Programmable Relay Board option includes eight signal channels with two Form-C dry contacts per channel (see **Table 12**).
3. All control wiring (by others) must be run separate from power wiring. Control wiring runs should not be combined in the same conduit.
4. Contact ratings: 1A @ 30VDC or 125VAC @ 0.45A
5. Maximum cable length 500 ft. (152m) with #16AWG and flexible stranded cable.
6. All wiring must be in accordance with national and local electrical codes.

**Table 12 Programmable Relay Board pinout**

Terminal Block	Channel	Pin No.	Common	Normally Closed	Normally Open	
J71	CH1	A	1-3	1	2	3
		B	4-6	4	5	6
	CH2	A	7-9	7	8	9
		B	10-12	10	11	12
J72	CH3	A	13-15	13	14	15
		B	1-3	1	2	3
	CH4	A	4-6	4	5	6
		B	7-9	7	8	9
	CH5	A	10-12	10	11	12
		B	13-15	13	14	15
TB3	CH6	A	1-3	1	2	3
		B	4-6	4	5	6
	CH7	A	7-9	7	8	9
		B	10-12	10	11	12
	CH8	A	13-15	13	14	15
		B	1-3	1	2	3

Note: Pin 16 not used on J71, J72, and J73.

# 5.0 SPECIFICATIONS

**Table 13 Liebert NXL UPS specifications**

Model Size	500kVA	625kVA	750kVA
<b>Input Parameters</b>			
Input Voltage to Rectifier, VAC	480V 3-phase, 3-wire	480V 3-phase, 3-wire	480V 3-phase, 3-wire 575V 3-phase, 3-wire 600V 3-phase, 3-wire
Input Voltage to Bypass, VAC	480V 3-phase, 3-wire or 4-wire	480V 3-phase, 3-wire or 4-wire	480V 3-phase, 3-wire or 4-wire 575V 3-phase, 3-wire or 4-wire 600V 3-phase, 3-wire or 4-wire
Input Voltage Range, VAC	+10% to -15%; -15% to -20% <sup>1</sup> ; -20% to -30% <sup>2</sup> ; <-30% <sup>3</sup>		
Input Frequency, Hz	60		
Permissible Input Frequency Range, Hz	55 to 65		
Reflected Input THDi, Nominal Voltage, Full Load, %	<5%		
Power Walk-In, sec	1 to 30 (selectable) in 1 sec. Increment		
Bypass Neutral Current	up to 1.7 times full-phase current		
<b>Battery &amp; DC Parameters</b>			
Battery Type	VRLA (Valve Regulated Lead Acid) or FLA (Flooded Lead Acid)		
Nominal Battery Bus, VDC	480V		
Battery Float Voltage, VDC	540V		
Minimum End of Discharge Voltage, VDC	384V (for VRLA / Flooded Lead Acid)		
DC Ripple Voltage in Float & Const V Ch. Mode, %	<1 (RMS value) < 3,4% Vpp		
Temperature Compensated Battery Charging	Optional (with temperature probe)		
<b>Output Parameters</b>			
Inverter Type	IGBT-based Sine-Sine PWM Controlled		
Output Power for 0.9 PF Rating, kW	450	562.5	675
Output Voltage, VAC	480V 3-ph, 4-wire	480V 3-ph, 4-wire	480V 3-ph, 4-wire 575V 3-ph, 4-wire 600V 3-ph, 4-wire
Output Voltage Regulation, %	< 1% (3-phase RMS average)		
Output Voltage Regulation (100% Unb. Load)	< 2% (3-phase RMS average)		
Output Frequency, Hz	60		
Output Frequency Regulation, %	± 0.1		
Output THDv Linear Load at Nominal Voltage, %	<2%		
Output THDv at Nominal Voltage Including a 100kVA Non Linear Load per EN 62040-3, %	2.5% (max)		
Capacity to Handle High Crest Factor Load	3:1		
Capacity to handle Step Load, %	0-100 or 100-0		
Step Load Transient Recovery (linear loads), %	Within 5% peak-to-peak in one line cycle.		
Unbalance Loads Current Capacity	100% of nominal phase current		
<b>Capacity to Handle Leading PF Load</b>			
0.9 lag to Nom	Subject to Max. kW rating		
at 0.95 Lead	Subject to Max. kW rating		
at 0.9 Lead	Subject to 12.5% kW derate or same Rating and 10°C Temp. Derate		
Voltage Displacement, ° el	120° ±1° el (with 100% unbalanced load)		
Compliance to FCC Class-A	Standard		
Overload Conditions, % FL	105% for 85 minutes 110% for 60 minutes 125% for 10 minutes 150% for 1 minute		

1. The UPS will operate at full load, but the battery charge will either be reduced or Off (depending on input current).

2. The UPS will operate at full load, but UPS may source share with the batteries (depending on input current).

3. UPS will be in Battery mode

**Table 13 Liebert NXL UPS specifications (continued)**

Model Size	500kVA	625kVA	750kVA
<b>Physical Parameters and Standards, in (mm)</b>			
Width, With Static Bypass	111.6 (2835)	140.5 (3568)	
Width, without Static Bypass	111.6 (2835)	125 (3175)	
Depth	39.4 (1000)	39.4 (1000)	
Height	76.8 (1950)	76.8 (1950)	
Weight, Unpackaged, lb. (kg) approx., with Static Bypass (SMS)	10,310 (4676)	13,650 (6192)	
Weight, Unpackaged, lb. (kg) approx., with Static Bypass (1+N)	10,410 (4721)	13,800 (6260)	
Weight, Unpackaged, lb. (kg) approx., without Static Bypass (N+1)	10,210 (4631)	13,100 (5950)	
Max heat Dissipation, Full Load, BTU/hr	124,805	167,265	480V: 213,587 575V: 215,790 600V: 200,173
Cooling Air CFM	8113	15,760	15,760
Color	Black (ZP-7021)		
Front Door Opening (for serviceability)	More than 180°		
Degree of Protection for UPS Enclosure	IP 20 (with and without front door open)		
Minimum Clearance, Top, in (mm)	24 (610)		
Minimum Clearance, Back, in (mm)	0		
Minimum Clearance, Sides, in (mm)	0		
Location of Cable Entrance	Top or Bottom		
Standards and Conformities	UL 1778, 4th Ed. CSA 22.2 1073 FCC Part 15, Class A IEC62040-2, Level 4, Criteria A EN61000-4-3, Level 3, Criteria A EN61000-4-6, Level 4, Criteria A EN61000-2-2, Criteria A EN61000-4-4, Level 4, Criteria A ANSI C62.41, Category A3 & B3 ISTA Procedure 1H IBC 2012/CBC 2010 WEEE		
<b>Environmental Parameters</b>			
Storage Temperature Range, °F (°C)	-13 to 158 (-25 to 70)		
Operating Temperature Range, °F (°C)	32 to 104 (0 to 40) (UPS)		
Relative Humidity	95% or less Non-Condensing (Operating and Non-Operating)		
Maximum Altitude Above MSL, ft (m)	4920 (1500) (as per IEC 62040/3) - 1% Maximum kW derate / 328 rise between 4921-9842 (100m rise between 1500-3000m)		

1. Width dimensions are with side panels attached. Subtract 1.4" (35mm) for dimensions without side panels.
2. Depth dimensions include the front door and rear panel.

**Table 14 Current ratings—rectifier input**

UPS Rating		Voltage VAC	Nominal Current	Maximum Current
kVA	kW			
500	450	480	643	804
625	562.5	480	799	999
750	675	480	975	1219
750	675	575	815	1018
750	675	600	759	949

**Table 15 Current ratings—bypass input**

UPS Rating		Voltage VAC	Nominal Current
kVA	kW		
500	450	480	601
625	562.5	480	752
750	675	480	902
750	675	575	753
750	675	600	722

**Table 16 Current ratings—output**

UPS Rating		Voltage VAC	Nominal Current
kVA	kW		
500	450	480	601
625	562.5	480	752
750	675	480	902
750	675	575	753
750	675	600	722

**Table 17 Current ratings—battery**

UPS Rating		Voltage VAC	Nominal VDC	Maximum Battery Current at EOD
kVA	kW			
500	450	480	480	1241
625	562.5	480	480	1530
750	675	480	480	1845
750	675	575	480	1851
750	675	600	480	1845

**Notes on Tables**

1. Nominal input current (considered continuous) is based on full-rated output load. Maximum current includes nominal input current and maximum battery recharge current (considered noncontinuous). Continuous and noncontinuous current are defined in NEC 100.
2. Maximum input current is controlled by the current limit setting, which is adjustable. Values shown are for maximum current limit. If a smaller input feed breaker is used, the input current limit can be adjusted. Contact your Vertiv representative for more information.
3. The Rectifier Input Feed Breaker must be set to handle the @NXL transformer inrush of up to eight times the nominal current.
4. For breaker coordination while the module is overloaded, see the current-versus-time values on the overload curves in **Figures 42 and 43**.
5. Nominal battery voltage is shown at 2V/cell.

**Table 18 Recommended conduit and cable sizes**

<b>Rectifier Input</b>				
<b>UPS Rating</b>		<b>Voltage (VAC)</b>	<b>(# of conduits); size of conduits; # -size of phase cables per conduit; size of cable for ground per conduit</b>	
<b>kVA</b>	<b>kW</b>		<b>Copper Conductors</b>	<b>Aluminum Conductors</b>
500	450	480	(2) 3C, 3-750kcmil, #2/OAWG	(3) 2.5C 3-500kcmil, #4/OAWG
625	562.5	480	(3) 3.5C 3-600kcmil, #4/OAWG	(4) 3.0C 3-700kcmil, 350kcmil
750	675	480	(3) 3.5C, 3-750kcmil, #4/OAWG	(4) 3.0C 3-700kcmil, 350kcmil
750	675	575	(3) 3.0C, 3-600kcmil, #3/OAWG	(4) 2.5C 3-500kcmil, 250kcmil
750	675	600	(3) 3.5C, 3-600kcmil, #4/OAWG	(3) 2.5C 3-600kcmil, #4/OAWG
<b>Bypass Input</b>				
<b>UPS Rating</b>		<b>Voltage (VAC)</b>	<b>(# of conduits); size of conduits; # -size of phase cables per conduit; # -size of neutral cables per conduit; size of cable for ground per conduit</b>	
<b>kVA</b>	<b>kW</b>		<b>Copper Conductors</b>	<b>Aluminum Conductors</b>
500	450	480	(3) 4C, 3-500kcmil, 2-250kcmil, #1/OAWG	(3) 3.0C 3-600kcmil, 2-400kcmil, #3/OAWG
625	562.5	480	(4) 3.5C 3-500kcmil, 2-250kcmil, #2/OAWG	(4) 3.0C 3-500kcmil, 2-500kcmil, #4/OAWG
750	675	480	(3) 3.5C, 3-600kcmil, 2-500kcmil, #2/OAWG	(4) 3.0C 3-500kcmil, 2-500kcmil, #4/OAWG
750	675	575	(4) 4C, 3-500kcmil, 2-250kcmil, #2/OAWG	(4) 3.0C 3-500kcmil, 2-350kcmil, #3/OAWG
750	675	600	(4) 4C, 3-500kcmil, 2-250kcmil, #2/OAWG	(3) 3.5C 3-750kcmil, 2-500kcmil, #3/OAWG
<b>Output</b>				
<b>UPS Rating</b>		<b>Voltage (VAC)</b>	<b>(# of conduits); size of conduits; # -size of phase cables per conduit; # -size of neutral cables per conduit; size of cable for ground per conduit</b>	
<b>kVA</b>	<b>kW</b>		<b>Copper Conductors</b>	<b>Aluminum Conductors</b>
500	450	480	(3) 4C, 3-500kcmil, 2-250kcmil, #1/OAWG	(3) 3.0C 3-600kcmil, 2-400kcmil, #3/OAWG
625	562.5	480	(4) 3.5C 3-500kcmil, 2-250kcmil, #2/OAWG	(4) 3.0C 3-500kcmil, 2-500kcmil, #4/OAWG
750	675	480	(3) 3.5C, 3-600kcmil, 2-500kcmil, #2/OAWG	(4) 3.0C 3-500kcmil, 2-500kcmil, #4/OAWG
750	675	575	(4) 4C, 3-500kcmil, 2-250kcmil, #2/OAWG	(4) 3.0C 3-500kcmil, 2-350kcmil, #3/OAWG
750	675	600	(4) 4C, 3-500kcmil, 2-250kcmil, #2/OAWG	(3) 3.5C 3-750kcmil, 2-500kcmil, #3/OAWG
<b>Battery</b>				
<b>UPS Rating</b>		<b>(# of conduits); size of conduits; # -size of phase cables per conduit; size of cable for ground per conduit</b>		
<b>kVA</b>	<b>kW</b>	<b>Copper Conductors</b>	<b>Aluminum Conductors</b>	
500	450	(4) 3C, 2-600kcmil, #4/OAWG	(4) 2.5C 2-700kcmil, 350kcmil	
625	562.5	(4) 3C 2-600kcmil, #4/OAWG	(6) 2.5C 2-600kcmil, 400kcmil	
750	675	(5) 3C, 2-600kcmil, 250kcmil	(6) 2.5C 2-600kcmil, 400kcmil	
<b>Bonding</b>				
<b>UPS Rating</b>		<b>Main Bonding Jumper/Grounding Electrode Conductor</b>		
<b>kVA</b>	<b>kW</b>	<b>Copper Conductors</b>	<b>Aluminum Conductors</b>	
500	450	(1) #4/OAWG/ (1) #4/OAWG	(1) #4/OAWG/ (1) #4/OAWG	
625	562.5	(1) 250kcmil/ (1) 250kcmil	(1) 250kcmil/ (1) 250kcmil	
750	675	(1) 250kcmil/ (1) 250kcmil	(1) 250kcmil/ (1) 250kcmil	

1. Recommended cable sizes are 167°F (75°C) (THW) wire at 86°F (30°C) ambient. Unless otherwise noted, use copper or aluminum conductors suitable for at least 75°C.
2. For continuous operations not at 86°F (30°C), recommend that the site planner choose the appropriate cable type based on the particular installation requirements.
3. Conduit size is based on FMC type conduit with two neutral conductors rated at 200% of phase.



Figure 42 Inverter overload data

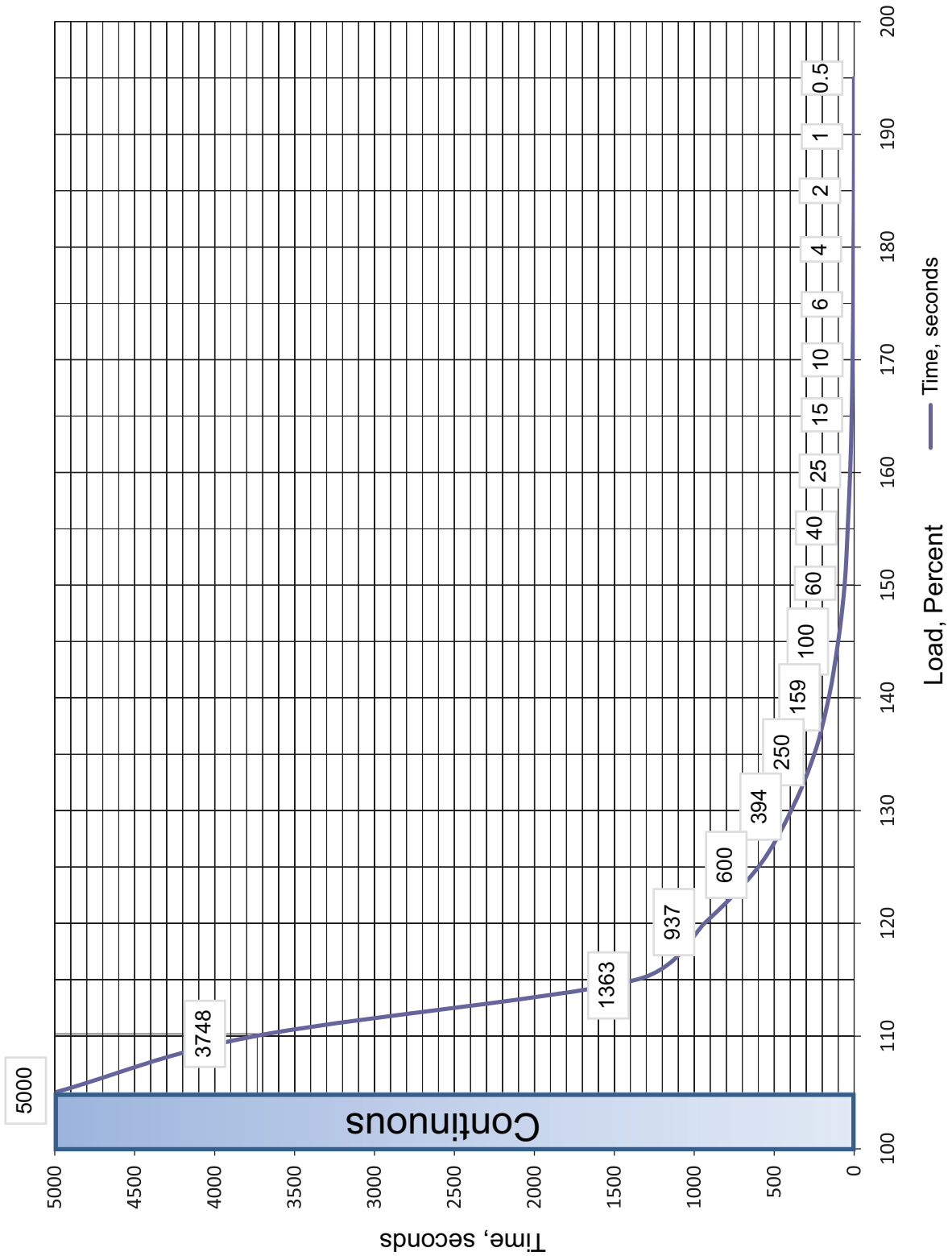
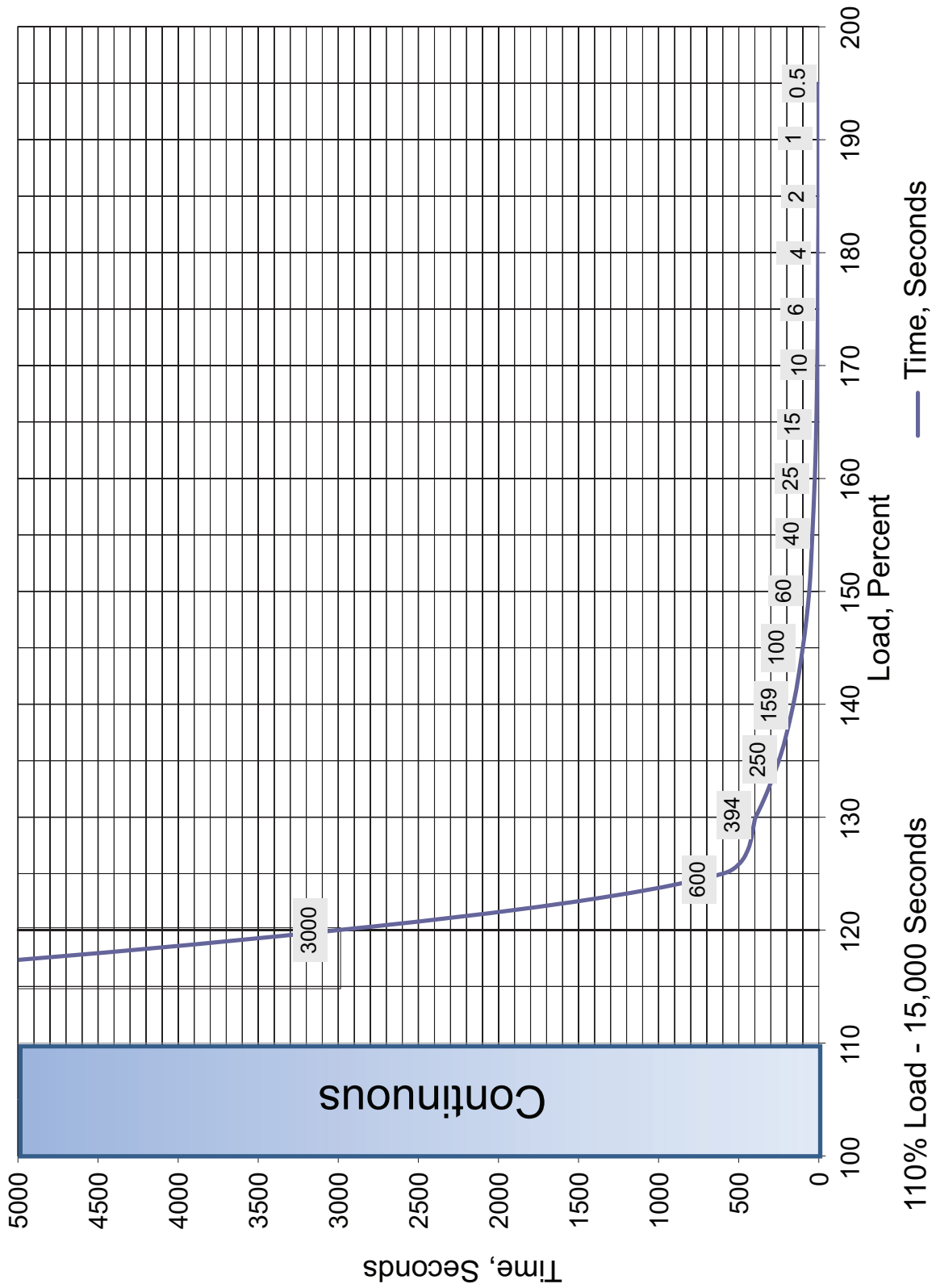


Figure 43 Bypass overload data



**Table 19 Recommended lug sizes**

Cable Size	T&B Copper One Hole	T&B Copper Two Hole	T&B Aluminum One Hole	T&B Aluminum Two Hole
#8 AWG	54930BE	54850BE	60104-TB	—
#6 AWG	54905BE	256-30695-868	60109-TB	—
#4 AWG	54906BE	256-30695-733	60114-TB	—
#2-3 AWG	54942BE	54811BE	60120	—
#1 AWG	54947BE	54857BE	60126	—
#1/0 AWG	54950BE	256-30695-593	60132	—
#2/0 AWG	54951BE	54862BE	60138	60238
#3/0 AWG	54965BE	54864BE	60144	60244
#4/0 AWG	54970BE	54866BE	60150	60250
250kcmil	54913BE	54868BE	60156	60256
300kcmil	54914BE	54870BE	60162	60262
350kcmil	54915BE	54872BE	60165	60267
400kcmil	54916BE	54874BE	60168	60269
500kcmil	54918BE	54876BE	60171	60273
600kcmil	54920BE	54878BE	60176	60275
750kcmil	54922BE	54880BE	60178	60277

**Table 20 Recommended torque values**

Grade 5 Steel: Unified Thread System Torque, lbf.*in.				Class 8.8 Steel: Metric Thread System Torque, Nm*			
Fastener Finish ⇒		Plain Steel	Zinc Plating	Fastener Finish ⇒		Plain Steel	Zinc Plating
Size	Threads/ Inch, Tpi	No Washer/ Flat Washer	No Washer/ Flat Washer	Size	Thread Pitch, Tp	No Washer/ Flat Washer	No Washer/ Flat Washer
1/4	20	101	91	M5	0.8	6.1	5.5
	28	116	104		0.5	6.9	6.2
5/16	18	209	188	M6	1	10	9
	24	231	208		0.75	11	10
3/8	16	370	333	M8	1.25	25	23
	24	420	378		1	27	24
7/16	14	593	534	M10	1.5	50	45
	20	662	596		1.25	53	47
1/2	13	904	814	M12	1.75	87	78
	20	1,020	918		1.25	95	86
9/16	12	1,305	1,175	M14	2	139	125
	18	1,456	1,310		1.5	151	136

## NOTES





## **TECHNICAL SUPPORT / SERVICE**

### **Web Site**

[www.vertivco.com](http://www.vertivco.com)

### **Monitoring**

[liebert.monitoring@vertivco.com](mailto:liebert.monitoring@vertivco.com)

800-222-5877

Outside North America: +00800 1155 4499

### **Three-Phase UPS & Power Systems**

800-543-2378

Outside North America: 614-841-6598

## **LOCATIONS**

### **United States**

1050 Dearborn Drive

P.O. Box 29186

Columbus, OH 43229

### **Europe**

Via Leonardo Da Vinci 8

Zona Industriale Tognana

35028 Piove Di Sacco (PD) Italy

+39 049 9719 111

Fax: +39 049 5841 257

### **Asia**

29/F, The Orient Square Building

F. Ortigas Jr. Road, Ortigas Center

Pasig City 1605

Philippines

+63 2 687 6615

Fax: +63 2 730 9572

---



**VertivCo.com | Vertiv Headquarters, 1050 Dearborn Drive, Columbus, OH, 43085, USA**

© 2016 Vertiv Co. All rights reserved. Vertiv and the Vertiv logo are trademarks or registered trademarks of Vertiv Co. All other names and logos referred to are trade names, trademarks or registered trademarks of their respective owners. While every precaution has been taken to ensure accuracy and completeness herein, Vertiv Co. assumes no responsibility, and disclaims all liability, for damages resulting from use of this information or for any errors or omissions. Specifications are subject to change without notice.

SL-25434\_REV16\_12-16